

Front Wheelhouse Replacement

Removal Procedure

Caution: Foam sound deadeners must be removed from areas within 152.4 mm (6 in) of where flame is to be used for body repairs. When reinstalling foam sound deadeners, avoid inhaling fumes as bodily injury may result.

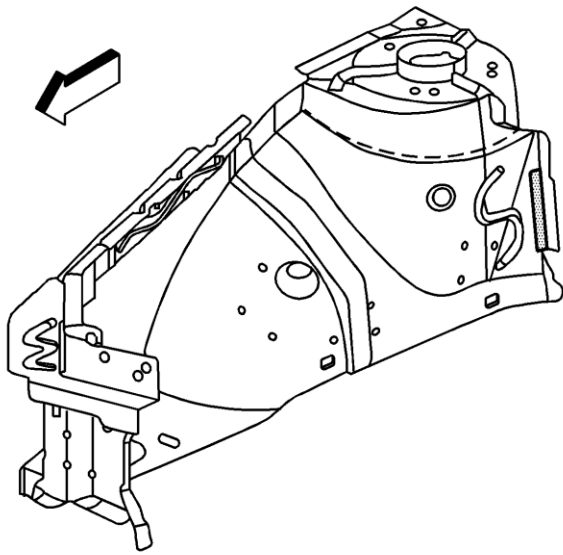
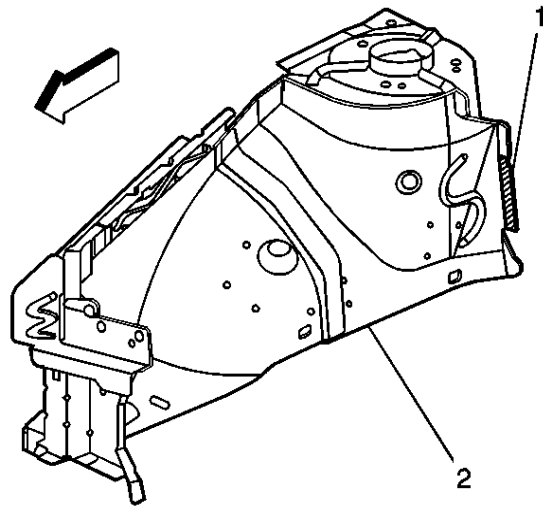

Important: Both the driver-side and passenger-side front wheelhouses are available as complete assemblies with the strut tower attached to the wheelhouse. The strut mounting holes are pre-punched in the service part, which also includes all necessary component stud mounts. When replacing a wheelhouse, carefully position the service assembly. Use 3-dimensional measuring equipment to properly locate the wheelhouse.



1. Remove all related panels and components.
2. Visually inspect and restore as much of the damage as possible to factory specifications.
3. Remove all sealers and anti-corrosion materials, as necessary.
4. Place a piece of 25 mm (1 in) wide masking tape (1) on the forward contour of the wheelhouse at the flange, where it attaches to the cowl panel.

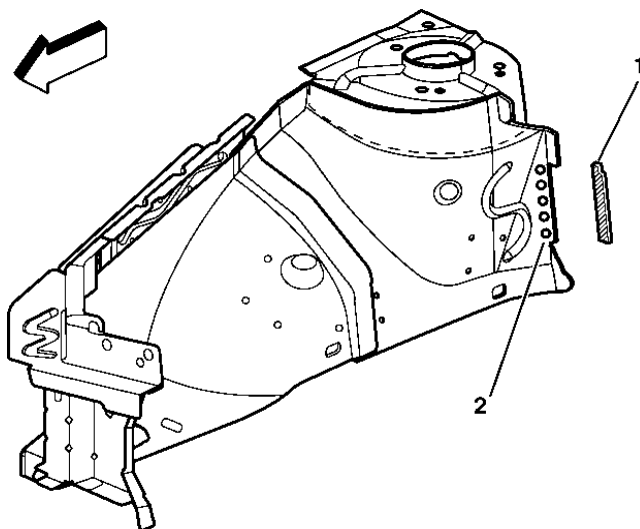

5. Cut the wheelhouse along the forward edge of the masking tape to leave a 25 mm (1 in) tab extending forward from the cowl panel (1).
6. Locate, mark and drill out factory welds, which attach the wheelhouse assembly to the following areas (2):
 - The upper rail inner panel

- The cowl panel
- The radiator support
- The lower front rails

10. Remove the damaged wheelhouse assembly.

Installation Procedure

1. Clean and prepare surfaces to be welded.

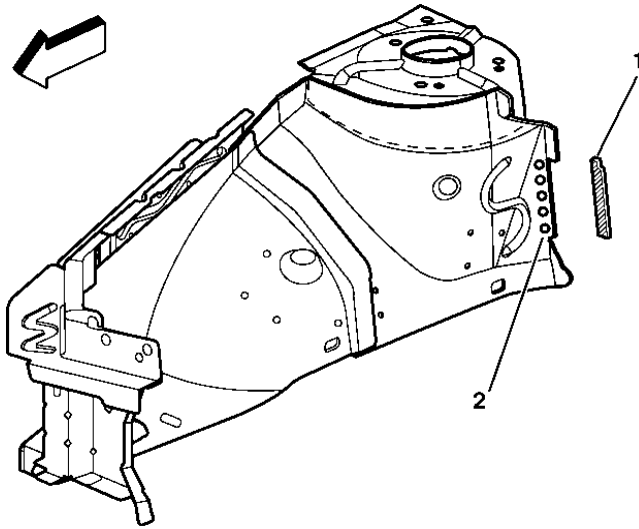

2. Cut the flange off the service part that is normally welded to the cowl panel (1).
3. Drill 8 mm (5/16 in) holes for plug welding in the locations noted from the original assembly.
4. Drill holes for plug welding every 40 mm (1½ in) along the cut edge to be attached to the tab remaining from the original assembly (2).
5. Inspect the position of the wheelhouse assembly, use 3-dimensional measuring equipment.
6. Plug weld accordingly.
7. Clean and prepare all welded surfaces.
8. Prime with 2-part catalyzed primer.
9. Apply the following as necessary:
 - Sealers
 - Sound deadeners
 - Anti-corrosion materials

12. Install all related panels and components.