

Rail Sectioning Rear Side Underbody

Removal Procedure

Caution: Refer to [Approved Equipment for Collision Repair Caution](#) in Cautions and Notices.

Caution: Sectioning should be performed only in the recommended areas. Failure to do so may compromise the structural integrity of the vehicle and cause personal injury if the vehicle is in a collision.

1. Disable the SIR system. Refer to [SIR Disabling and Enabling](#) .
2. Disconnect the negative battery cable. Refer to [Battery Negative Cable Disconnection and Connection](#) .
3. Remove all of the related panels and the components.
4. Remove the sealers and anti-corrosion materials from the repair area, as necessary. Refer to [Anti-Corrosion Treatment and Repair](#) .
5. Repair as much of the damage as possible. Refer to [Dimensions - Body](#) .

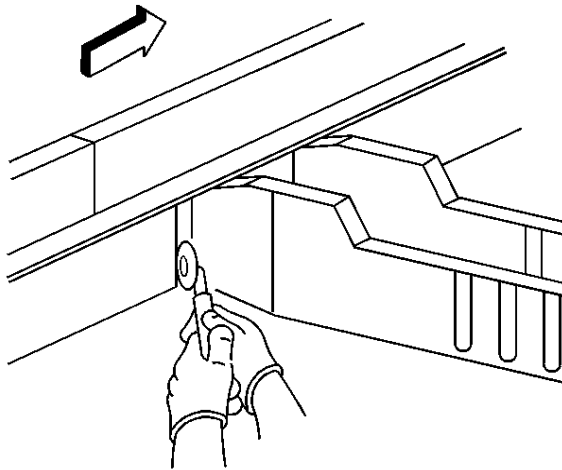

6. Cut the rear rail along the rearward flange of the crossbar.
7. Continue this cut around the rear rail.
8. Drill out factory welds to rear floor.
9. Remove the damaged component from the vehicle.

Installation Procedure

1. Use the original parts as a guide, mark a line on the service rail 35 mm (1-5/16 in) forward of the cut made to the original part. This will provide an overlap for welding the service section.

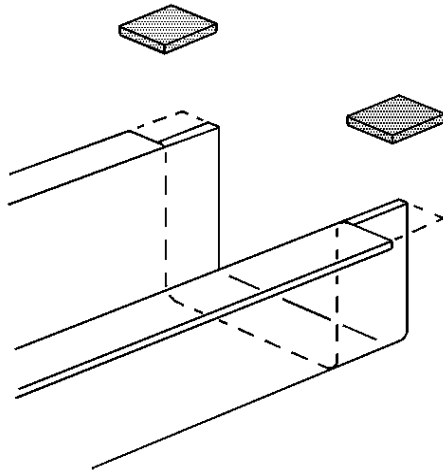

2. Cut the service rail along the marked lines and discard the unused section.
3. Cut and remove approximately 35 mm (1-5/16 in) of the flanges on the service rail.
4. Cut a 5 mm (1/4 in) gap approximately 35 mm (1-5/16 in) along the corners of the service rail to create tabs.

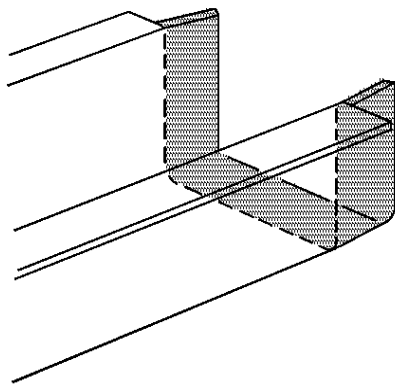

5. Step the tabs inward to allow the service rail to fit inside the original rail.

6. Position the modified service rail inside the original rail, allow 35 mm (1-5/16 in) of overlap.

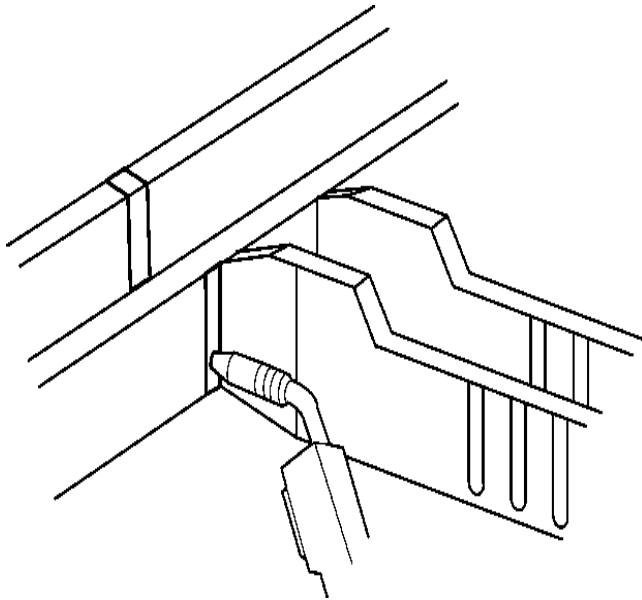

7. Check the position of the service rear rail section using 3-dimensional measuring equipment and tack weld in 3 locations along all 3 sides of the rail.
8. Drill two 8 mm (5/16 in) holes for plug welding in each of the 3 sides of the rail approximately 30 mm (1-3/16 in) from the sectioning joint.
9. Plug weld at each 8 mm (5/16 in) plug weld hole location.
10. Stitch weld along the entire sectioning joint. Make welds along the seam with 25 mm (1 in) gaps between. Weld the gaps. Replace factory welds, as necessary.
11. Clean and prepare the welded surfaces.
12. Install all of the related panels and components.
13. Apply the sealers and anti-corrosion materials to the repair area, as necessary. Refer to [Anti-Corrosion Treatment and Repair](#) .
14. Paint the repaired area. Refer to [Anti-Corrosion Treatment and Repair](#) .
15. Enable the SIR system. Refer to [SIR Disabling and Enabling](#) .
16. Connect the negative battery cable. Refer to [Battery Negative Cable Disconnection and Connection](#) .