

Buick Rendezvous

Radiator Upper Support Replacement

Removal Procedure

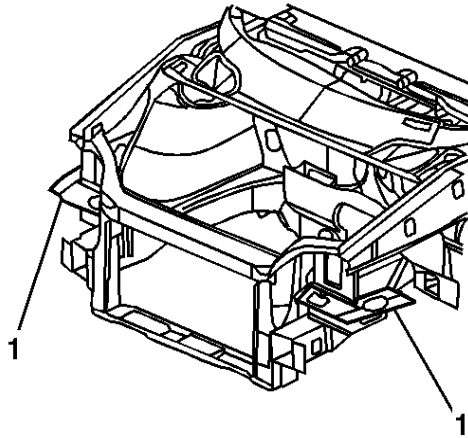

1. Remove all related panels and components including front fascia support right and left (1).
2. Restore as much of the damage as possible to factory specifications.
3. Note the location and remove the following as necessary:
 - Sealers
 - Sound deadeners
 - Anti-corrosion materials

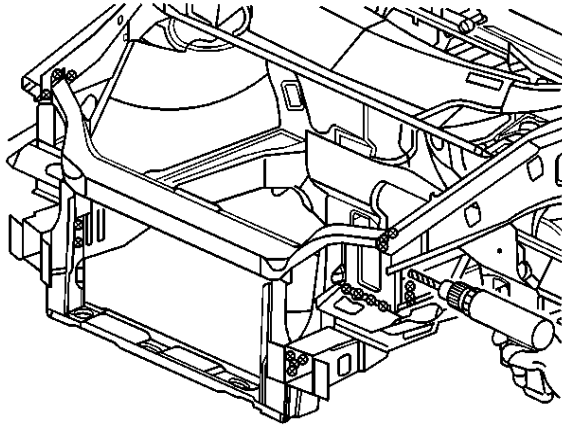

Important: Do not damage any inner panels or reinforcements.

4. Locate and drill out all factory welds. Note the number and location of welds for installation of the radiator support assembly.

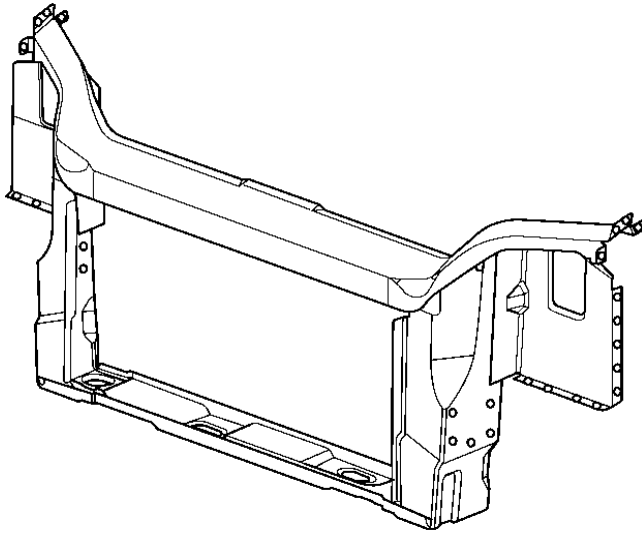

5. Remove the damaged Radiator Support Assembly.

Installation Procedure

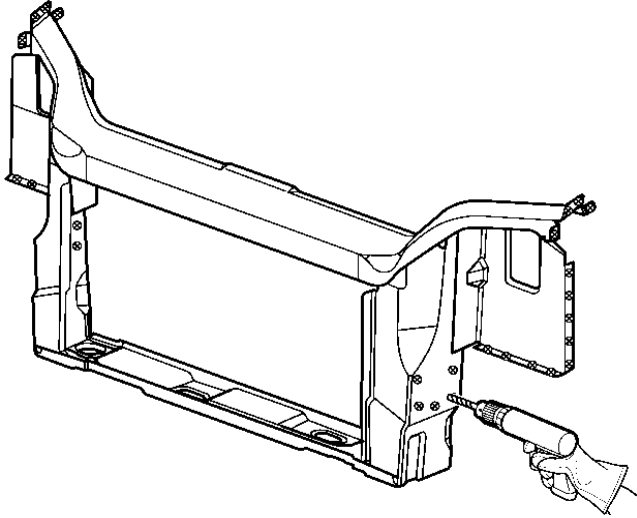

Important: In any area damaged beyond recognition, space plug weld holes every 40 mm (1 ½ in) apart.

1. Drill 8 mm (5/16) plug weld holes as necessary in locations noted from the original panel.
2. Prepare all attachment surfaces as necessary.
3. Apply GM-approved Weld-Thru Coating or equivalent to all mating surfaces. Refer to [Anti-Corrosion Treatment and Repair](#) .

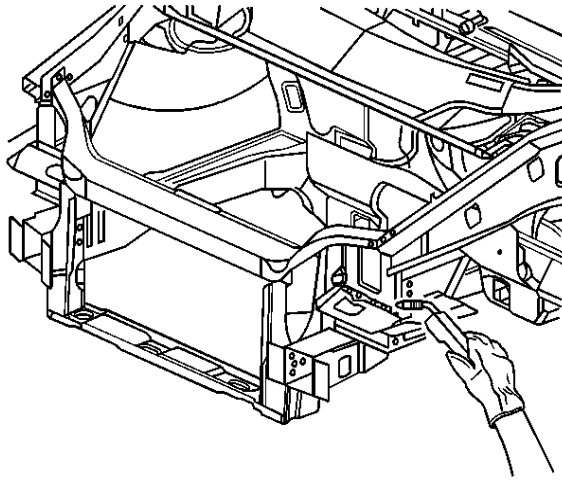

4. Position the Radiator Support Assembly.
5. Plug weld accordingly.
6. Clean and prepare all welded surfaces.

Important: Prior to refinishing, refer to publication GM 4901M-D-2000 GM Approved Refinish Materials for recommended products. Do not combine paint systems. Refer to paint manufacturer's recommendations.

7. Apply the following as necessary:
 - an approved anti-corrosion primer
 - sound deadening materials
 - sealers and refinish materials

10. Install all related panels and components.