

Pillar Replacement – Center Reinforcement

Removal Procedure

CAUTION: Refer to Glass and Sheet Metal Handling in Cautions and Notices.

1. Disable the SIR system. Refer to Disabling the SIR System in Cautions and Notices.
2. Disconnect the negative battery cable. Refer to Battery Negative Cable Disconnect/Connect Procedure in Cautions and Notices.

CAUTION: Sectioning should be performed only in the recommended areas. Failure to do so may compromise the structural integrity of the vehicle and cause personal injury if the vehicle is in a collision.

3. Remove all related panels and components.
4. Restore as much of the damage as possible.
5. Remove the sealers and anti-corrosion materials from the repair area, as necessary. Refer to Anti -Corrosion Treatment and Repair in Cautions and Notices.
6. Note structural adhesive locations.

IMPORTANT: Do not damage any inner panels or reinforcements.

7. Measure down (a) 220 mm (8-5/8 in.) from the edge of the door opening. Create a cut line.

8. Cut the panel where sectioning is to be performed.

IMPORTANT: Note the number and location of the factory welds for installation of the center pillar.

9. Locate, mark, and drill out all the necessary factory welds.
10. Remove the damaged reinforcement.

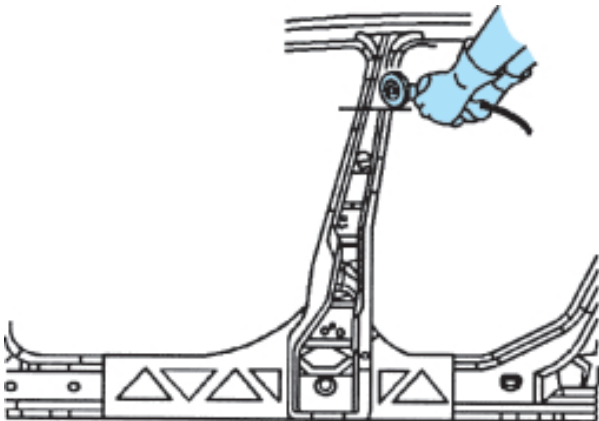
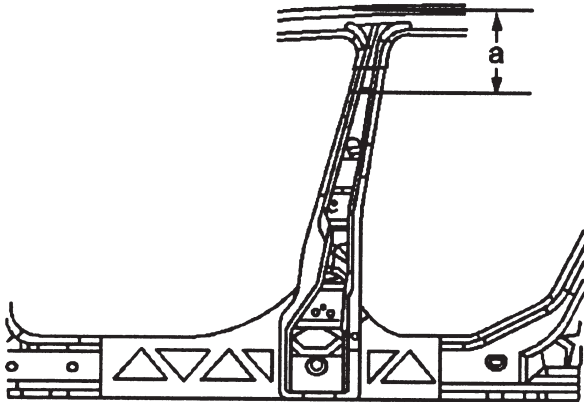
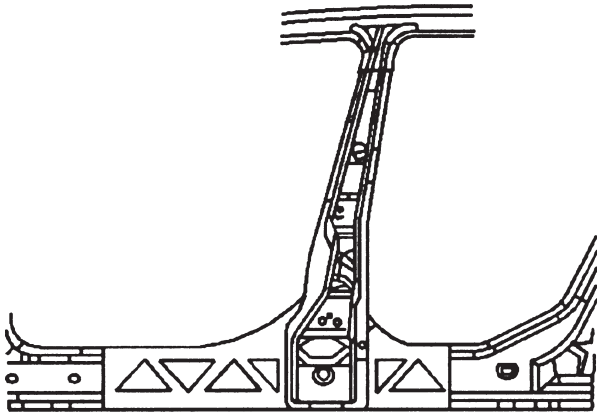

Installation Procedure

1. Measure the service part 30 mm (1-3/16 in.) longer than the original reinforcement to allow for an overlap.
2. Cut the service part at this sectioning location.

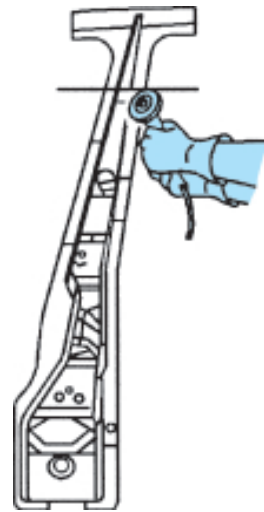

3. Cut the service part in the corners as shown and step the tabs inward to allow the service part to fit under the original reinforcement.
4. Drill 8 mm (5/16 in.) plug weld holes along the sectioning cut on the original reinforcement. Locate these holes 13 mm (1/2 in.) from the edge and spaced 40 mm (1-1/2 in.) apart.

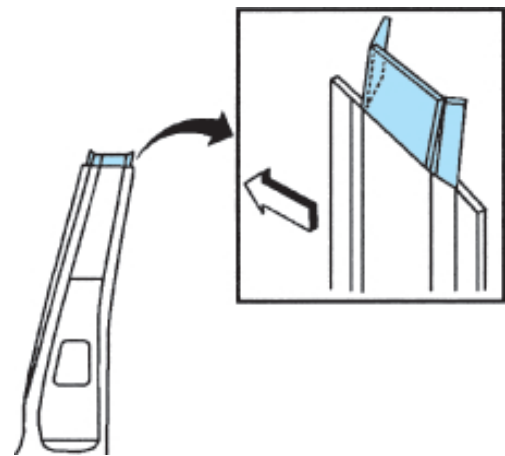

IMPORTANT: In the area damaged beyond recognition, place plug weld holes 40 mm (1-1/2 in.) apart.

5. Drill 8 mm (5/16 in.) plug weld holes in the service reinforcement as necessary in the locations noted from the original panel.
6. Prepare all attachment surfaces as necessary.
7. Apply weld-thru primer to all bare metal surfaces.
8. Apply structural adhesive such as Lord 108 to locations noted in the Removal Procedure.

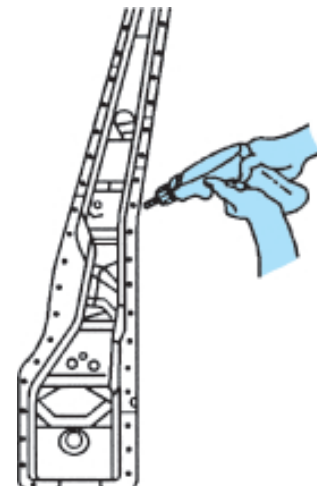

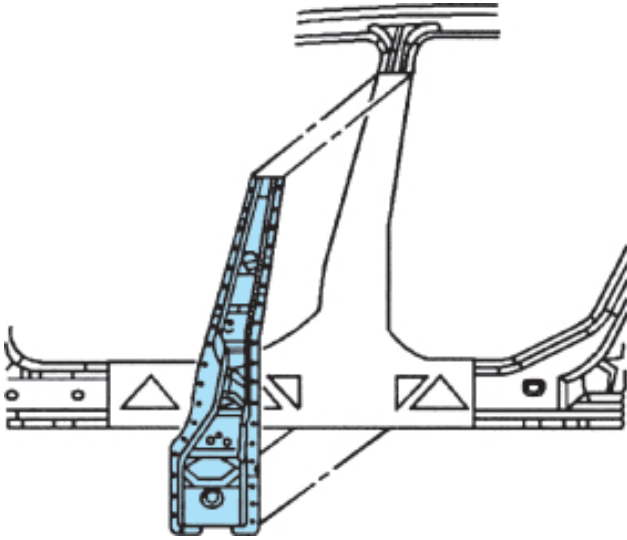

9. Align the service part on the vehicle using 3-dimensional measuring equipment.
10. Plug weld accordingly.
11. To create a solid weld with minimum heat distortion, make 25 mm (1 in.) stitch welds along the seam with 25 mm (1 in.) gaps between them. Go back and complete the stitch weld.
12. Clean and prepare all of the welded surfaces.
13. Apply the sealers and anti-corrosion materials to the repair area, as necessary. Refer to Anti-Corrosion Treatment and Repair in Cautions and Notices.
14. Paint the repaired area. Refer to Basecoat/Clearcoat Paint Systems in Cautions and Notices.
15. Install all of the related panels and components.
16. Connect the negative battery cable. Refer to Battery Negative Cable Disconnect/Connect Procedure in Cautions and Notices.
17. Enable the SIR system. Refer to Enabling the SIR System in Cautions and Notices.