

Pillar Sectioning – Center Inner

Removal Procedure

CAUTION: Refer to Glass and Sheet Metal Handling in Cautions and Notices.

CAUTION: Sectioning should be performed only in the recommended areas. Failure to do so may compromise the structural integrity of the vehicle and cause personal injury if the vehicle is in a collision. Note the center pillar reinforcement must be removed from the vehicle to perform this operation.

1. Remove all related panels and components.
2. Disable the SIR system. Refer to Disabling the SIR System in Cautions and Notices.
3. Disconnect the negative battery cable. Refer to Battery Negative Cable Disconnect/Connect Procedure in Cautions and Notices.
4. Restore as much of the damage as possible.
5. Remove the sealers and anti-corrosion materials from the repair area, as necessary. Refer to Anti-Corrosion Treatment and Repair in Cautions and Notices.
6. Note structural adhesive locations.
7. In the inner upper center pillar area, locate the “T” shaped opening on the inside of the pillar. Measure down (a) 100 mm (4 in.) from the bottom of the opening. This is your sectioning location.
8. In the inner rocker panel area, select the triangle shaped openings in the front and rear of the pillar areas to be replaced, as shown. These are your lower section locations.

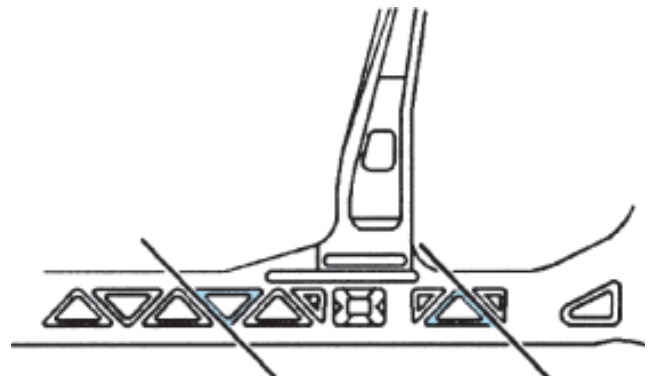
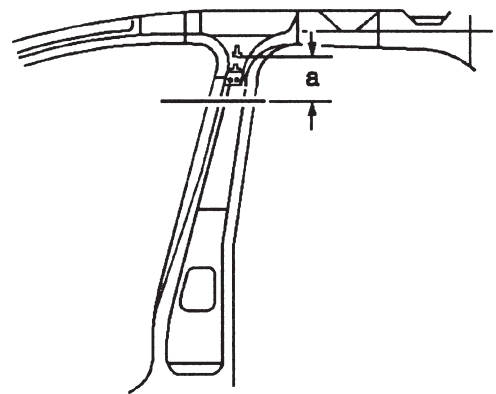
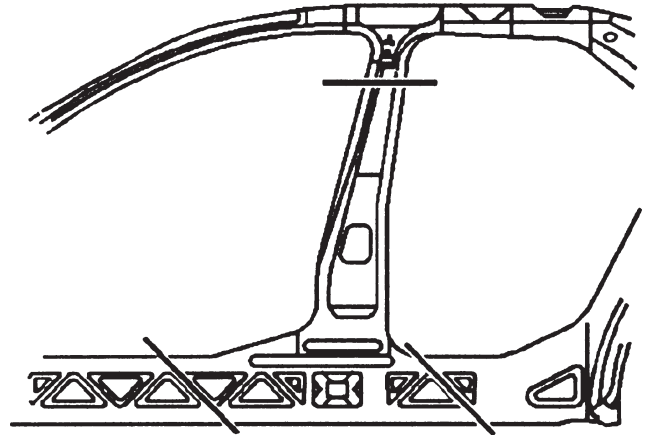

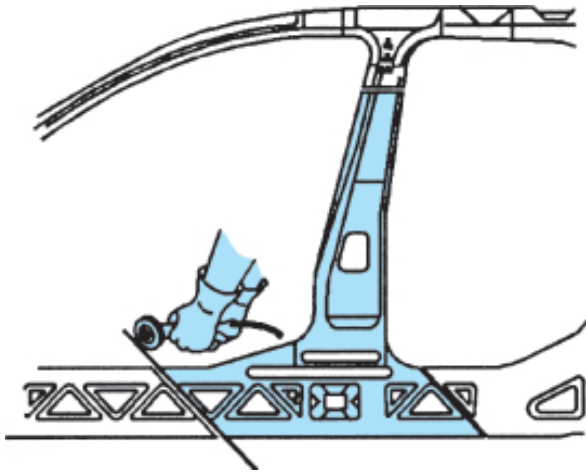

IMPORTANT: Do not damage any inner reinforcements. Cut the panel where sectioning is to be performed.

9. Locate and drill out all factory welds. Note the number and location of the welds for installation of the service part.

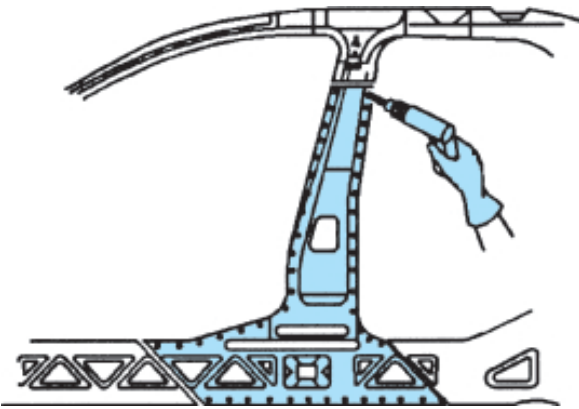

10. Remove the damaged center pillar.

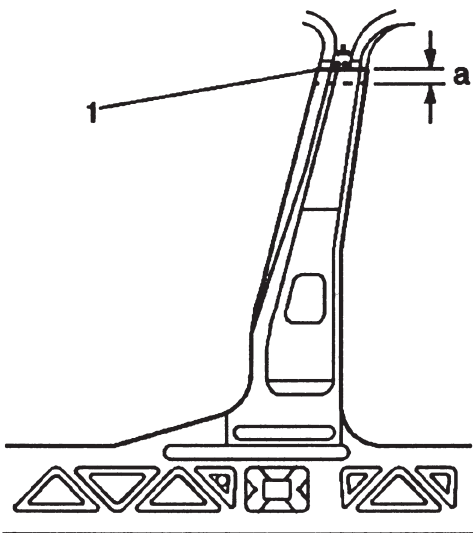

Installation Procedure

1. Cut the replacement service part in the pillar area (1) to allow for a (a) 25 mm (1 in.) overlap of the original section cut.

2. On the pillar area of the service part notch the weld flange areas as shown.

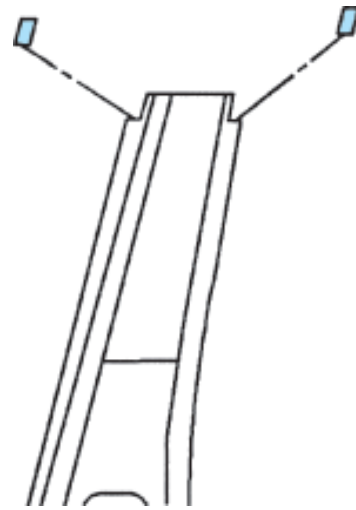

3. Cut the service part in the corners as shown and step the tabs inward to allow the service part to fit under the original reinforcement.

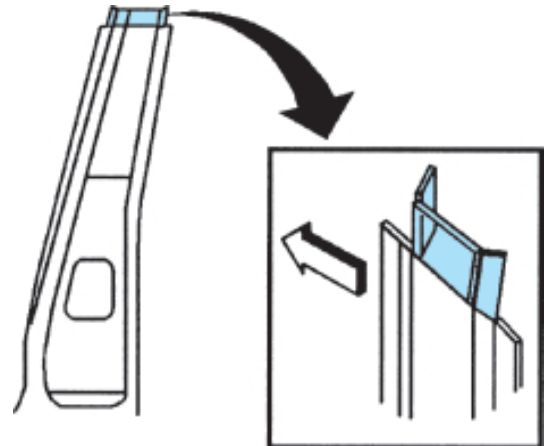

4. Cut the replacement service part vertically in the rocker panel areas to allow for a full overlap and notch as shown.
5. Drill 8 mm (5/16 in.) plug weld holes along the sectioning cut on the original reinforcement. Locate these holes 13 mm (1/2 in.) from the edge and spaced 40 mm (1-1/2 in.) apart.

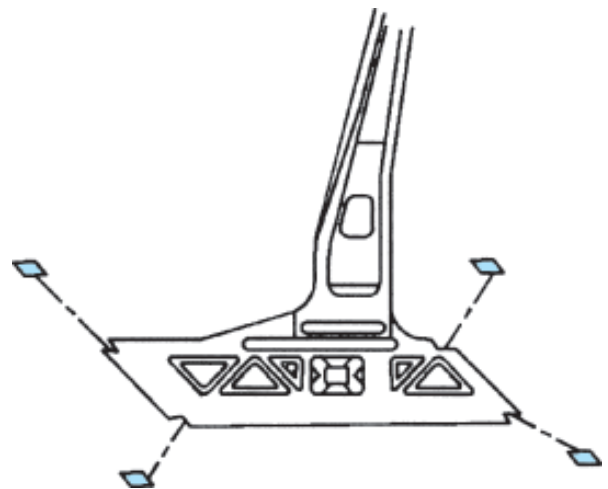

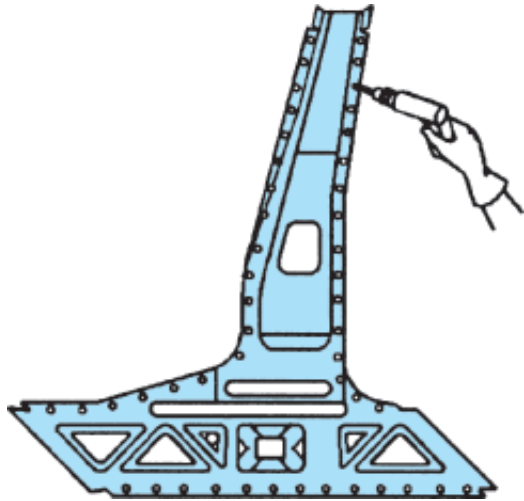

6. Drill 8 mm (5/16 in.) plug weld holes in the center pillar as necessary in the locations noted from the original panel.
7. Prepare all attachment surfaces as necessary.
8. Apply weld-thru primer to all bare metal surfaces.

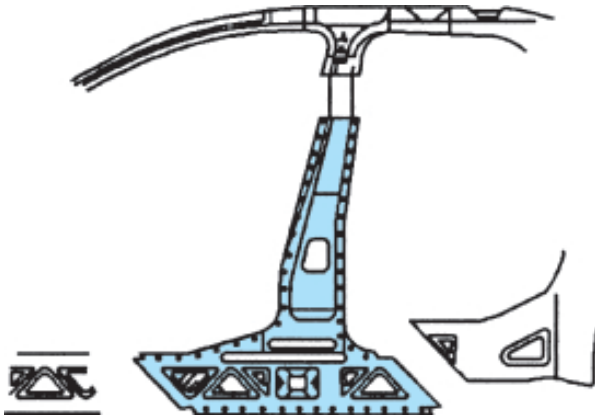

9. Align the service part on the vehicle using 3-dimensional measuring equipment.

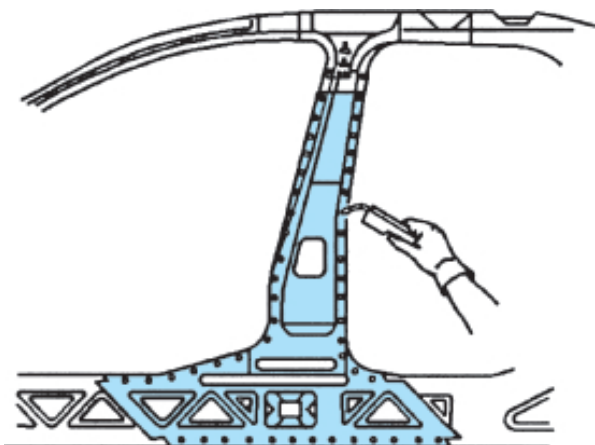

10. Plug weld accordingly.
11. To create a solid weld with minimum heat distortion, make 25 mm (1 in.) stitch welds along the seam with 25 mm (1 in.) gaps between them. Go back and complete the stitch weld.
12. Clean and prepare all of the welded surfaces.
13. Apply the sealers and anti-corrosion materials to the repair area, as necessary. Refer to Anti-Corrosion Treatment and Repair in Cautions and Notices.
14. Paint the repaired area. Refer to Basecoat/Clearcoat Paint Systems in Cautions and Notices.
15. Install all of the related panels and components.
16. Connect the negative battery cable. Refer to Battery Negative Cable Disconnect/Connect Procedure in Cautions and Notices.
17. Enable the SIR system. Refer to Enabling the SIR System in Cautions and Notices.