

Roof Outer Replacement

Removal Procedure

CAUTION: Refer to Glass and Sheet Metal Handling in Cautions and Notices. The roof panel is attached to the steel roof structure with beads of adhesive on the sides and spot-welds on the side rail, windshield and back-glass flanges. Replacement of the roof panel can be performed using conventional procedures, however, the windshield and back glass must be removed. Factory roof panel is attached with spot welds on the side rails, the service part will use adhesive only on both side rails

IMPORTANT: Use care when cutting to protect adjacent panels. Cut inboard of the roof structure.

1. Disable the SIR system. Refer to Disabling the SIR System in Cautions and Notices.
2. Disconnect the negative battery cable. Refer to Battery Negative Cable Disconnect/Connect Procedure in Cautions and Notices.
3. Remove all related panels and components.
4. Visually inspect and restore as much of the damage as possible.
5. Remove the sealers and anti-corrosion materials from the repair area, as necessary. Refer to Anti-Corrosion Treatment and Repair in Cautions and Notices.
6. Locate and mark all factory welds.
7. Drill all factory welds. Note the number and location of welds for installation of the service assembly.
8. Cut the adhesive with an appropriate tool after removing the panel.
9. Remove the remaining portion of the original panel.

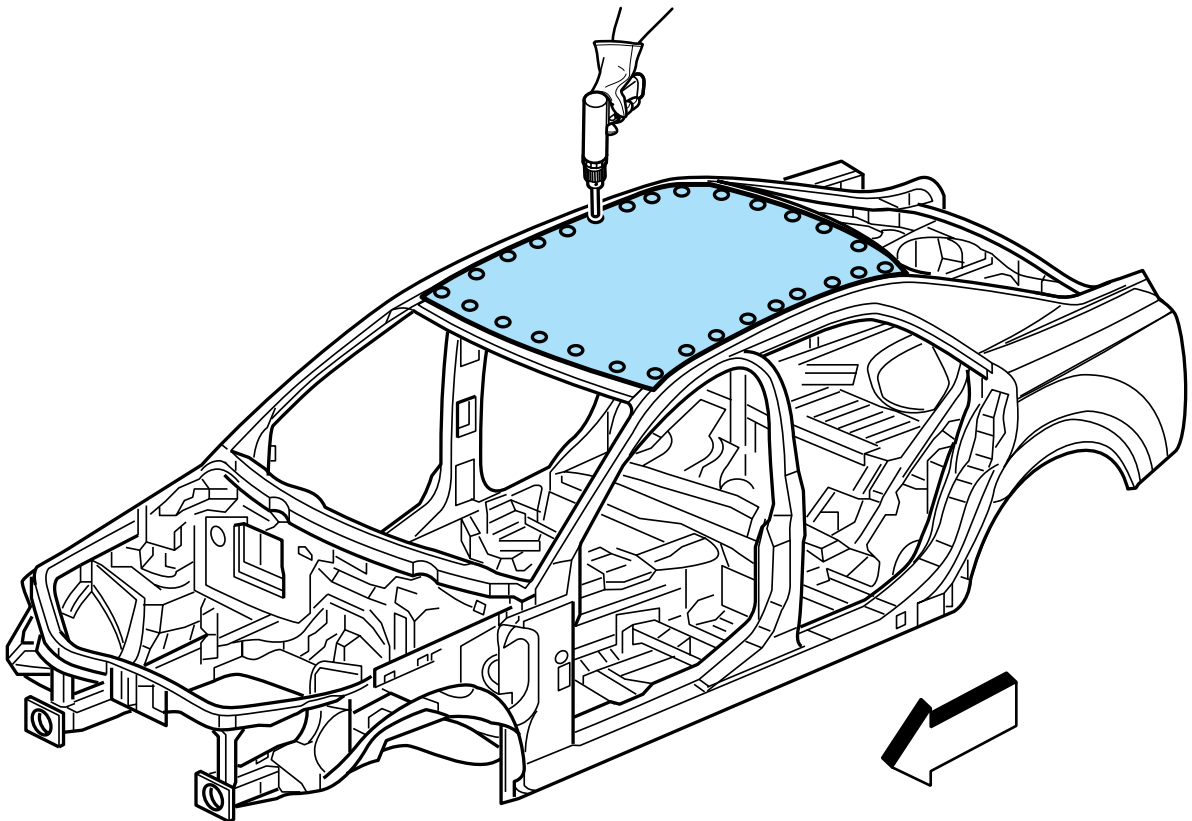

Installation Procedure

1. Clean and prepare the attaching surfaces for welding.
2. Drill 8 mm (5/16 in.) for plug welding along the windshield and back glass edges of the service panel as noted from the original panel. Drill the holes for plug welding along the front and rear flanges every 40 mm (1-1/2 in.).
3. Position the service panel
4. Install the panel using 1-part windshield urethane on both side rails.
5. Check the fit.

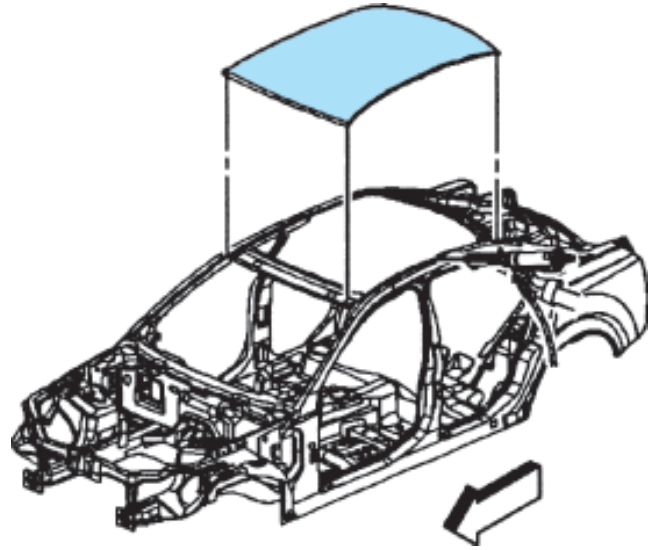

6. Plug weld accordingly
7. Prime with 2-part catalyzed primer.
8. Apply the sealers and anti-corrosion materials to the repair area, as necessary. Refer to Anti-Corrosion Treatment and Repair in Cautions and Notices.
9. Install all related panels and components.
10. Connect the negative battery cable. Refer to Battery Negative Cable Disconnect/Connect Procedure in Cautions and Notices.
11. Enable the SIR system. Refer to Enabling the SIR System in Cautions and Notices.

