

Front Wheelhouse Replacement

Removal Procedure

Caution: Refer to [Approved Equipment for Collision Repair Caution](#) in the Preface section.

1. Disable the SIR system. Refer to [SIR Disabling and Enabling](#) .
2. Disconnect the negative battery cable. [Refer to Battery Negative Cable Disconnection and Connection](#) .

Important: The front wheelhouse service panel is serviced as a complete assembly, which includes the upper front strut mounting surface. The upper strut mounting surface is a dimensionally critical area. Use 3-dimensional measuring equipment to locate the front wheelhouse assembly.

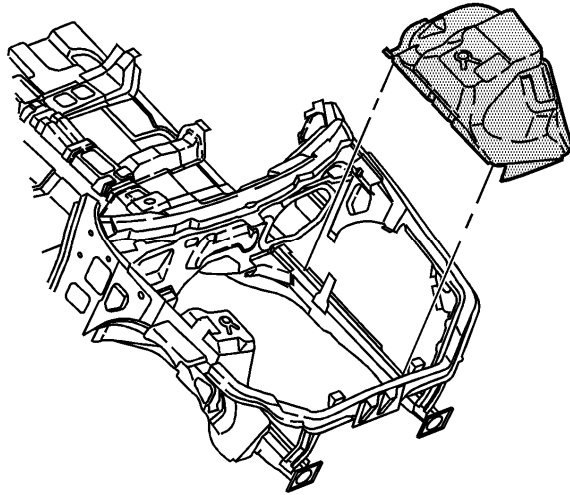

3. Remove the sealers and anti-corrosion materials from the repair area, as necessary. Refer to [Anti-Corrosion Treatment and Repair](#) .
4. Repair as much of the damage as possible.

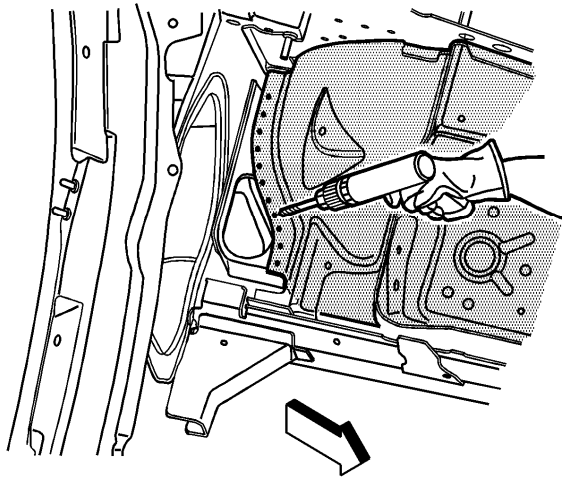

5. Locate, mark, and drill out all factory welds. Note the number and location of welds for installation of the service assembly.

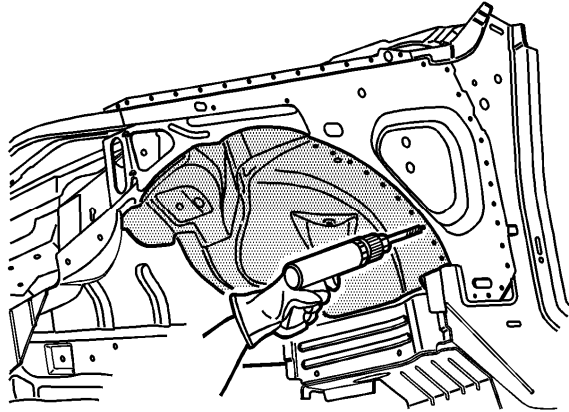

6. Drill from the outside of the wheelhouse to remove the spot welds that attach the wheelhouse to the frame rail.

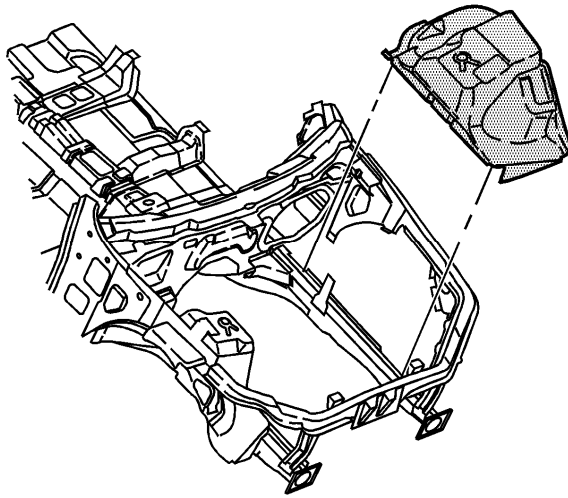

7. Remove the wheelhouse from the vehicle.

[Installation Procedure](#)

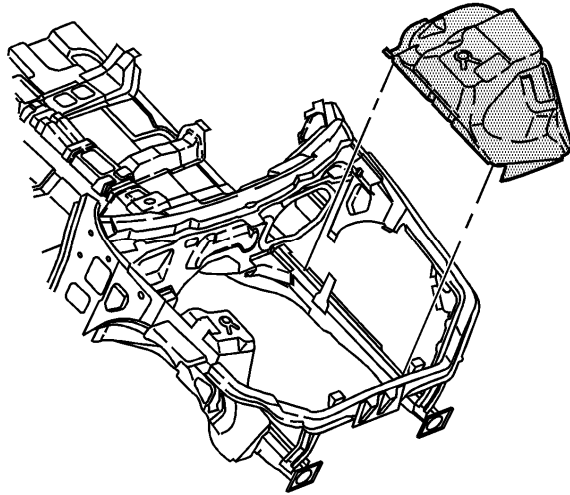

1. Prepare the mating surfaces as necessary.
2. Apply Weld-Thru Coating to all mating surfaces. Refer to [Anti-Corrosion Treatment and Repair](#)
3. Drill 8 mm (5/16 in) plug weld holes as necessary in the locations noted from the original assembly.

Important: If the location of the original plug weld holes can not be determined, or if structural weld-thru adhesive is present, space the plug weld holes every 40 mm (1½ in).

4. Position the wheelhouse on the vehicle. Verify proper fit using 3-dimensional measuring equipment.

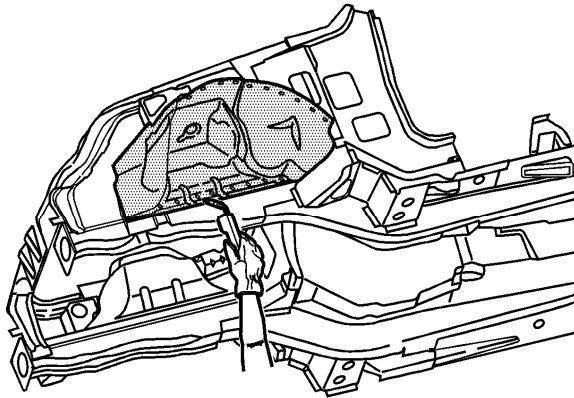

5. Measure frequently to ensure proper fit and alignment.

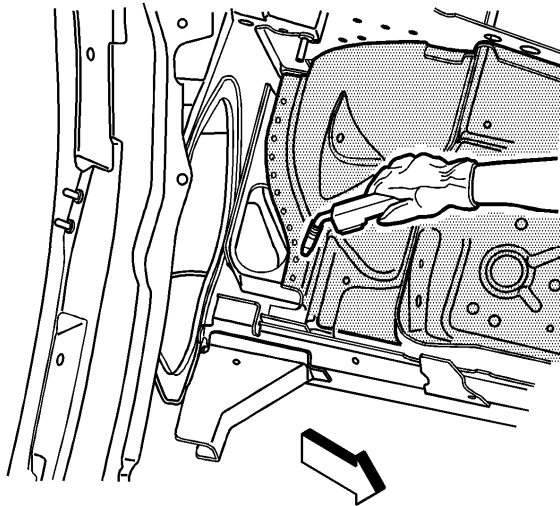

6. When the service assembly is correctly positioned, plug weld accordingly.
7. Clean and prepare all welded surfaces.
8. Apply the sealers and anti-corrosion materials to the repair area, as necessary. Refer to [Anti-Corrosion Treatment and Repair](#) .
9. Paint the repaired area. Refer to [Basecoat/Clearcoat Paint Systems](#) .
10. Install all related panels and components.
11. Connect the negative battery cable. Refer to [Battery Negative Cable Disconnection and Connection](#) .
12. Enable the SIR system. Refer to [SIR Disabling and Enabling](#) .

