

# Front Inner Hinge Pillar Body Replacement

## Removal Procedure

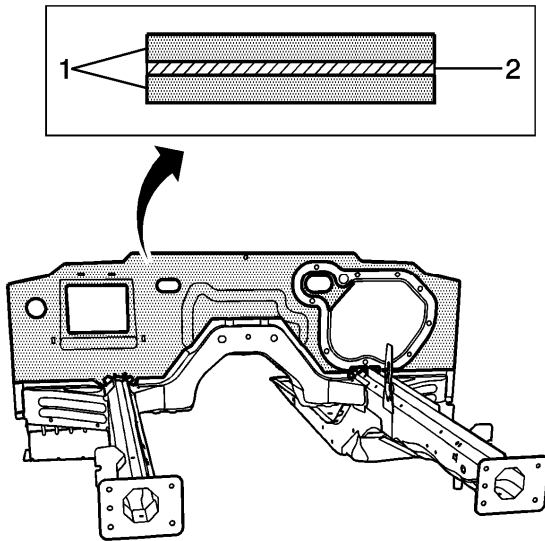

**Important:** Failure to follow this procedure will compromise the structural integrity of the vehicle.

The front of the dash panel is formed from laminated steel. This steel is constructed by bonding 2 pieces of cold rolled steel (1) with a viscosities layer of adhesive (2). MIG welding laminated steel does not meet GM Corporate standards for structural integrity. As an alternative, all factory welds may be replaced by using the rivet and adhesive bond method described in the installation portion of this procedure. The rivet and adhesive bond method must only be used in the areas described in this procedure.

**Caution:** Refer to **Approved Equipment for Collision Repair Caution** in the Preface section.

1. Disable the SIR system. Refer to [SIR Disabling and Enabling](#) .
2. Disconnect the negative battery cable. Refer to [Battery Negative Cable Disconnection and Connection](#) .

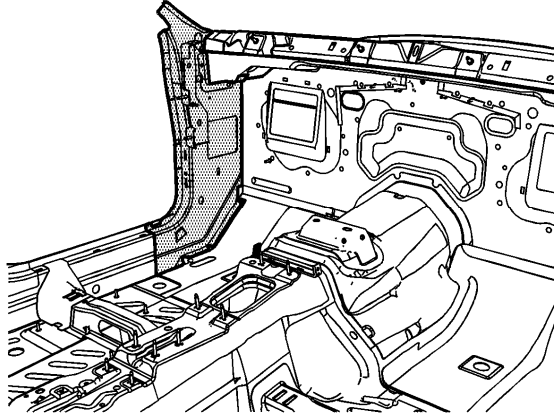

3. Remove the sealers and anti-corrosion materials from the repair area, as necessary. Refer to [Anti-Corrosion Treatment and Repair](#) .
4. Visually inspect the damaged area. Repair as much of the damage as possible. Refer to [Dimensions - Body](#) .

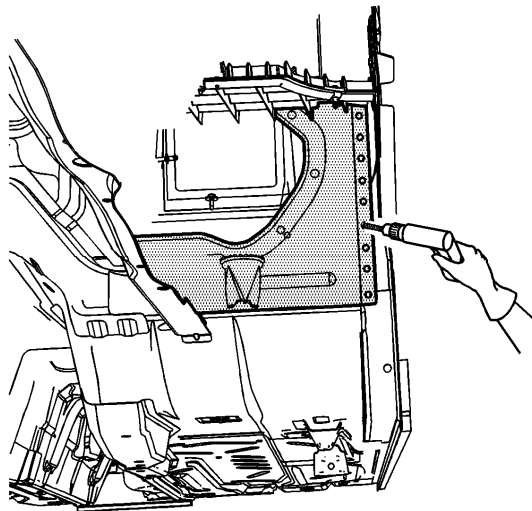

5. Using a 7 mm (17/64 in) drill bit, locate and drill out the factory welds on the weld flange connecting the front inner hinge pillar to the dash panel.

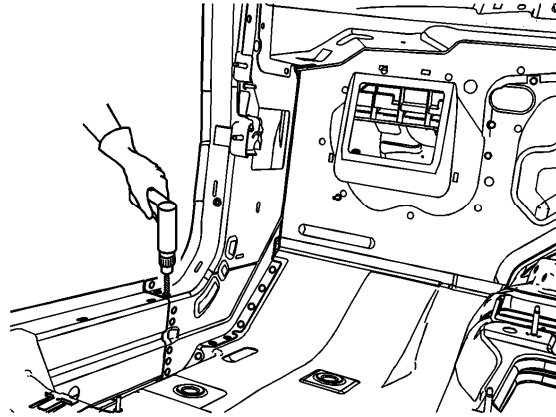

**Important:** Note the number and location of welds for installation of the front inner hinge pillar.

6. Locate and drill out all remaining factory welds, using an 8 mm (5/16 in) spot weld remover.

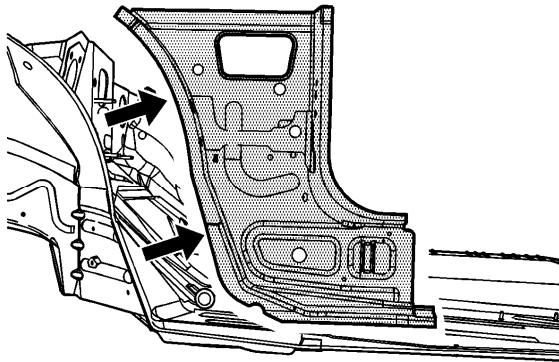

7. Remove the front inner hinge pillar from the vehicle.

## [Installation Procedure](#)

1. Remove the dash support bracket from the service part.
2. Position the service front inner hinge pillar in the vehicle using 3-dimensional measuring equipment. Clamp the front inner hinge pillar in place.

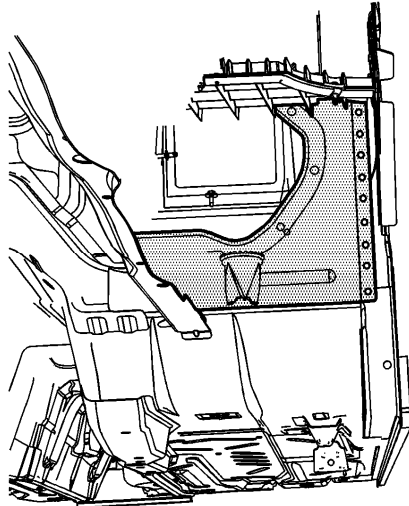

3. Using a 7 mm (17/64 in) bit, drill the rivet attachment holes into the service hinge pillar through the dash in the locations as noted from the factory front inner hinge pillar.

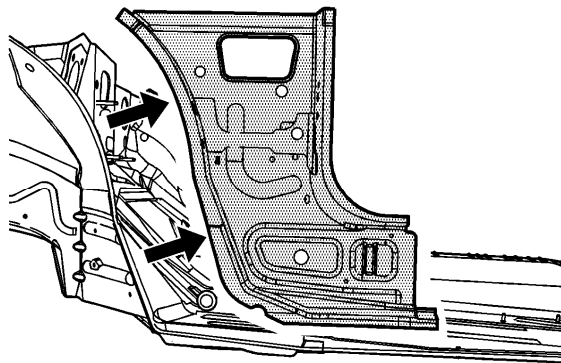

4. Remove the service front inner hinge pillar.

**Important:** If the location of the original plug weld holes can not be determined, space the plug weld holes every 40 mm (1 1/2 in) apart.

5. Drill 8 mm (5/16 in) plug weld holes as necessary in the locations noted from the original assembly.
6. Prepare the MIG weld mating surfaces as necessary.
7. Apply GM-approved Weld-Thru Coating or equivalent to all MIG weld mating surfaces. Refer to [Anti-Corrosion Treatment and Repair](#) .

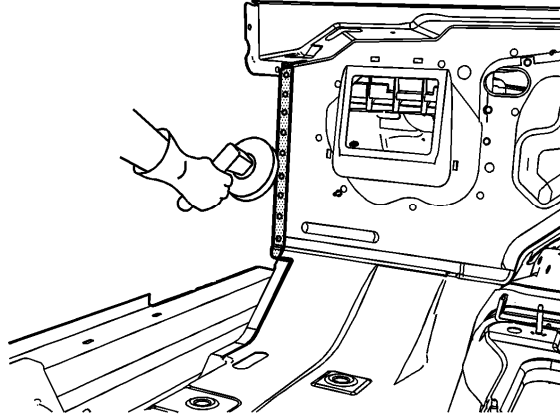

**Important:** Do not damage the corners or thin the metal during the grinding process.

8. Prepare the bonding mating areas by grinding to bare steel the surface of the dash panel and the service front inner hinge pillar flanges.

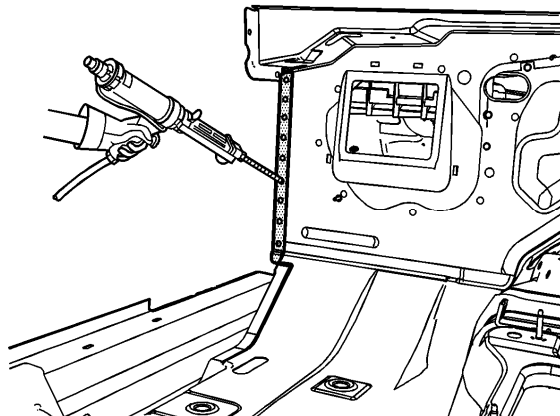

9. Apply a 3-6 mm (1/8-1/4 in) bead of metal panel bonding adhesive to the mating surfaces of the dash panel and the front inner hinge pillar service panel. Refer to [Metal Panel Bonding](#) .

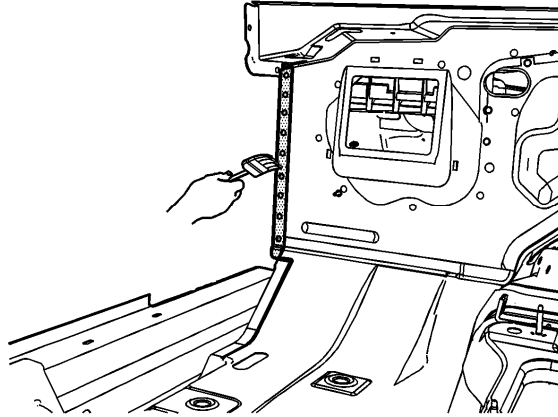

10. Using a small acid brush, spread a coating of adhesive on the mating surfaces. Cover all of the bare metal to ensure corrosion protection.
11. Apply a 3 to 6 mm (1/8 to 1/4 in) bead of metal panel bonding adhesive to the mating surface of the service part.

**Important:** Do not pull the front inner hinge pillar off of the dash after adhesion. To align the parts, slide the front inner hinge pillar against the dash panel.

12. Position the service front inner hinge pillar to the vehicle using 3-dimensional measuring equipment. Clamp the front inner hinge pillar in place.

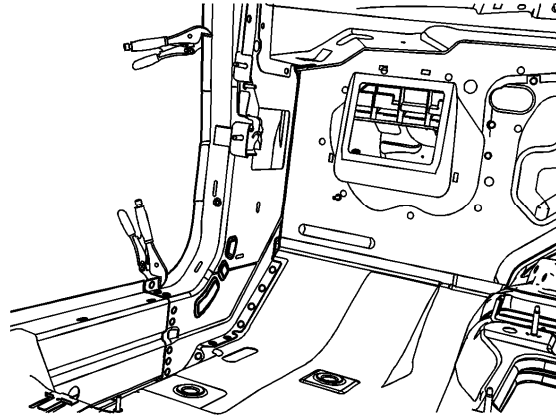

**Important:** Verify the proper positioning of the service front inner hinge pillar prior to riveting and welding.

13. Install the 14 mm (17/32 in) long rivets so that the rivet head contacts the rail extension and the front of the dash panel.

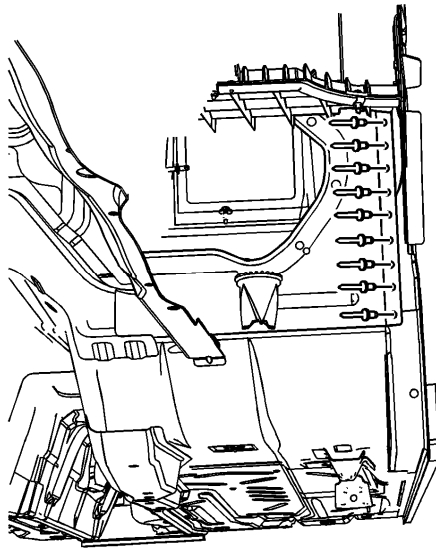

14. Remove the excess adhesive from the front inner hinge pillar bond rivet area.

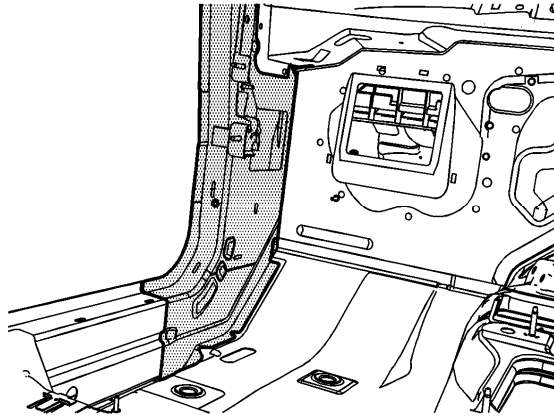

15. Plug weld accordingly.
16. Clean and prepare all of the welded surfaces.
17. Apply the sealers and anti-corrosion materials to the repair area, as necessary.  
Refer to [Anti-Corrosion Treatment and Repair](#) .
18. Paint the repaired area. Refer to [Basecoat/Clearcoat Paint Systems](#) .
19. Install all related panels and components.
20. Connect the negative battery cable. Refer to [Battery Negative Cable Disconnection and Connection](#) .
21. Enable the SIR system. Refer to [SIR Disabling and Enabling](#) .

