

Center Pillar Sectioning - Outer

Removal Procedure

Caution: Refer to **Approved Equipment for Collision Repair Caution** in the Preface section.

Important: The full body-side outer panel comes as a complete assembly and can be replaced at factory seams after the removal of the fixed glass and roof. Any one of these service procedures can be performed separately or in any combination, dependent upon the extent of damage to the vehicle. Sectioning must take place in specified areas only.

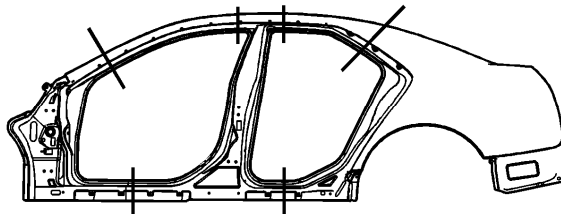

Caution: Sectioning should be performed only in the recommended areas. Failure to do so may compromise the structural integrity of the vehicle and cause personal injury if the vehicle is in a collision.

1. Remove all related panels and components.
2. Disable the SIR system. Refer to [SIR Disabling and Enabling](#) .
3. Disconnect the negative battery cable. Refer to [Battery Negative Cable Disconnection and Connection](#) .
4. Remove the sealers and anti-corrosion materials from the repair area, as necessary, and note their location. Refer to [Anti-Corrosion Treatment and Repair](#) .

Caution: Foam sound deadeners must be removed from areas within 152.4 mm (6 in) of where flame is to be used for body repairs. When reinstalling foam sound deadeners, avoid inhaling fumes as bodily injury may result.

5. Remove sound deadeners, as necessary.
6. Repair as much of the damage as possible.

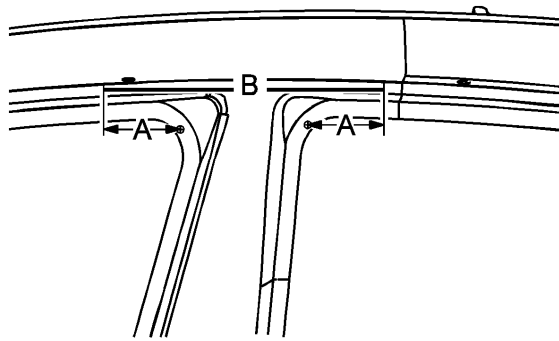

7. At the top of the center pillar, measure 50 mm (2.0 in) out from the diemark (A) and create a vertical cut line. Create a horizontal cut line in the upper crease where the reveal molding mounts (B), allow for a 20 mm (¾ in) overlap.

8. Create cut lines on the rocker panel within the approved sectioning locations.

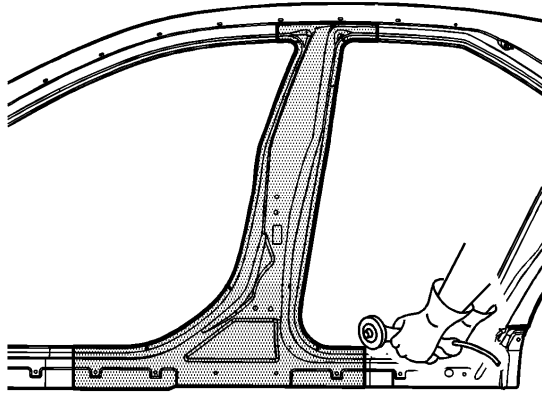

Important: Do not damage any inner panels or reinforcements.

9. Cut the panel where sectioning is to be performed.

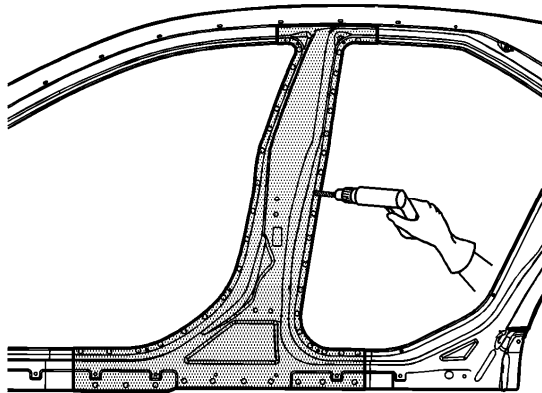

10. Locate and drill out all factory welds. Note the number and location of welds for installation of the service part.
11. Remove the damaged center pillar.

[Installation Procedure](#)

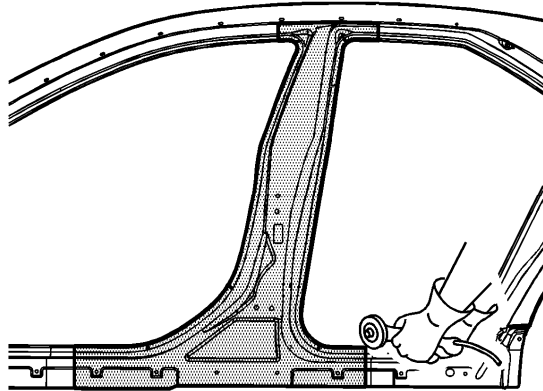

1. Cut the outer center pillar in corresponding locations to fit the remaining original panel. The sectioning joint should be trimmed to allow a gap of $1\frac{1}{2}$ times the metal thickness at the sectioning joint.
2. Create a 100 mm (4 in) backing plate from the unused portion of the service part for the rocker area. Trim the backing plates, as necessary, to fit behind the sectioning joint.
3. In the upper center pillar area, use the existing pillar reinforcement as a backing plate

Important: If the location of the original plug weld holes can not be determined, or if structural weld-thru adhesive is present, space the plug weld holes every 40 mm ($1\frac{1}{2}$ in).

4. Drill 8 mm ($\frac{5}{16}$ in) along the sectioning cut on the remaining original part. Locate these holes 13 mm ($\frac{1}{2}$ in) from the edge of part and spaced 40 mm ($1\frac{1}{2}$ in) apart.
5. Drill 8 mm ($\frac{5}{16}$ in) plug weld holes in the service part, as necessary, in the locations noted from the original panel and along the sectioning cut.
6. Prepare all mating surfaces, as necessary.
7. Apply Weld-Thru Coating to all mating surfaces. Refer to [Anti-Corrosion Treatment and Repair](#) .
8. Fit the backing plates halfway into the sectioning joints, clamp in place and plug weld to the vehicle.
9. Align outer center pillar using 3-dimensional measuring equipment.

10. Plug weld accordingly.

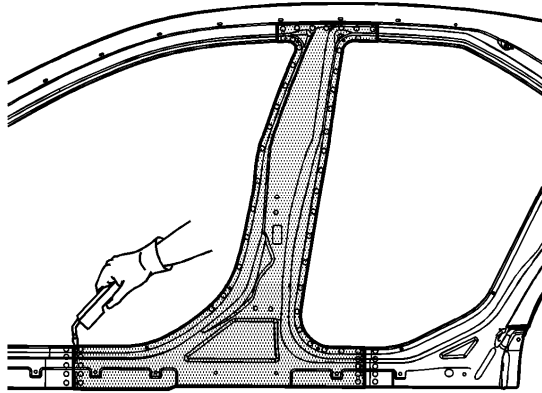

11. To create a solid weld with minimum heat distortion, make a 25 mm (1 in) stitch weld along the seam with 25 mm (1 in) gaps between them. Go back and complete the stitch weld.
12. Clean and prepare all of the welded surfaces.
13. Apply the sealers and anti-corrosion materials to the repair area, as necessary. Refer to [Anti-Corrosion Treatment and Repair](#) .
14. Paint the repaired area. Refer to [Basecoat/Clearcoat Paint Systems](#) .
15. Install all of the related panels and components.
16. Connect the negative battery cable. Refer to [Battery Negative Cable Disconnection and Connection](#) .
17. Enable the SIR system. Refer to [SIR Disabling and Enabling](#) .

