

# Panel Identification

**FIGURE Catera Body Structure(c)**

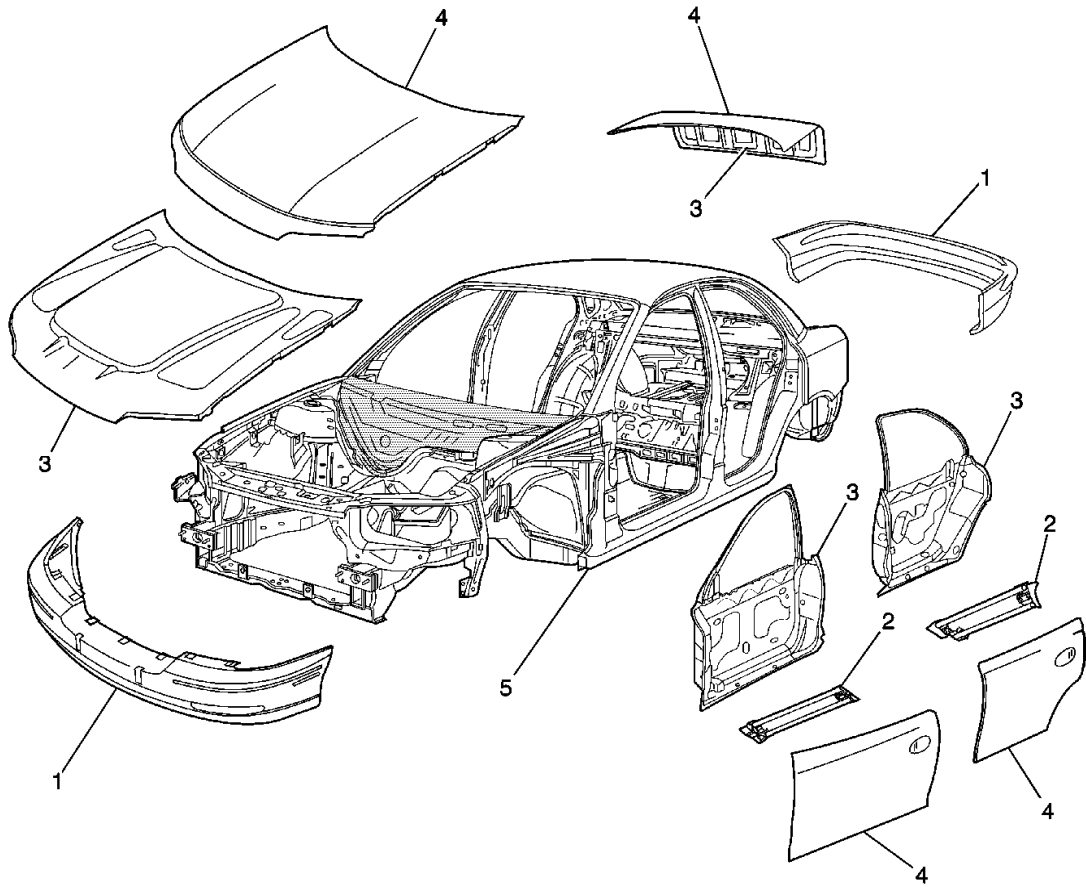

- (1) Ethyleny-Propylene-Terpolymer (EPDM)
- (2) High Strength Low-Alloy (HSLA) Steel
- (3) Two-Sided Galvanized Steel
- (4) Single-Sided Galvanized Steel
- (5) Thick Film Cataphoretic Dip Priming (TCDP)

The body structure forms a protective steel safety cage around the passenger compartment, while absorbing the energy from a collision.

---