

Body Rear End Panel Replacement

Description

This repair procedure gives you the option of using an installation procedure for either metal-inert gas (MIG) welding or adhesive bonding.

Removal Procedure

Caution: Refer to [Approved Equipment for Collision Repair Caution](#) in Cautions and Notices.

1. Disable the SIR system. Refer to [SIR Disabling and Enabling](#) .
2. Disconnect the negative battery cable. Refer to [Battery Negative Cable Disconnection and Connection](#) .
3. Remove all related panels and components.
4. Repair as much of the damage as possible. Refer to [Dimensions - Body](#) .
5. Remove the sealers and anti-corrosion materials from the repair area, as necessary. Refer to [Anti-Corrosion Treatment and Repair](#) .

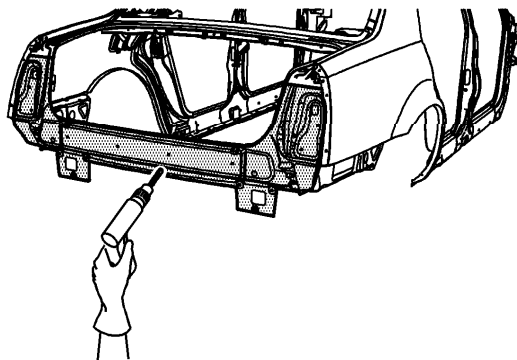

Important: Note the number and location of the factory welds for installation of the rear end panel.

6. Locate and drill out all the necessary factory welds.

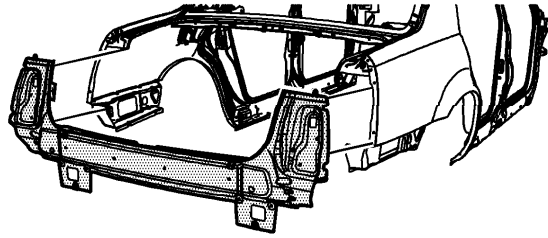

7. Remove the rear end panel.

Installation Procedure (Metal-Inert Gas (MIG) Welding)

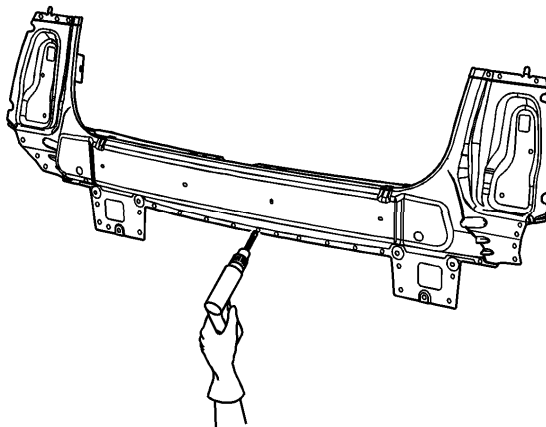

Important: If the location of the original plug weld holes cannot be determined, space the plug weld holes every 40 mm (1½ in) apart.

1. Drill 8 mm (5/16 in) plug weld holes in the service part as necessary in the locations noted from the original panel.
2. Prepare all mating surfaces, as necessary.
3. Apply GM-approved Weld-Thru Coating or equivalent to all mating surfaces. Refer to [Anti-Corrosion Treatment and Repair](#) .

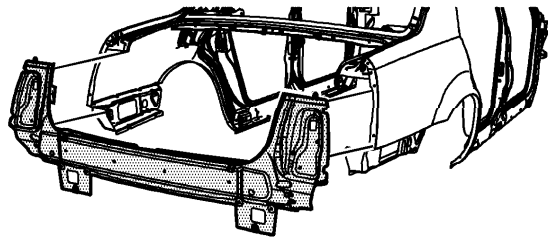

4. Position the rear end panel on the vehicle. Use 3-dimensional measuring equipment to locate the panel.
5. Clamp the panel in place.

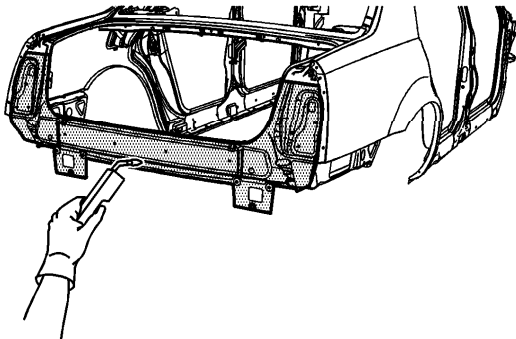

6. Plug weld accordingly.

7. Clean and prepare all of the welded surfaces.
8. Install all of the related panels and components.
9. Apply the sealers and anti-corrosion materials to the repair area, as necessary. Refer to [Anti-Corrosion Treatment and Repair](#) .
10. Paint the repaired area. Refer to [Basecoat/Clearcoat Paint Systems](#) .
11. Connect the negative battery cable. Refer to [Battery Negative Cable Disconnection and Connection](#) .
12. Enable the SIR system. Refer to [SIR Disabling and Enabling](#) .

Installation Procedure (Adhesive Bonding)

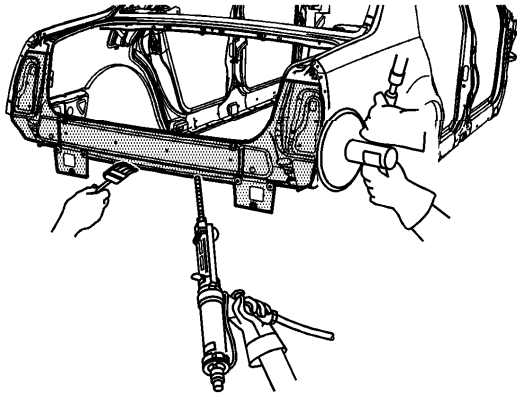

1. Grind the surface of the body mating flanges to bare steel.
2. Grind the body rear end panel mating flanges to remove the E-coating. Take care not to damage the corners or thin the metal during the grinding operation.
3. Clean the mating surfaces.

Important: The adhesive has a working time of 40-50 minutes. Do not allow the adhesive to totally cure off the vehicle, as proper alignment of the panel to the body will be difficult.

4. Apply a bead of metal panel bonding adhesive GM P/N 12378567 (Canadian P/N 88901675) or equivalent to a thickness of 3-6 mm (1/8-1/4 in) to both of the mating surfaces.
5. Using a small acid brush, spread a coat of adhesive to cover all the bare metal surfaces to ensure corrosion protection.

6. Apply a 9-13 mm (3/8-1/2 in) bead of metal panel bonding adhesive GM P/N 12378567 (Canadian P/N 88901675) or equivalent to the service part mating surface.

Important: Do NOT pull the panels apart after joined together. Slide the panels against each other to realign the panels.

7. Install the body rear end panel to the vehicle.
8. Clamp the body rear end panel into position, as required.
9. Using lacquer thinner remove the excess adhesive from the panel area.
10. Apply the sealers and anti-corrosion materials to the repair area, as necessary. Refer to [Anti-Corrosion Treatment and Repair](#) .
11. Paint the repair area. Refer to [Basecoat/Clearcoat Paint Systems](#) .
12. Install all related panels and components.
13. Connect the negative battery cable. Refer to [Battery Negative Cable Disconnection and Connection](#) .
14. Enable the SIR system. Refer to [SIR Disabling and Enabling](#) .