

Rail Replacement Rear Side Underbody

Removal Procedure

Caution: Refer to [Approved Equipment for Collision Repair Caution](#) in Cautions and Notices.

1. Disable the SIR system. Refer to [SIR Disabling and Enabling](#) .
2. Disconnect the negative battery cable. Refer to [Battery Negative Cable Disconnection and Connection](#) .

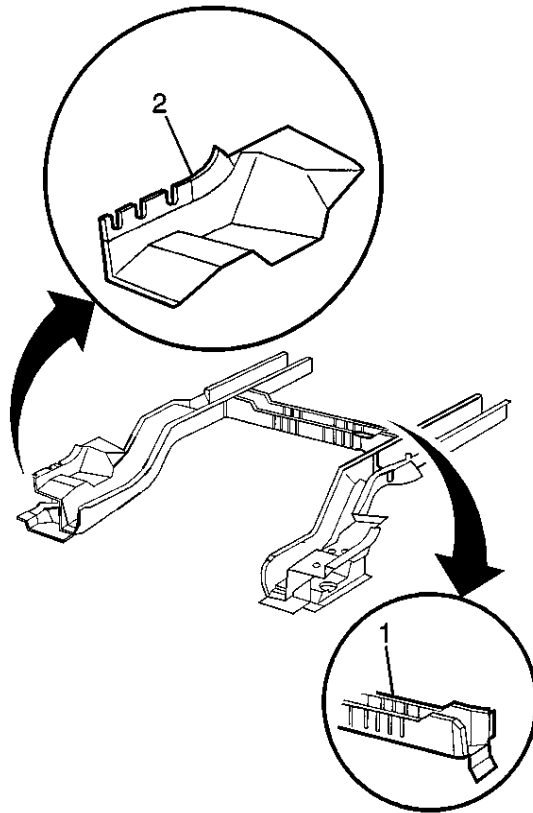

Important: Complete rear rail replacement can be performed by drilling out all the factory welds. The outboard flange at the forward end of the rail must be cut in one location and bent upward (2). The bottom flange of the crossbar must be bent downward (1). The rear rail can then be lowered from the vehicle. When installing the service rail, the outboard flange must be cut and bent up, installed, then straightened, and aligned. Weld as necessary.

3. Remove all related panels and components.
4. Repair as much of the damaged area as possible. Refer to [Dimensions - Body](#) .
5. Remove the sealers and anti-corrosion materials from the repair area, as necessary. Refer to [Anti-Corrosion Treatment and Repair](#) .

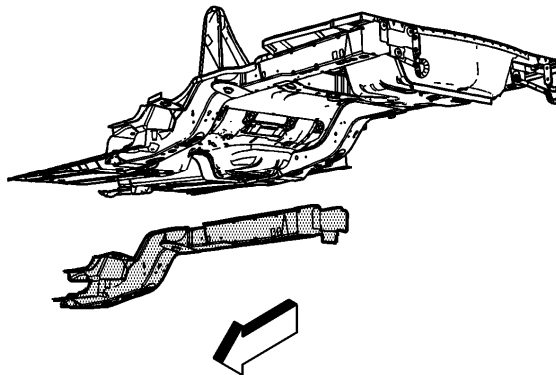

6. Locate and drill out all necessary factory welds.
7. Remove the rear rail.

Installation Procedure

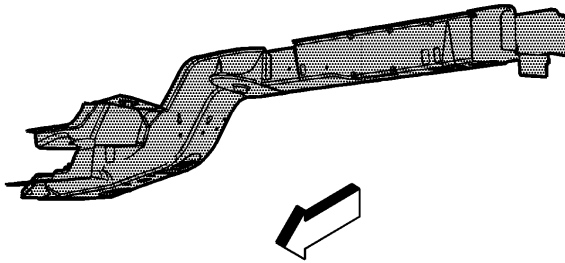

Important: If the location of the original plug weld holes cannot be determined, space the plug weld holes every 40 mm (1 1/2 in) apart.

1. Drill 8 mm (5/16 in) plug weld holes in the service part, as necessary in the locations noted from the original panel.
2. Prepare all mating surfaces for welding, as necessary.
3. Apply GM-approved Weld-Thru Coating or equivalent to all mating surfaces. Refer to [Anti-Corrosion Treatment and Repair](#) .

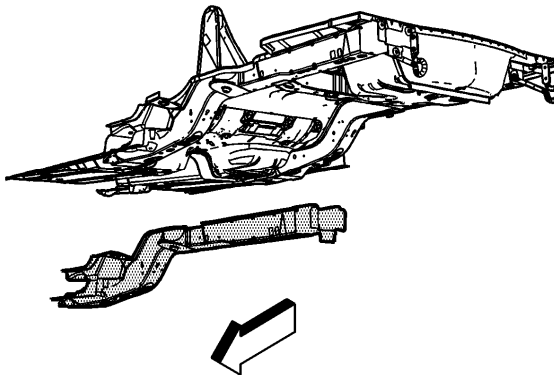

Important: The service part includes a rear wheelhouse extension.

4. Position the rear rail to the vehicle using 3-dimensional measuring equipment. Clamp the rail in place.

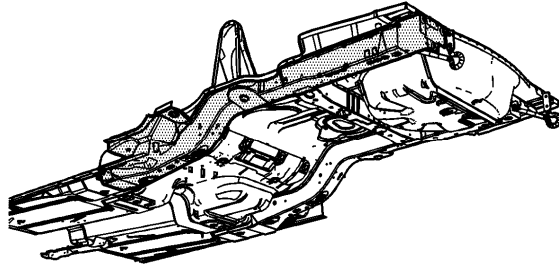

5. Plug weld accordingly.
6. Install all of the related panels and components.
7. Apply the sealers and anti-corrosion materials to the repair area, as necessary. Refer to [Anti-Corrosion Treatment and Repair](#) .
8. Paint the repaired area. Refer to [Basecoat/Clearcoat Paint Systems](#) .
9. Connect the negative battery cable. Refer to [Battery Negative Cable Disconnection and Connection](#) .
10. Enable the SIR system. Refer to [SIR Disabling and Enabling](#) .