

Roof Outer Panel Replacement

Removal Procedure

The roof panel is attached to the steel roof structure with beads of adhesive on the sides. The roof panel is attached to the windshield and the rear window, with spot welds. Replacement of the roof panel can be performed using conventional procedures. The windshield and the rear window must be removed. Refer to [Windshield Replacement](#) .

Caution: Refer to [Approved Equipment for Collision Repair Caution](#) in Cautions and Notices.

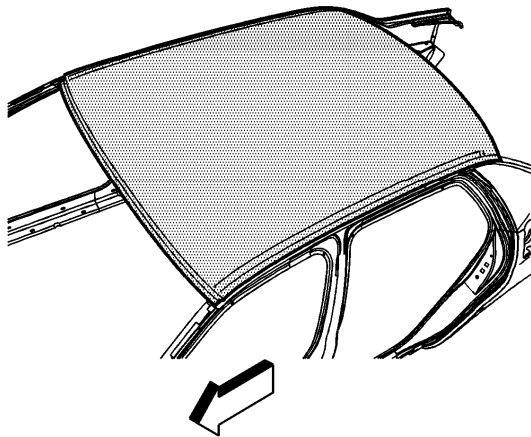

1. Disable the SIR system. Refer to [SIR Disabling and Enabling](#) .
2. Disconnect the negative battery cable. Refer to [Battery Negative Cable Disconnection and Connection](#) .
3. Take note of the gap sizes along the perimeter of the roof panel to the headers, the glass, and the doors.
4. Remove all related panels and components.
5. Repair as much of the damaged area as possible. Refer to [Dimensions - Body](#) .

Important: Do not damage any inner panels or reinforcements that are cut in the board of the roof insurance.

6. Note the location and remove the sealers and anti-corrosion materials from the repair area, as necessary. Refer to [Anti-Corrosion Treatment and Repair](#) .

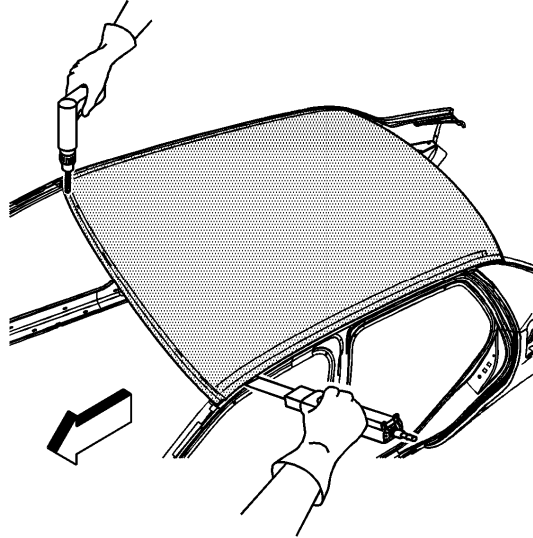

7. Locate and mark all factory welds.
8. Drill out all factory welds. Note the number and locations of the welds for installation of the service assembly.
9. Cut the adhesive with an appropriate tool.

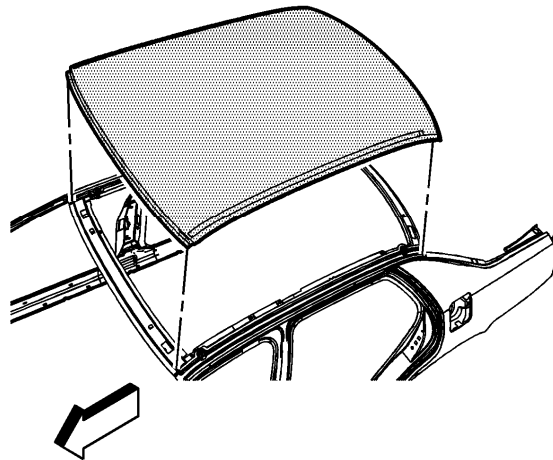

10. Remove the damaged roof panel.

Installation Procedure

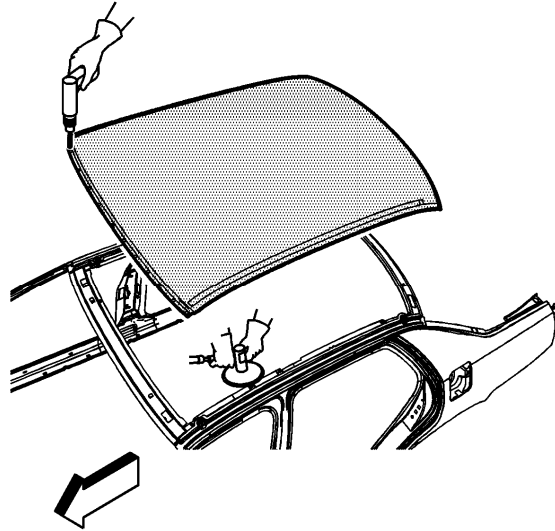

1. Clean and prepare the mating surfaces for welding.
2. Drill 8 mm (5/16 in) holes for plug welding along the windshield and rear window edges of the service panel as noted from the original panel.
3. Prepare the plug weld mating surfaces, as necessary.
4. Apply GM-approved Weld-Thru Coating or equivalent to all mating surfaces. Refer to [Anti-Corrosion Treatment and Repair](#) .
5. Prepare the bond mating areas by grinding the body mating and the service part flanges to bare steel.

Important: Do not damage the corners or the thin metal during the grinding process.

6. Clean the mating surfaces.

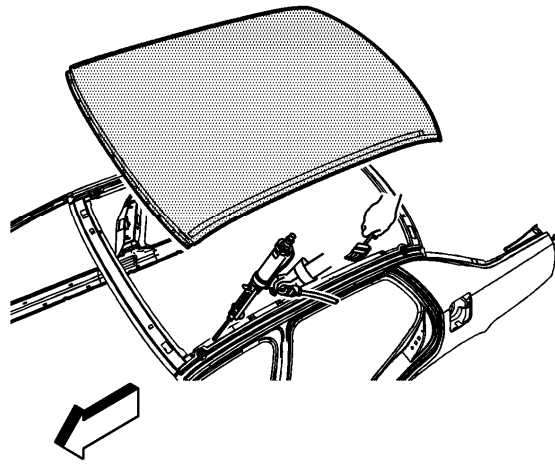

Important: The adhesive has a 40-50 minute working time. Do NOT allow the adhesive to cure prior to installing the service part.

7. Apply a 3-6 mm (1/8 to 1/4 in) bead of metal panel bonding adhesive GM P/N 12378567 (Canadian P/N 88901675) or equivalent to both of the mating surfaces.
8. Using a small acid brush, spread a coat of adhesive to both of the mating surfaces. Cover all of the bare metal to ensure corrosion protection.

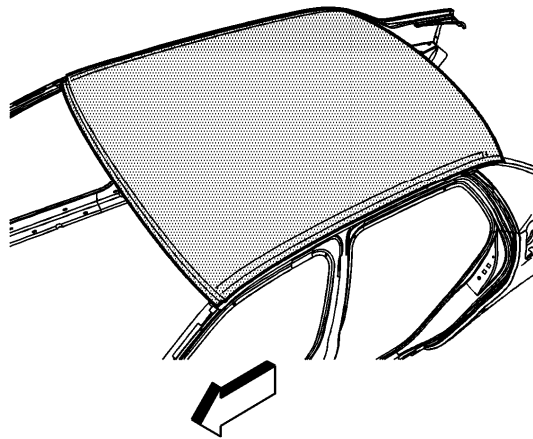

9. Position the roof panel on the vehicle.
10. Verify the fit of the panel.
11. Clamp the panel into place.
12. Plug weld accordingly.

13. Apply the sealers and anti-corrosion materials to the repair area, as necessary.
Refer to [Anti-Corrosion Treatment and Repair](#) .
14. Paint the repair area. Refer to [Basecoat/Clearcoat Paint Systems](#) .
15. Install all related panels and components.
16. Connect the negative battery cable. Refer to [Battery Negative Cable Disconnection and Connection](#) .
17. Enable the SIR system. Refer to [SIR Disabling and Enabling](#) .