

Front Compartment Front Rail Sectioning

Removal Procedure

Caution: Refer to [Approved Equipment for Collision Repair Caution](#) in Cautions and Notices.

Important:

- If the damage exceeds the recommended area for sectioning and the rail cannot be straightened, then replace the entire rail.
- Sectioning procedures have been developed to simplify the repair of the lower rails, as long as the damage rearward of the sectioning location can be repaired to factory specifications.
- Failure to follow the instructions may lead to improper rail sectioning, which may compromise the structural integrity of the vehicle.

1. Disable the SIR system. Refer to [SIR Disabling and Enabling](#) .
2. Disconnect the negative battery cable. Refer to [Battery Negative Cable Disconnection and Connection](#) .

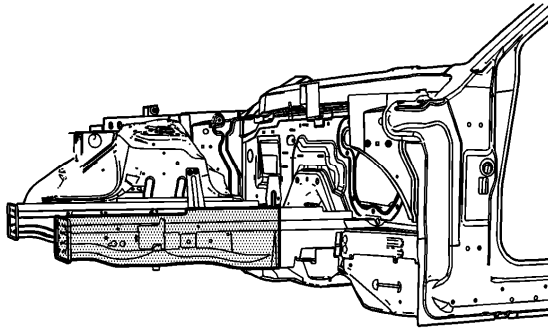

3. Remove all of the related panels and components.
4. Repair as much as the damage as possible to factory specifications.

Caution: Refer to [Foam Sound Deadeners Caution](#) in Cautions and Notices.

5. Note the location and remove the sealers and anti-corrosion materials from the repair area, as necessary. Refer to [Anti-Corrosion Treatment and Repair](#).
6. Perform the necessary procedures to gain access to the repair.

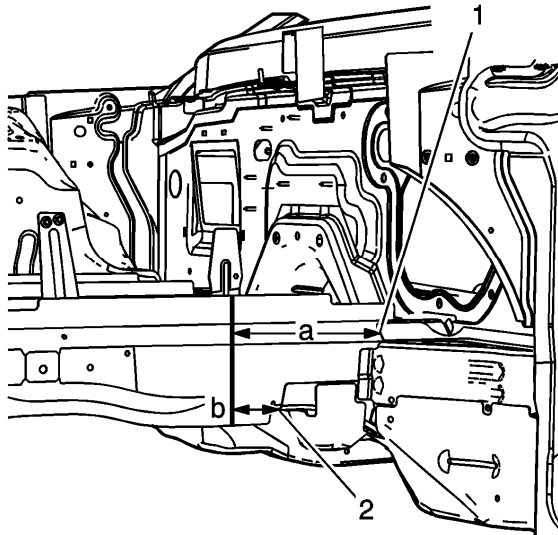

7. On the outboard side of the rail, locate the upper reinforcement bracket (1). On the bottom of the rail, locate the lower reinforcement bracket (2).
8. Measure 280 mm (11 in) (a) forward from the edge of the upper reinforcement bracket (1). Make a mark.

9. Measure 100 mm (4 in) (b) forward from the edge of the lower reinforcement bracket (2). Make a mark.

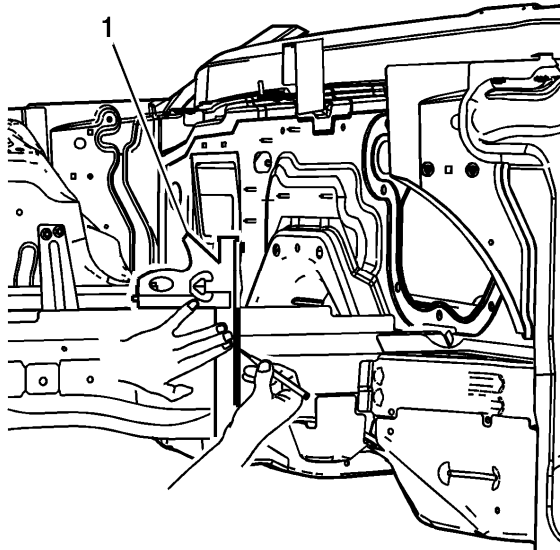

10. Using the two marks, align a sliding square or similar tool (1) square to the surface to the vertical walls of the frame rail.
11. Scribe a line to both sides of the frame rails.

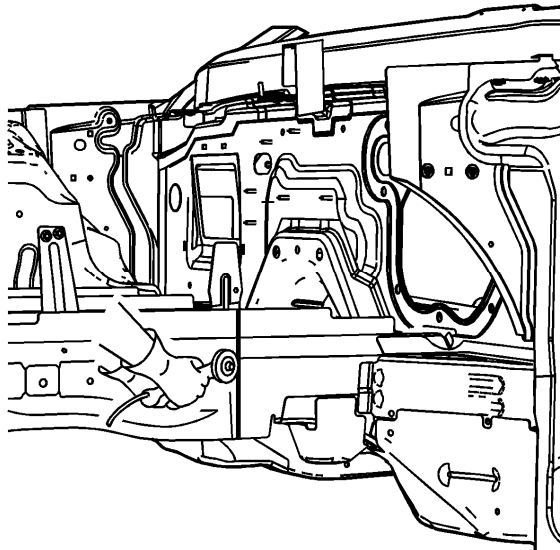

12. Cut the frame rail at the marked location.

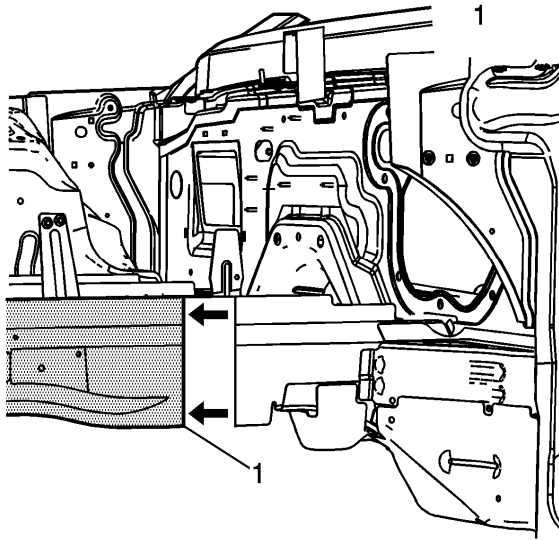

13. Remove the damaged frame rail section (1) from the vehicle.

Installation Procedure

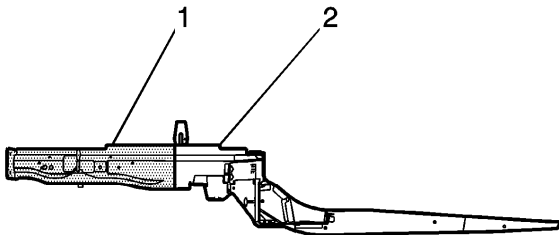

1. In order to create the rail section service part (1), cut the full rail service part (2).

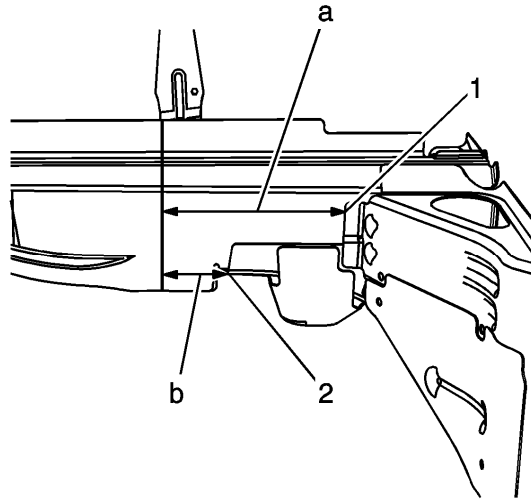

2. On the outboard side of the full rail service part, locate the upper reinforcement bracket (1). On the bottom of the rail, locate the lower reinforcement bracket (2).
3. Measure 280 mm (11 in) (a) forward from the edge of the upper reinforcement bracket (1). Make a mark.
4. Measure 100 mm (4 in) (b) forward from the edge of the lower reinforcement bracket (2). Make a mark.

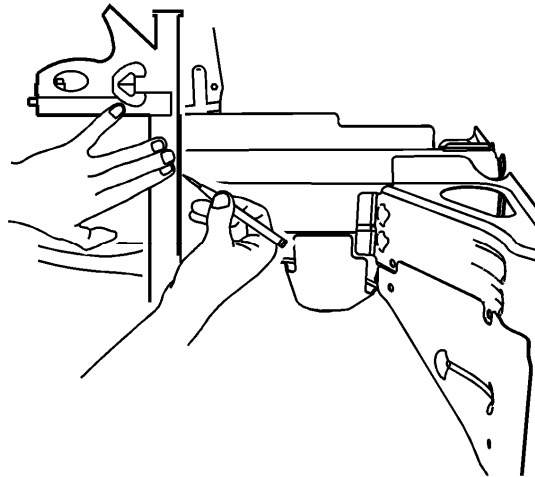

5. Using the two marks, align a sliding square or similar tool (1) square to the surface to the vertical walls of the frame rail.

6. Scribe a line to both sides of the frame rails.

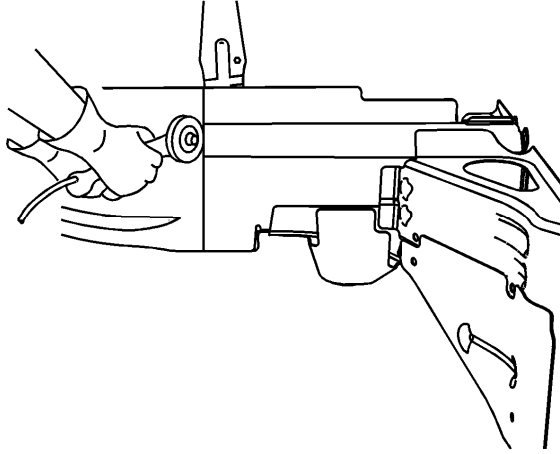

7. Cut the frame rail at the marked location.

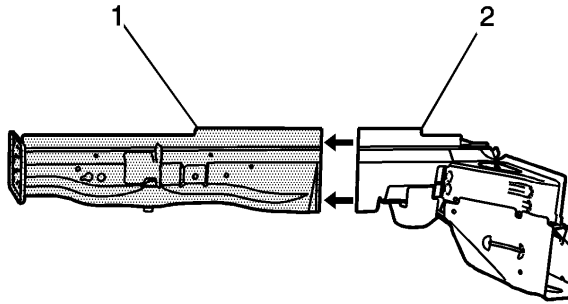

8. Remove the rail section (1) from the full rail service part.

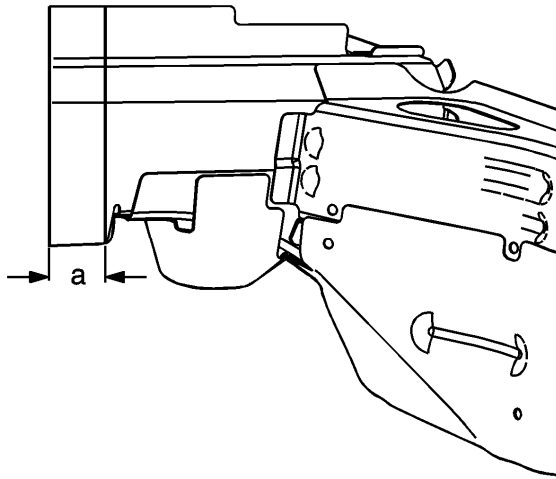

9. From the unused portion of the full rail service part, measure, mark, and cut a 50 mm (2-in) (a) section of rail to be used as a sleeve or backing plate for the sectioning joint.
10. Cut through the top and the bottom of the sleeve to create two individual pieces that can be installed in the near rail section.
11. Trim the pieces as necessary to provide a flush fit along the inner surface of the new rail section.

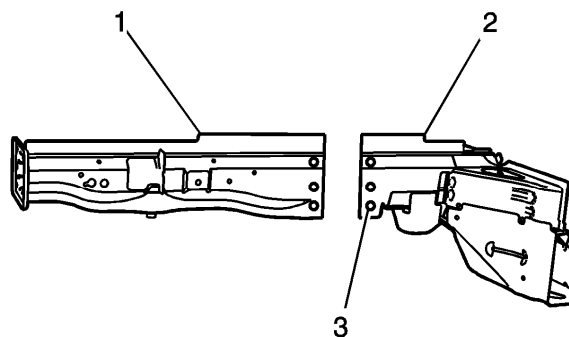

12. Drill 6 8-mm (5/16-in) (3) plug weld holes in the rail section (1), so that there are 3 holes equally spaced on each side of the rail.
13. Drill 6 8-mm (5/16-in) (3) plug weld holes in the vehicle rail (2), so that there are 3 holes equally spaced on each side of the rail.

14. Clean and prepare all of the welded surfaces.
15. Apply GM-approved Weld-Thru Coating or equivalent to all mating surfaces.
Refer to [Anti-Corrosion Treatment and Repair](#) .

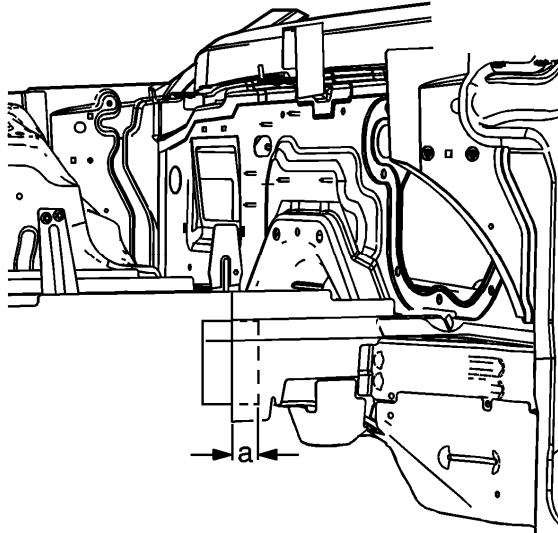

16. Install the 2 sleeve pieces 25 mm (1 in) (a) into the vehicle frame rail.
17. Plug weld accordingly at each plug weld location.

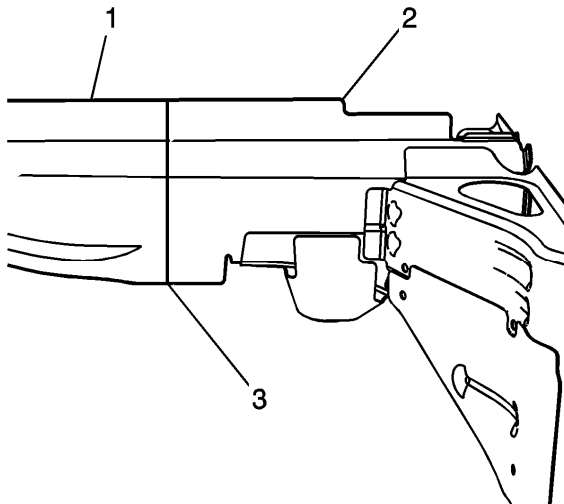

18. Position the service rail section (1) to the existing rail (2).
19. Maintain a gap (3) of 1 1/2 times the frame rail metal thickness at the sectioning joint. Clamp in place.
20. Inspect the frame measurements 3-dimensional to ensure proper position of the service rail section.
21. Plug weld accordingly at each plug weld location.

22. Inspect the frame measurements 3-dimensional to ensure proper position of the service rail section.

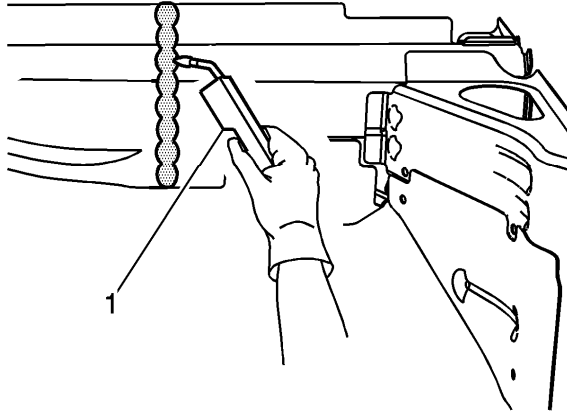

23. Stitch weld along the entire sectioning joint. Make 25 mm (1 in) welds along the seam with 25 mm (1 in) gaps between.
24. Complete the stitch weld.
25. Clean and prepare all of the welded surfaces.
26. Install all of the related panels and components.
27. Apply the sealers and anti-corrosion materials to the repair area, as necessary.
Refer to [Anti-Corrosion Treatment and Repair](#) .
28. Paint the repaired area. Refer to [Basecoat/Clearcoat Paint Systems](#) .
29. Connect the negative battery cable. Refer to [Battery Negative Cable Disconnection and Connection](#) .
30. Enable the SIR system. Refer to [SIR Disabling and Enabling](#) .