

# Panel Replacement - Door Outer

## Removal Procedure

### **Caution**

Refer to [Approved Equipment for Collision Repair Caution](#) in Cautions and Notices.

### **Important**

Before beginning the repair, refer to [Metal Panel Bonding](#) for proper adhesive applicator preparations and general information.

1. Disconnect the negative battery cable. Refer to [Battery Negative Cable Disconnect/Connect Procedure](#) in Engine Electrical.
2. Disable the SIR system. Refer to [SIR Disabling and Enabling Zones](#) in SIR.
3. Remove the door from the vehicle. Refer to [Door Replacement - Front](#) in Doors.
4. Remove the outer door handle. Refer to [Door Handle Replacement - Front Outside](#) in Doors.
5. Remove the outside rear view mirror. Refer to [Mirror Replacement - Power](#) in Doors.

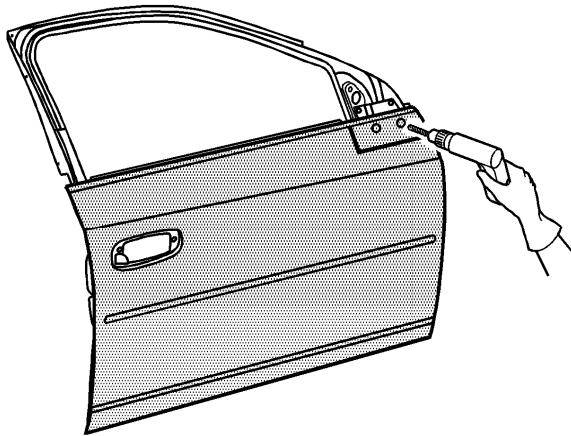

6. Cut a hole in the outer door panel to access the welds on the belt reinforcement.
7. Drill out the spot welds that attach the outer belt reinforcement to the outer door panel flange.

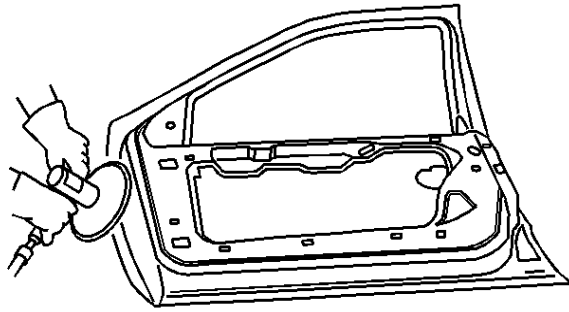

8. Grind the edges of the door outer panel to separate the outer door panel from the door shell.

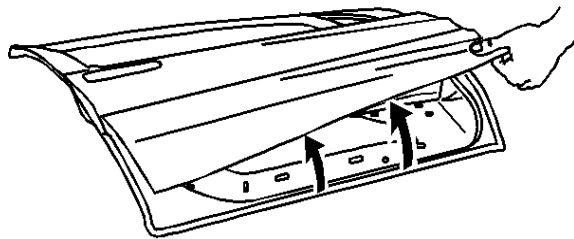

9. Remove the outer door panel.
10. Remove the sealers and anti-corrosion materials from the repair area, as necessary. Refer to [Anti-Corrosion Treatment and Repair](#) in Paint and Coatings.

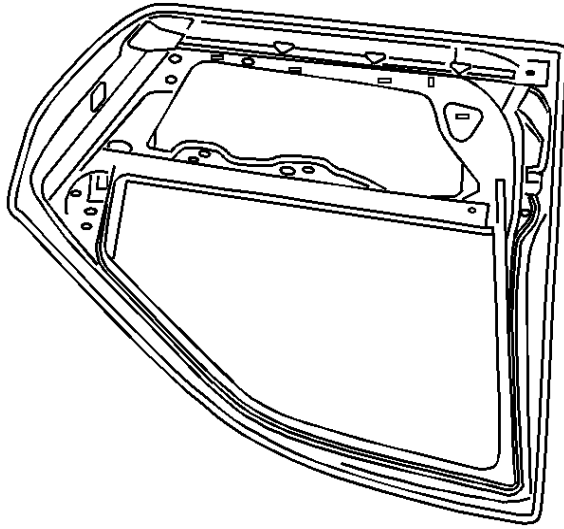

11. Straighten the edges of the door shell.

### Installation Procedure

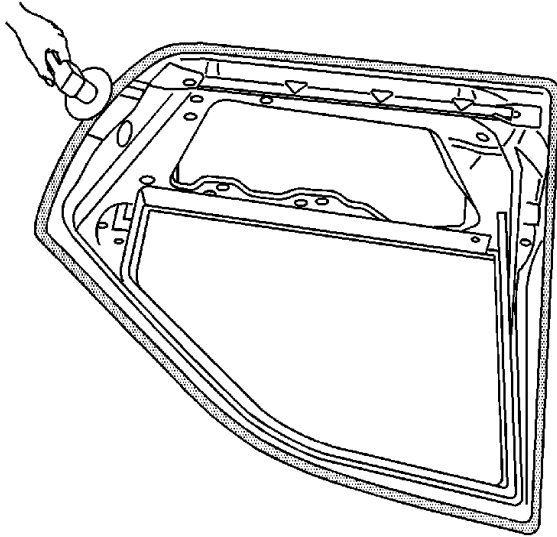

1. Grind the surface of the door shell mating flanges to bare steel.

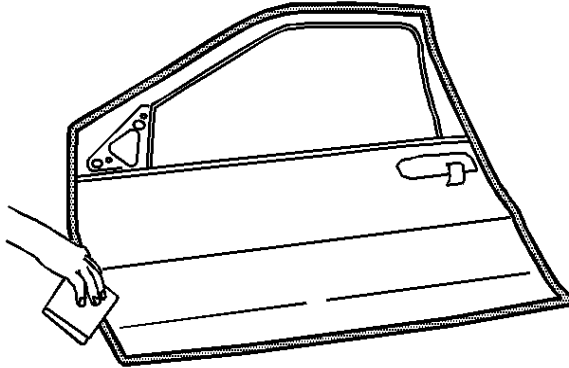

2. Scuff the opposing mating surfaces of the door outer panel to remove the gloss of the E-Coat.

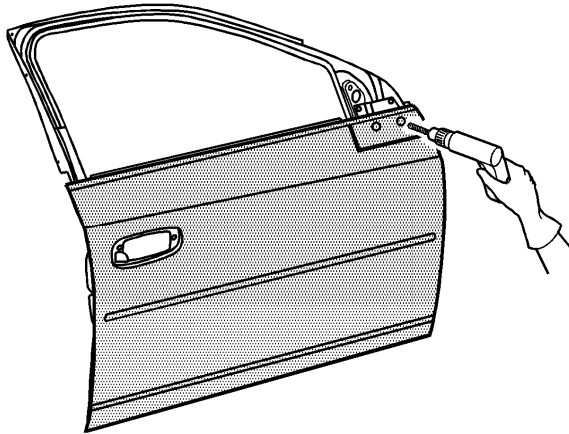

3. Drill 8 mm (5/16 in) plug weld holes as necessary in locations noted from the original panel.

**Important**

If the location of the original plug weld holes can not be determined, or if structural weld-thru adhesive is present, space the plug weld holes every 40 mm (1½ in) apart.

4. Prepare all mating surfaces as necessary.
5. Install and position the replacement service section using 3-dimensional measuring.

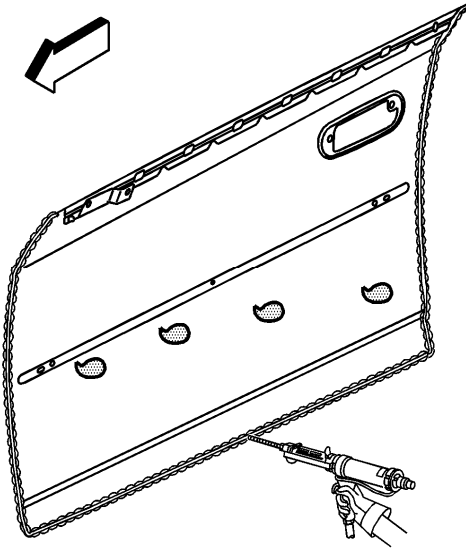

### **Important**

The adhesive has a 40-50 minute working time. Do not allow the door to totally cure off the vehicle, as proper alignment of the door outer panel to the door shell will be difficult.

6. Apply a 3-6 mm (1/8 to 1/4 in) bead of metal panel bonding adhesive GM P/N 12378566/7 (Canadian P/N 88901674/5) or equivalent to both of the mating surfaces.
7. Using a small acid brush, spread a coat of adhesive to cover all the bare metal surfaces to ensure corrosion protection.
8. Apply a 9-13 mm (3/8 to 1/2 in) bead of metal panel bonding adhesive GM P/N 12378566/7 (Canadian P/N 88901674/5) or equivalent to the service part mating surfaces.

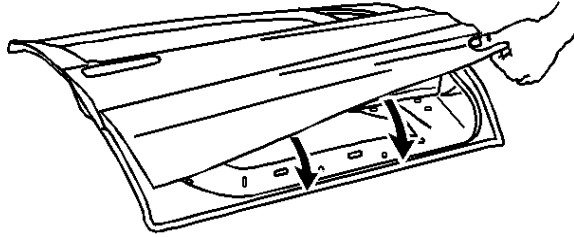

### **Important**

**DO NOT** pull the panels apart after being joined together. Slide the panels against each other to realign the panels.

9. Install the door outer panel to the door shell.
10. Clamp the door outer panel into position as required.

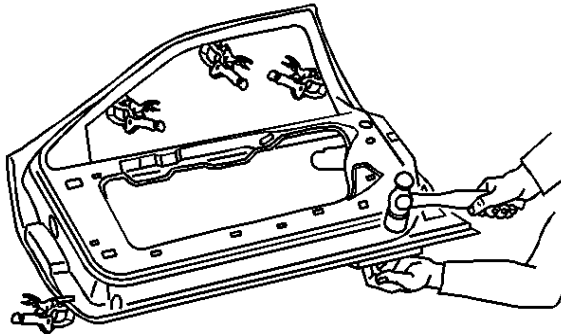

11. Using a hammer re-hem the hem flanges around the door shell . Continue to hammer in stages along the hem flanges.
12. Using lacquer thinner remove the excess adhesive from the door panel area.

13. Install the door to the vehicle check the door outer panel for proper alignment, adjust the alignment as required. Refer [Door Replacement - Front](#) in Doors.
14. Remove the door from the vehicle to complete the repair.

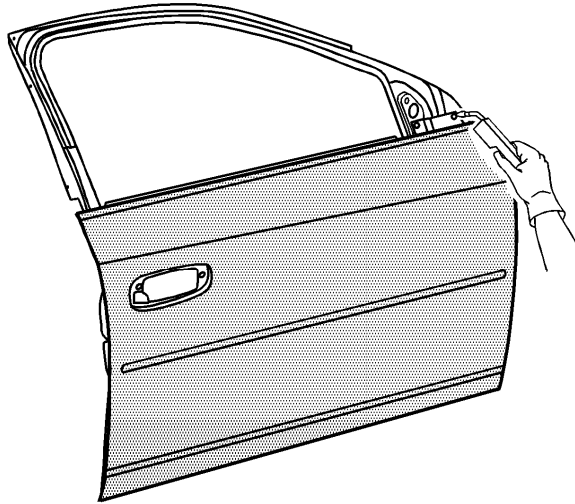

15. Metal-Inert Gas (MIG) weld the door outer panel to the door frame in the locations noted at the upper door frame.
16. Clean and prepare all welded surfaces.

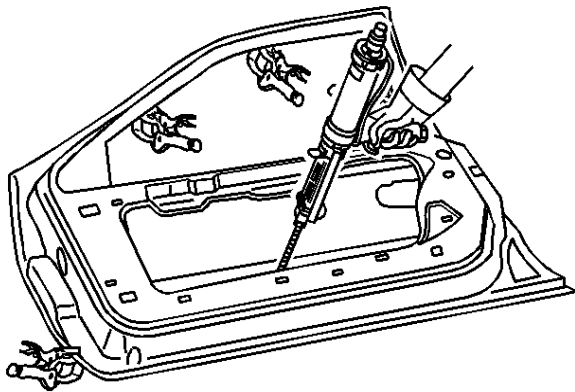

17. Apply Fusor super flexible anti-flutter foam - fast set, Fusor P/N 121/124 or equivalent in 4-5 evenly spaced locations between the door outer panel and the inner safety beam.
18. Apply sealers and anti-corrosion materials to the repair area as necessary. Refer to [Anti-Corrosion Treatment and Repair](#) in Paint and Coatings.

19. Paint the repaired area. Refer to [Basecoat/Clearcoat Paint Systems](#) in Paint and Coatings.
20. Install the door to the vehicle. Inspect the door outer panel for proper alignment and adjust the alignment as required. Refer to [Door Replacement - Front](#) in Doors.
21. Install the outer door handle. Refer to [Door Handle Replacement - Front Outside](#) in Doors.
22. Install the outside rear view mirror. Refer to [Mirror Replacement - Power](#) in Doors.
23. Enable the SIR system. Refer to [SIR Disabling and Enabling Zones](#) in SIR.
24. Connect the negative battery cable. Refer to [Battery Negative Cable Disconnect/Connect Procedure](#) in Engine Electrical.