

# Rear End Panel Replacement

## Removal Procedure

**Caution:** Refer to [Approved Equipment for Collision Repair Caution](#) in Cautions and Notices.

1. Disable the SIR system. Refer to [SIR Disabling and Enabling](#) in SIR.
2. Disconnect the negative battery cable. Refer to [Battery Negative Cable Disconnection and Connection](#) in Engine Electrical.

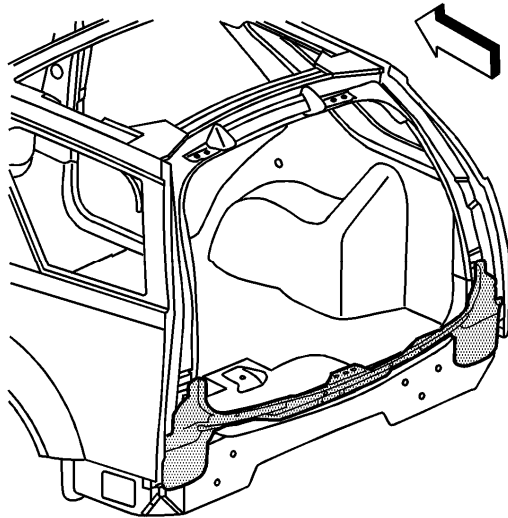

**Caution:** Sectioning should be performed only in the recommended areas. Failure to do so may compromise the structural integrity of the vehicle and cause personal injury if the vehicle is in a collision.

**Important:** This panel is replaced at factory seams.

3. Remove all related panels and components.
4. Repair as much of the damage as possible .
5. Remove the sealers and anti-corrosion materials from the repair area, as necessary. Refer to [Anti-Corrosion Treatment and Repair](#) in Paint and Coatings.

**Important:** Note the number and location of the factory welds for installation of the rear end panel.

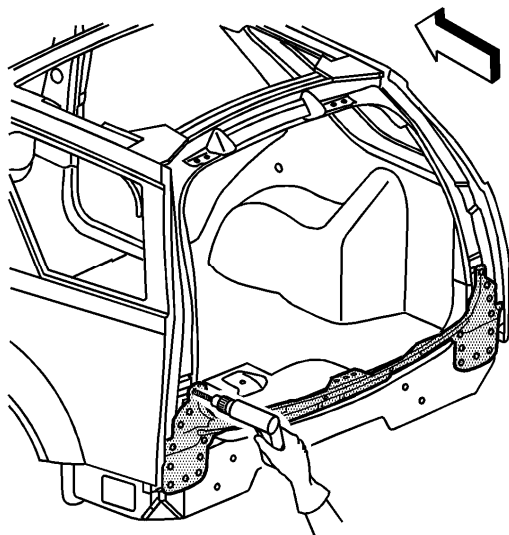

6. Locate, mark, and drill out all the necessary factory welds.

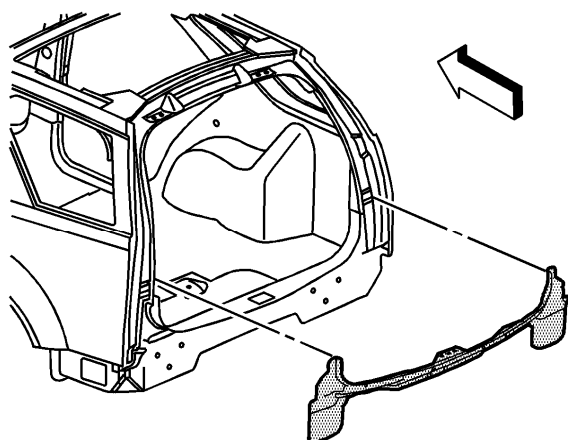

7. Remove the rear end panel.

## Installation Procedure

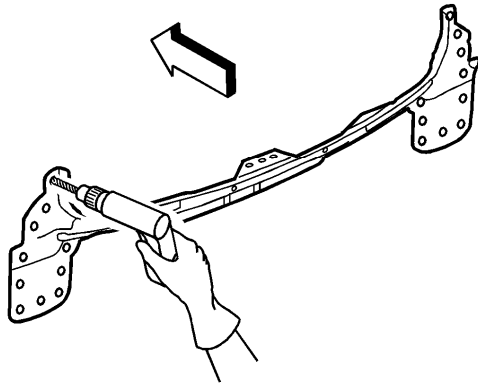

**Important:** If the location of the original plug weld holes can not be determined, place plug weld holes 40 mm (1½ in) apart.

1. Drill 8 mm (5/16 in) plug weld holes in the service part as necessary in the locations noted from the original panel.
2. Prepare all mating surfaces as necessary.
3. Apply GM-approved Weld-Thru Coating or equivalent to all mating surfaces. Refer to [Anti-Corrosion Treatment and Repair](#).

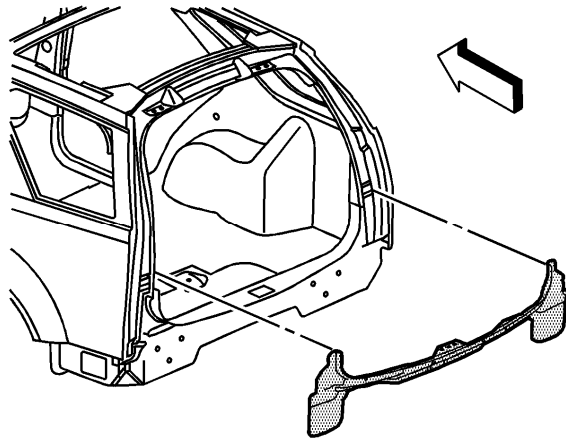

4. Position the rear end panel.

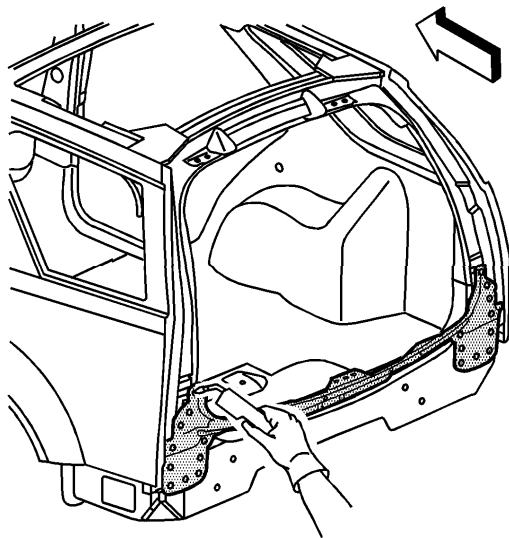

5. Plug weld accordingly.
6. Clean and prepare all of the welded surfaces.
7. Install all of the related panels and components.
8. Apply the sealers and anti-corrosion materials to the repair area, as necessary. Refer to [Anti-Corrosion Treatment and Repair](#) in Paint and Coatings.
9. Paint the repaired area. Refer to [Basecoat/Clearcoat Paint Systems](#) in Paint and Coatings.
10. Connect the negative battery cable. Refer to [Battery Negative Cable Disconnection and Connection](#) in Engine Electrical.
11. Enable the SIR system. Refer to [SIR Disabling and Enabling](#) in SIR.