

Rear Wheelhouse Replacement

Removal Procedure

Caution: Refer to [Approved Equipment for Collision Repair Caution](#) in Cautions and Notices.

1. Disable the SIR system. Refer to [SIR Disabling and Enabling](#) in SIR.
2. Disconnect the negative battery cable. Refer to [Battery Negative Cable Disconnection and Connection](#) in Engine Electrical.

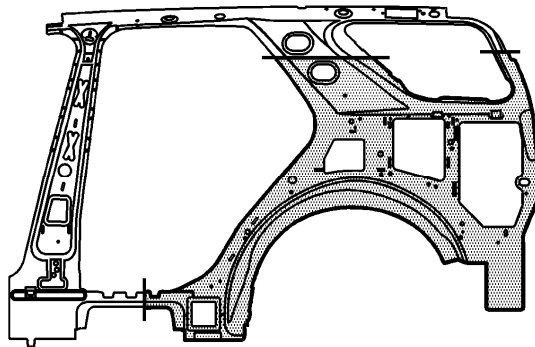

Caution: Sectioning should be performed only in the recommended areas. Failure to do so may compromise the structural integrity of the vehicle and cause personal injury if the vehicle is in a collision.

3. Remove all related panels and components.
4. Repair as much of the damage as possible.
5. Remove the sealers and anti-corrosion materials from the repair area, as necessary. Refer to [Anti-Corrosion Treatment and Repair](#) in Paint and Coatings.

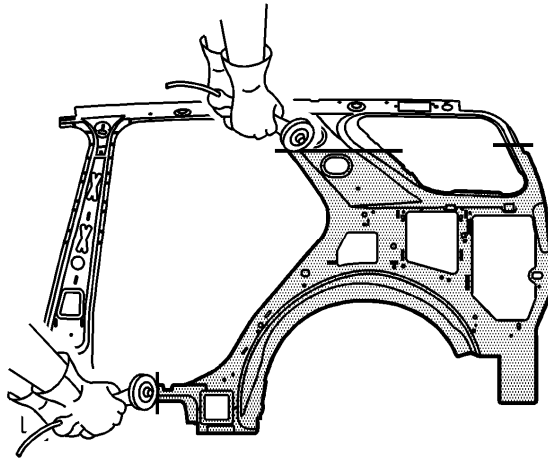

Important: Do not damage any inner panels or reinforcements.

6. Apply a piece of 20 mm (3/4 in) tape (2) along the area indicated horizontally long the rail.
7. In the rocker panel area, mark a vertical line in the marked area.
8. Cut the panel where sectioning is to be performed.

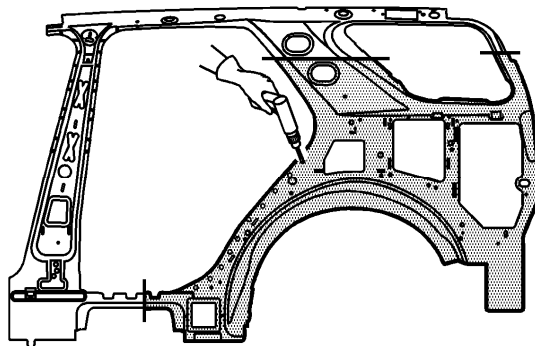

Important: Note the number and location of the factory welds for installation of the quarter panel.

9. Locate, mark, and drill out all the necessary factory welds.

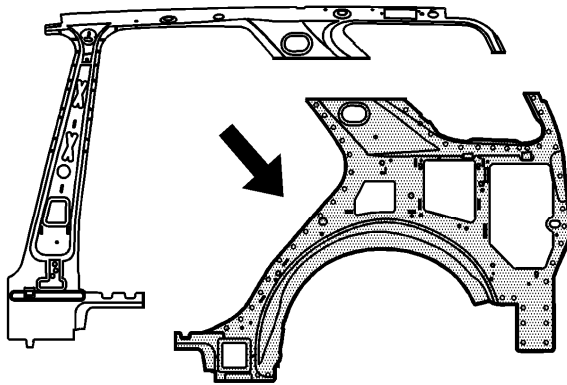

10. Remove the damaged wheelhouse section.

Installation Procedure

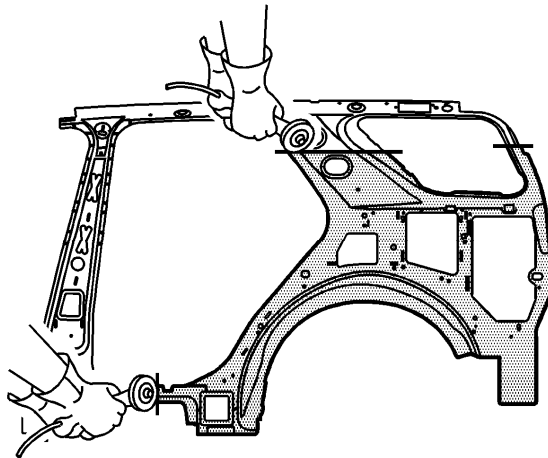

1. Cut the service part in the corresponding locations to the sectioning cuts. Allow for a 25 mm (1 in) overlap to the vehicle.

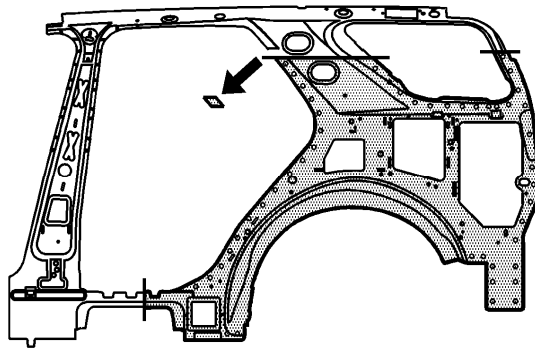

2. In the door opening location notch as shown.

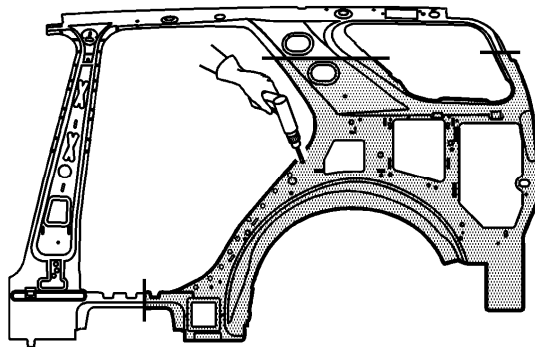

3. Drill 8 mm (5/16 in) plug weld holes along the sectioning cut on the original reinforcement. Locate these holes 13 mm (1/2 in) from the edge and spaced 40 mm (1 1/2 in) apart.

Important: If the location of the original plug weld holes can not be determined, place plug weld holes 40 mm (1 1/2 in) apart.

4. Drill 8 mm (5/16 in) plug weld holes in the service reinforcement as necessary in the locations noted from the original panel.
5. Prepare all mating surfaces as necessary.

6. Apply GM-approved Weld-Thru Coating or equivalent to all mating surfaces.
Refer to [Anti-Corrosion Treatment and Repair](#).

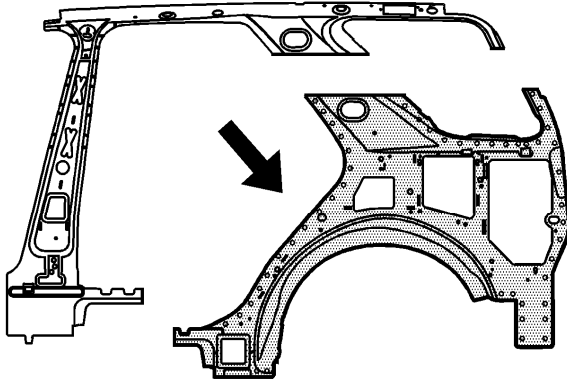

7. Align the service part on the vehicle using 3-dimensional measuring equipment.

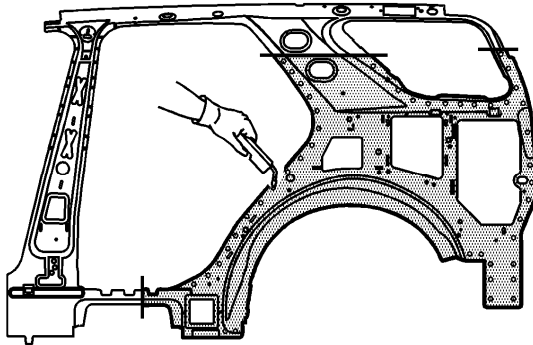

8. Plug weld accordingly.

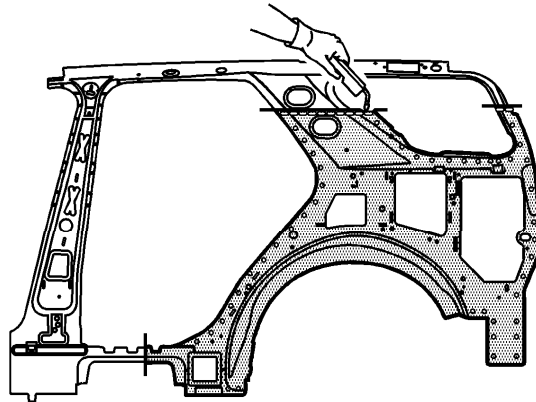

9. To create a solid weld with minimum heat distortion, make 25 mm (1 in) stitch welds along the seam with 25 mm (1 in) gaps between them. Go back and complete the stitch weld.
10. Clean and prepare all of the welded surfaces.
11. Apply the sealers and anti-corrosion materials to the repair area, as necessary. Refer to [Anti-Corrosion Treatment and Repair](#) in Paint and Coatings.
12. Paint the repaired area. Refer to [Basecoat/Clearcoat Paint Systems](#) in Paint and Coatings.
13. Install all of the related panels and components.
14. Connect the negative battery cable. Refer to [Battery Negative Cable Disconnection and Connection](#) in Engine Electrical.
15. Enable the SIR system. Refer to [SIR Disabling and Enabling](#) in SIR.