

Roof Outer Replacement

Description

This repair procedure gives you the option of using an installation procedure for either metal-inert gas (MIG) welding or adhesive bonding. The choice of installation depends on the type of application requirements. The adhesive bonding procedure may also require MIG welding in some areas of the repair.

Removal Procedure

Caution: Refer to [Approved Equipment for Collision Repair Caution](#) in Cautions and Notices.

Important: Before beginning the repair, refer to [Metal Panel Bonding](#) for proper adhesive preparations and general information.

1. Disable the SIR system. Refer to [SIR Disabling and Enabling Zones](#) in SIR.
2. Disconnect the negative battery cable. Refer to [Battery Negative Cable Disconnect/Connect Procedure](#) in Engine Electrical.

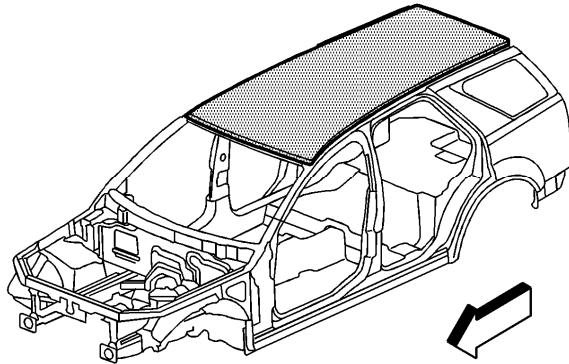

3. Remove all related panels and components.
4. Repair as much of the damage as possible to factory specifications. Refer to [Dimensions - Body](#).

Caution: Refer to [Foam Sound Deadeners Caution](#) in Cautions and Notices.

5. Note the location and remove the sealers and anti-corrosion materials from the repair area, as necessary. Refer to [Anti-Corrosion Treatment and Repair](#) in Paint and Coatings.
6. Remove the windshield. Refer to [Windshield Replacement](#) in Stationary Windows.

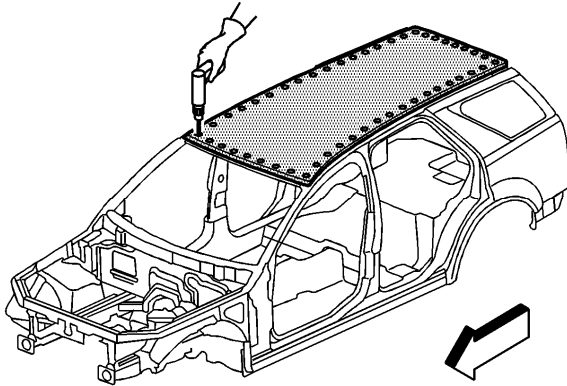

7. Locate and drill out all factory welds. Note the number and location of welds for installation of the roof panel.

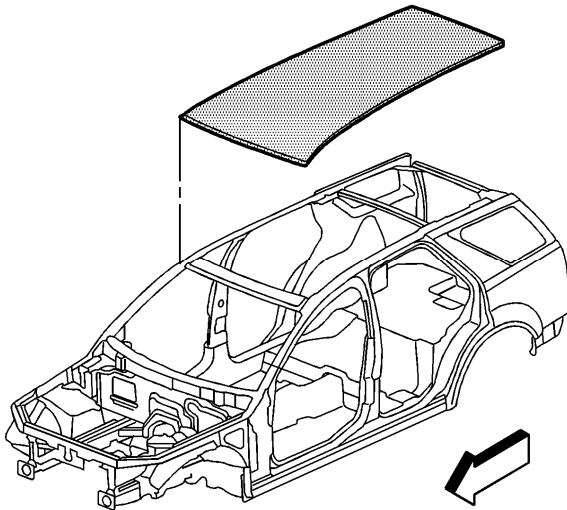

8. With an assistant remove the roof panel.

Installation Procedure (Metal-Inert Gas (MIG) Welding)

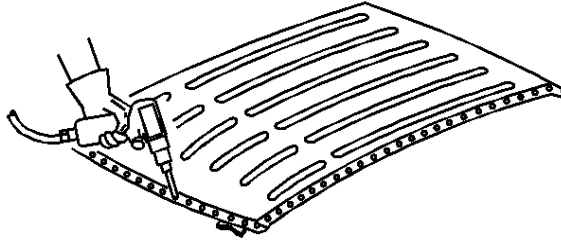

1. If you are MIG welding the roof panel, perform the following steps:
 - A. Drill 8 mm (5/16 in) plug weld holes as necessary in locations noted from the original panel.

Important: If the location of the original plug weld holes can not be determined, or if structural weld-thru adhesive is present, space the plug weld holes every 40 mm (1½ in) apart.

- B. Prepare all mating surfaces, as necessary.
- C. Apply GM-approved Weld-Thru Coating or equivalent to all mating surfaces. Refer to [Anti-Corrosion Treatment and Repair](#).

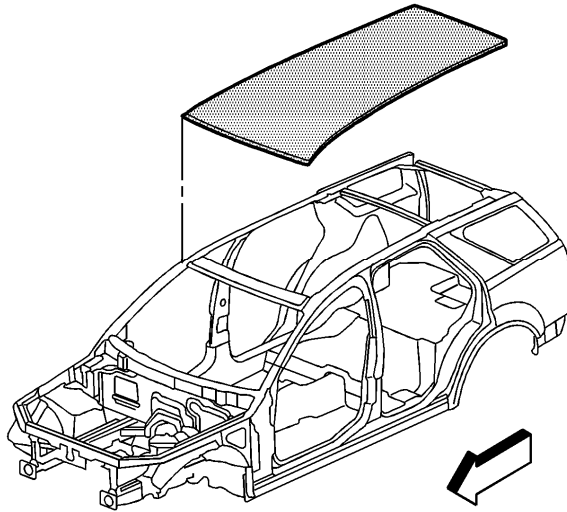

2. With the aid of an assistant, position the roof panel to the body.

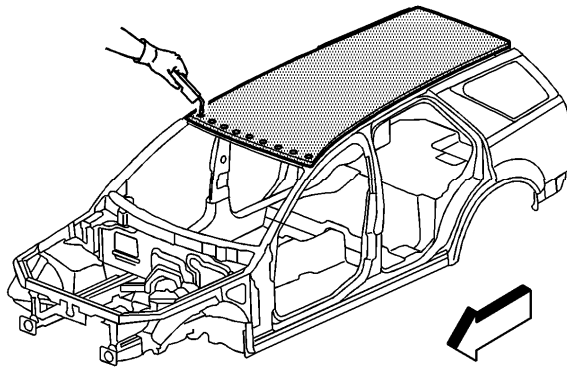

3. Plug weld accordingly.
4. Clean and prepare all welded surfaces.
5. Apply the sealers and anti-corrosion materials to the repair area, as necessary. Refer to [Anti-Corrosion Treatment and Repair](#) in Paint and Coatings.
6. Paint the repair area. Refer to [Basecoat/Clearcoat Paint Systems](#) in Paint and Coatings.
7. Install the windshield. Refer to [Windshield Replacement](#) in Stationary Windows.
8. Install all related panels and components.

9. Connect the negative battery cable. Refer to [Battery Negative Cable Disconnect/Connect Procedure](#) in Engine Electrical.
10. Enable the SIR system. Refer to [SIR Disabling and Enabling Zones](#) in SIR.

Installation Procedure (Adhesive Bonding)

1. Grind the surface of the body mating flanges to bare steel.

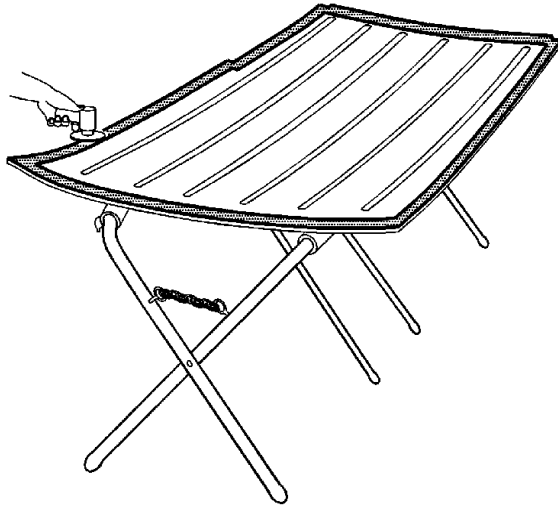

2. Grind the roof panel mating flanges to remove the E-coating. Take care not to damage the corners or thin the metal during the grinding operation.
3. Clean the mating surfaces.

Important: The adhesive has a 40 to 50 minute working time. Do not allow the adhesive to totally cure off the vehicle, as proper alignment of the roof panel to the body will be difficult.

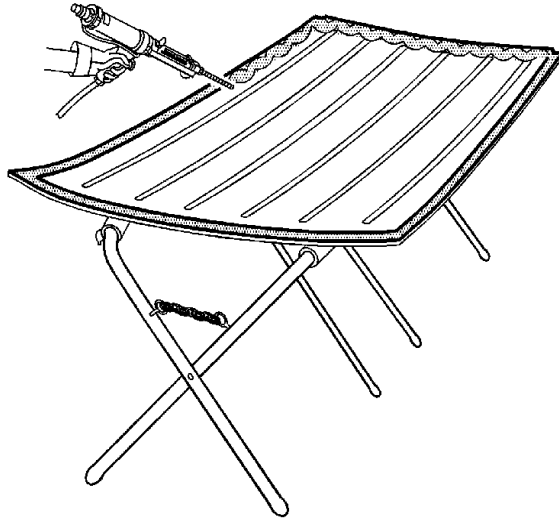

4. Apply a 3-6 mm (1/8-1/4 in) bead of metal panel bonding adhesive GM P/N 12378566/7 (Canadian P/N 88901674/5) or equivalent, to both of the mating surfaces.



5. Using a small acid brush, spread a coat of adhesive to cover all the bare metal surfaces to ensure corrosion protection.

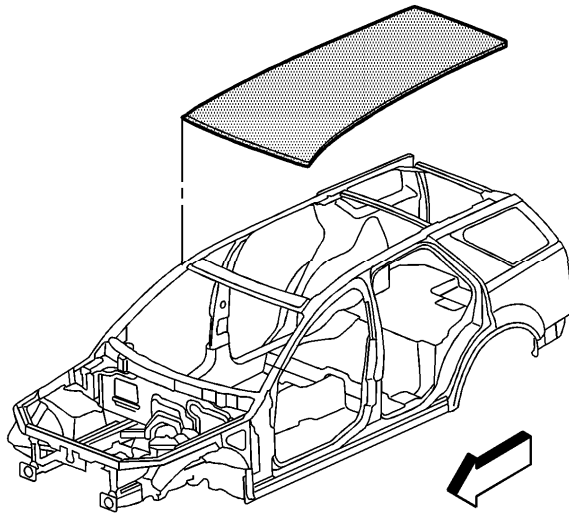

Important: DO NOT pull the panels apart after joined together. Slide the panels against each other to realign the panels.

6. Install the roof panel to the body with 2 or more assistants.

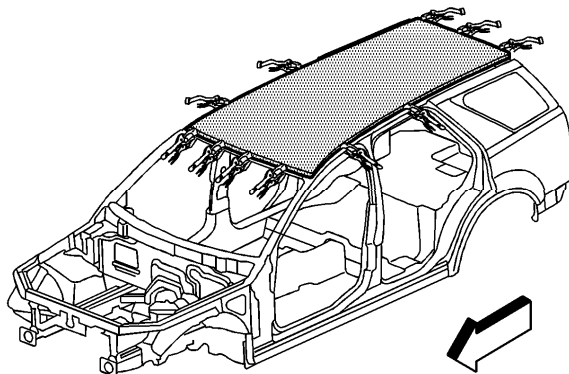

7. Clamp the roof panel into position, as required.
8. Using lacquer thinner remove the excess adhesive from the roof panel area.

9. Apply the sealers and anti-corrosion materials to the repair area, as necessary. Refer to [Anti-Corrosion Treatment and Repair](#) in Paint and Coatings.
10. Paint the repair area. Refer to [Basecoat/Clearcoat Paint Systems](#) in Paint and Coatings.
11. Install the windshield. Refer to [Windshield Replacement](#) in Stationary Windows.
12. Install all related panels and components.
13. Connect the negative battery cable. Refer to [Battery Negative Cable Disconnect/Connect Procedure](#) in Engine Electrical.
14. Enable the SIR system. Refer to [SIR Disabling and Enabling Zones](#) in SIR.