

# Door Outer Panel Replacement

## Removal Procedure

**Caution:** Refer to [Approved Equipment for Collision Repair Caution](#) in Cautions and Notices.

**Important:** Before beginning the repair, refer to [Metal Panel Bonding](#) for proper adhesive applicator preparations and general information.

1. Disconnect the negative battery cable. Refer to [Battery Negative Cable Disconnection and Connection](#) .
2. Disable the SIR system. Refer to [SIR Disabling and Enabling](#) .
3. Remove the door from the vehicle. Refer to [Front Side Door Replacement](#) or [Rear Side Door Replacement](#) .
4. Remove the outer door handle. Refer to [Front Side Door Outside Handle Replacement](#) .
5. Remove the outside rearview mirror. Refer to [Mirror Replacement](#) .

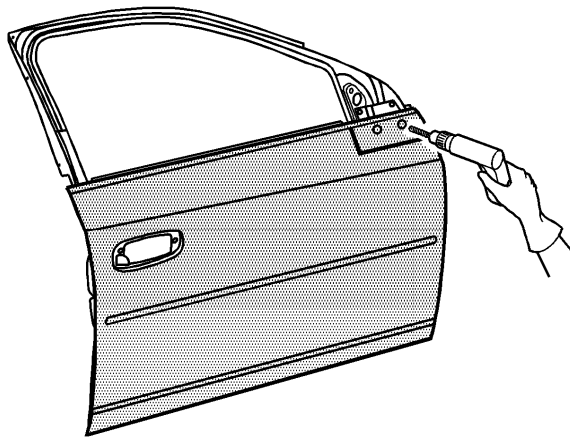

6. Cut a hole in the outer door panel to access the welds on the belt reinforcement.
7. Drill out the spot welds that attach the outer belt reinforcement to the outer door panel flange.

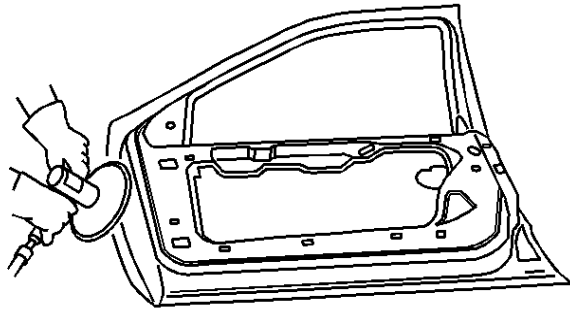

8. Grind the edges of the door outer panel to separate the outer door panel from the door shell.

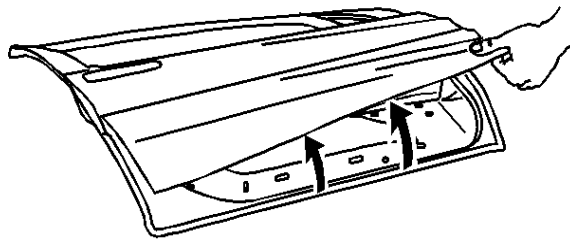

9. Remove the outer door panel.
10. Remove the sealers and anti-corrosion materials from the repair area, as necessary.  
Refer to [Anti-Corrosion Treatment and Repair](#) .

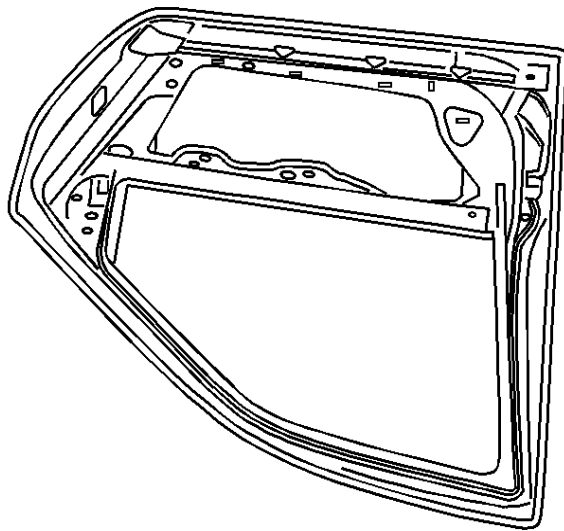

11. Straighten the edges of the door shell.

### Installation Procedure

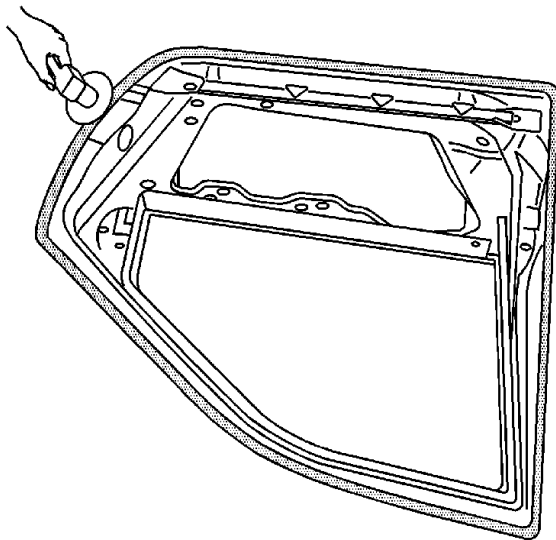

1. Grind the surface of the door shell mating flanges to bare steel.

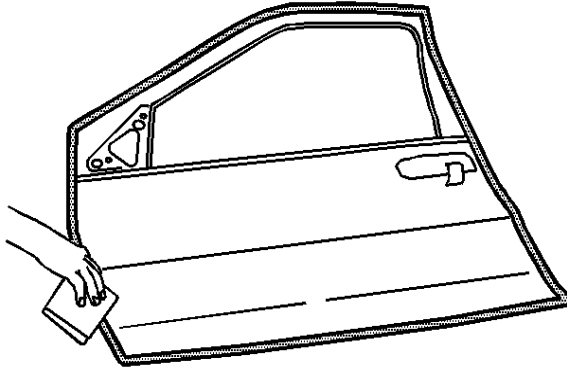

2. Scuff the opposing mating surfaces of the door outer panel to remove the gloss of the E-Coat.

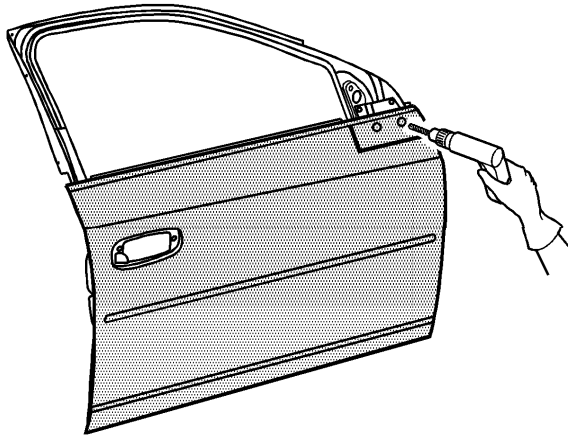

3. Drill 8 mm (5/16 in) plug weld holes, as necessary, in locations noted from the original panel.

**Important:** If the location of the original plug weld holes cannot be determined, or if structural weld-thru adhesive is present, space the plug weld holes every 40 mm (1½ in) apart.

4. Prepare all mating surfaces, as necessary.

5. Apply GM-approved Weld-Thru Coating or equivalent to all mating surfaces. Refer to [Anti-Corrosion Treatment and Repair](#) .

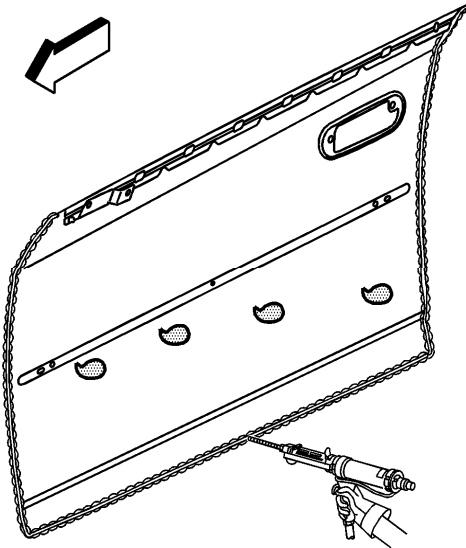

**Important:** The adhesive has a 40-50 minute working time. Do not allow the door to totally cure off the vehicle, as proper alignment of the door outer panel to the door shell will be difficult.

6. Apply a 3-6 mm (1/8 to 1/4 in) bead of metal panel bonding adhesive GM P/N 12378566/7 (Canadian P/N 88901674/5), or equivalent, to both of the mating surfaces.
7. Using a small acid brush, spread a coat of adhesive to cover all the bare metal surfaces to ensure corrosion protection.
8. Apply a 9-13 mm (3/8 to 1/2 in) bead of metal panel bonding adhesive GM P/N 12378566/7 (Canadian P/N 88901674/5), or equivalent, to the service part mating surfaces.

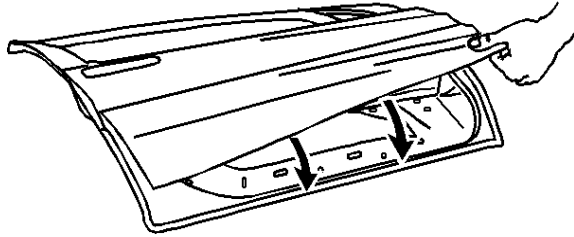

**Important:** DO NOT pull the panels apart after being joined together. Slide the panels against each other to realign the panels.

9. Install the door outer panel to the door shell.
10. Clamp the door outer panel into position, as required.

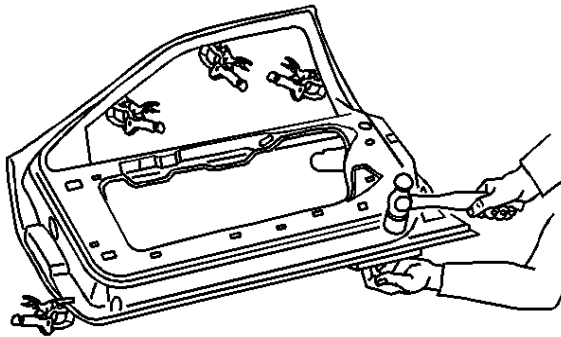

11. Using a hammer re-hem the hem flanges around the door shell.

Continue to hammer in stages along the hem flanges.

12. Using lacquer thinner remove the excess adhesive from the door panel area.

13. Install the door to the vehicle, then check the door outer panel for proper alignment. Adjust the alignment, as required. Refer to [Door Adjustment](#) .
14. Remove the door from the vehicle to complete the repair.

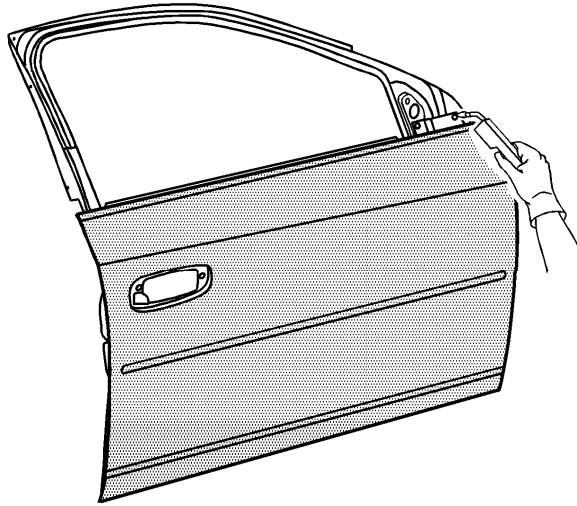

15. Using metal-inert gas (MIG), weld the door outer panel to the door frame in the locations noted at the upper door frame.
16. Clean and prepare all welded surfaces.

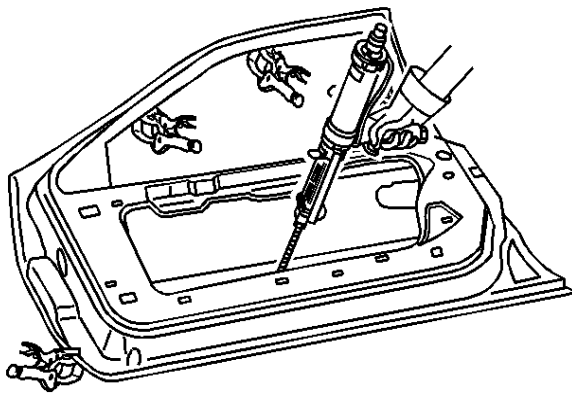

17. Apply Fusor super flexible anti-flutter foam - fast set, Fusor P/N 121/124, or equivalent, in 4-5 evenly spaced locations between the door outer panel and the inner safety beam.
18. Apply sealers and anti-corrosion materials to the repair area, as necessary. Refer to [Anti-Corrosion Treatment and Repair](#) .
19. Paint the repaired area. Refer to [Basecoat/Clearcoat Paint Systems](#) .

20. Install the door to the vehicle. Refer to [Front Side Door Replacement](#) or [Rear Side Door Replacement](#) .

Inspect the door outer panel for proper alignment and adjust the alignment, as required. Refer to [Door Adjustment](#) .

21. Install the outer door handle. Refer to [Front Side Door Outside Handle Replacement](#) .
22. Install the outside rearview mirror. Refer to [Mirror Replacement](#) .
23. Enable the SIR system. Refer to [SIR Disabling and Enabling](#) .
24. Connect the negative battery cable. Refer to [Battery Negative Cable Disconnection and Connection](#) .