

Front Hinge Pillar Sectioning

Removal Procedure

Caution: Refer to [Approved Equipment for Collision Repair Caution](#) in Cautions and Notices.

Caution: Sectioning should be performed only in the recommended areas. Failure to do so may compromise the structural integrity of the vehicle and cause personal injury if the vehicle is in a collision.

Important: When replacing panels that involve servicing of stationary glass, refer to service bulletin 43-10-45 before performing any priming or refinishing.

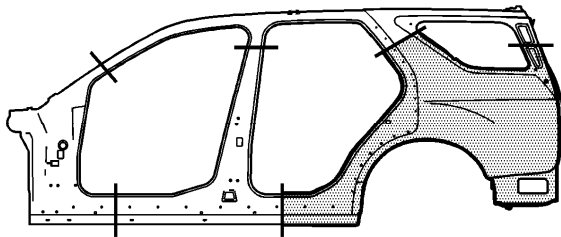

The full body-side outer panel comes as a complete assembly and can be replaced at factory seams after the removal of the fixed glass and roof. Any one of these service procedures can be performed separately or in any combination, depending upon the extent of damage to the vehicle. Sectioning must take place in specified areas only.

1. Disable the SIR system. Refer to [SIR Disabling and Enabling](#) .

2. Disconnect the negative battery cable. Refer to [Battery Negative Cable Disconnection and Connection](#) .
3. Remove all related panels and components.
4. Repair as much of the damage as possible .

Caution: Foam sound deadeners must be removed from areas within 152.4 mm (6 in) of where flame is to be used for body repairs. When reinstalling foam sound deadeners, avoid inhaling fumes as bodily injury may result.

5. Remove sound deadeners as necessary and note their location.
6. Remove the sealers and anti-corrosion materials from the repair area, as necessary. Refer to [Anti-Corrosion Treatment and Repair](#) .

Important: Do not damage any inner panels or reinforcements.

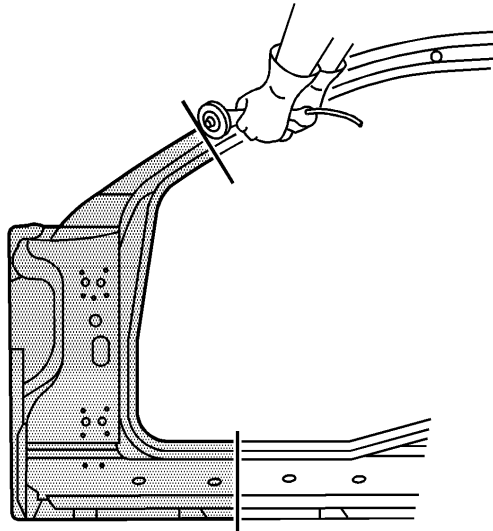

7. Cut the panel where sectioning is to be performed.

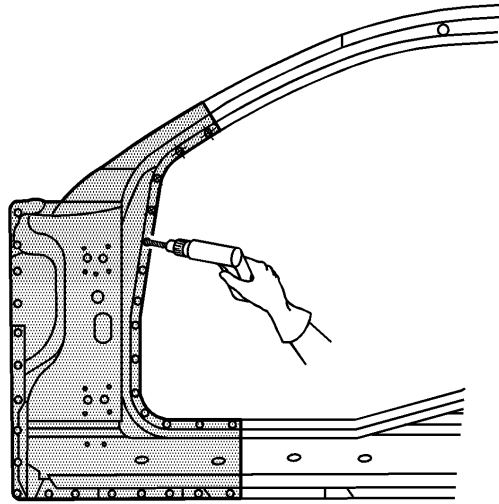

Important: Note the number and location of the factory welds for installation of the hinge pillar.

8. Locate and drill out all factory welds. Note the number and location of welds for installation of the service part.

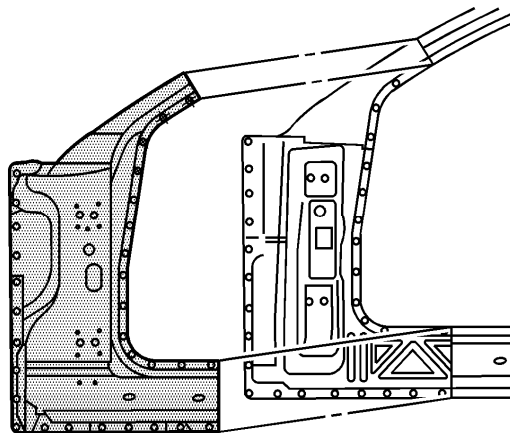

9. Remove the damaged hinge pillar.

Installation Procedure

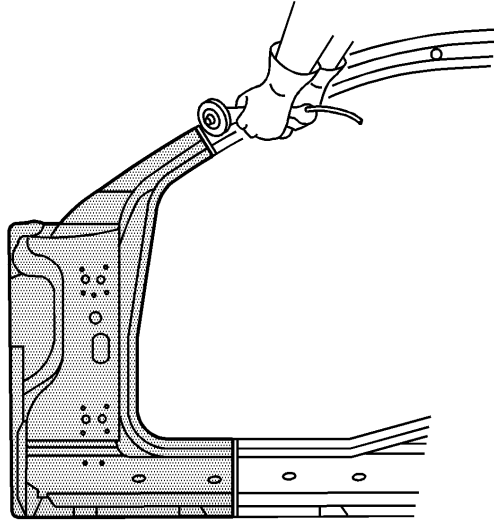

1. Cut the outer front hinge pillar in corresponding locations to fit the remaining original panel. The sectioning joint should be trimmed to allow a gap of $1\frac{1}{2}$ times the metal thickness at the sectioning joint.

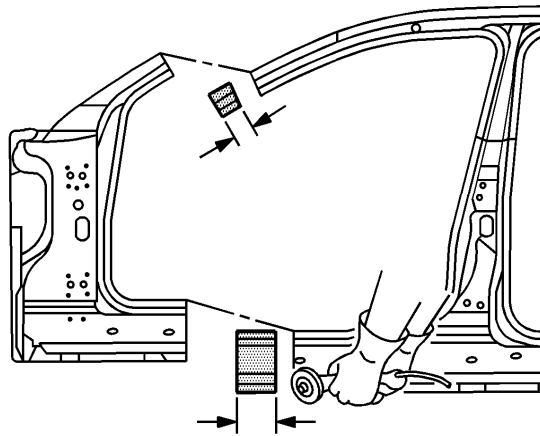

2. Create a 50 mm (2 in) backing plate from the unused portion of the service part for the windshield area. Create a 100 mm (4 in) backing plate from the unused portion of the service part for the rocker area. Trim the backing plates as necessary to fit behind the sectioning joint.

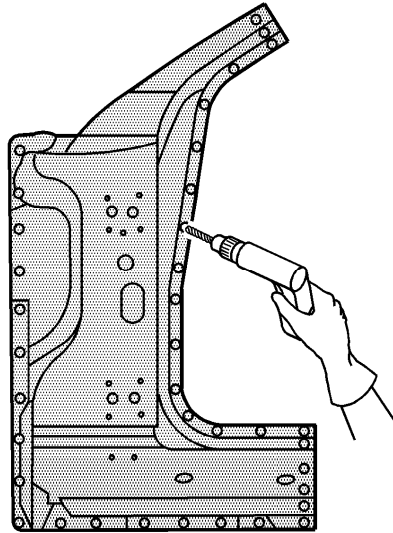

Important: If the location of the original plug weld holes can not be determined, place plug weld holes 40 mm (1½ in) apart.

3. Drill 8 mm (5/16 in) plug weld holes in the service part as necessary in the locations noted from the original panel and along the sectioning cut.
4. Prepare all mating surfaces as necessary.
5. Apply GM-approved Weld-Thru Coating or equivalent to all mating surfaces. Refer to [Anti-Corrosion Treatment and Repair](#) .

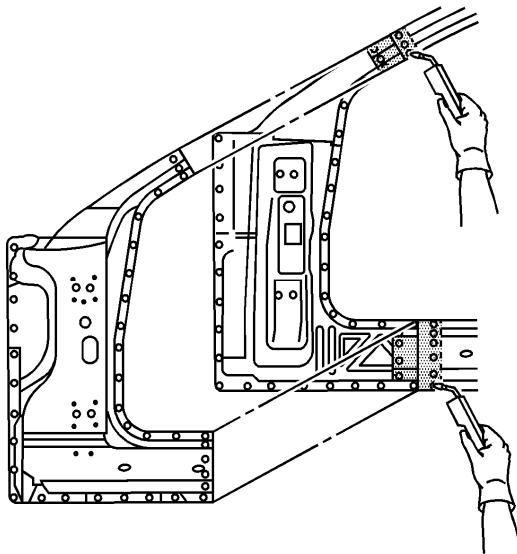

6. Fit the backing plates halfway into the sectioning joints, clamp in place and plug weld to the vehicle.

7. Align outer front pillar using 3-dimensional measuring equipment.

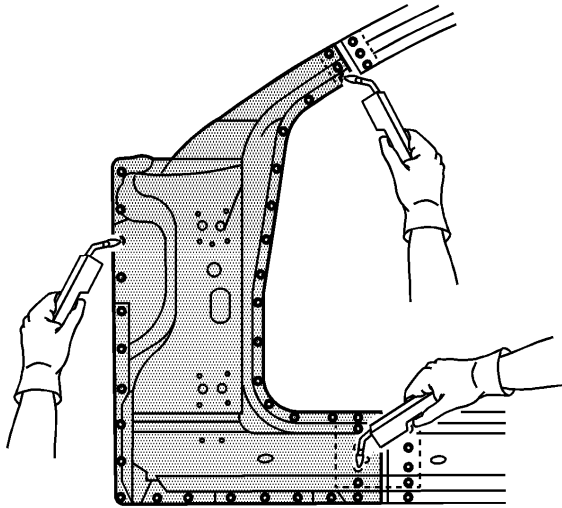

8. Plug weld accordingly.

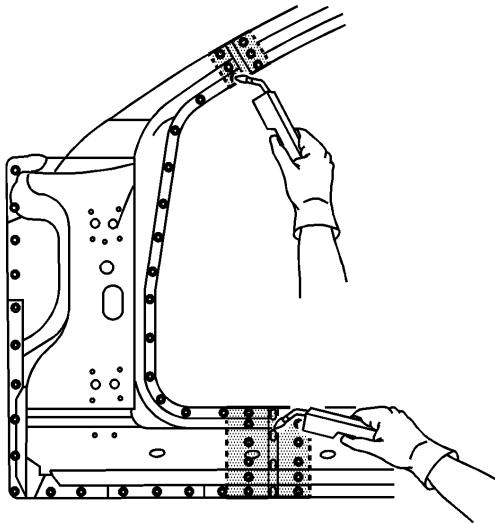

9. To create a solid weld with minimum heat distortion, make a 25 mm (1 in) stitch weld along the seam with 25 mm (1 in) gaps between them. Go back and complete the stitch weld.
10. Clean and prepare all of the welded surfaces.
11. Apply the sealers and anti-corrosion materials to the repair area, as necessary.
Refer to [Anti-Corrosion Treatment and Repair](#) .
12. Paint the repaired area. Refer to [Basecoat/Clearcoat Paint Systems](#) .
13. Install all of the related panels and components.
14. Connect the negative battery cable. Refer to [Battery Negative Cable Disconnection and Connection](#) .
15. Enable the SIR system. Refer to [SIR Disabling and Enabling](#) .