

Lower Rail Replacement

Removal Procedure

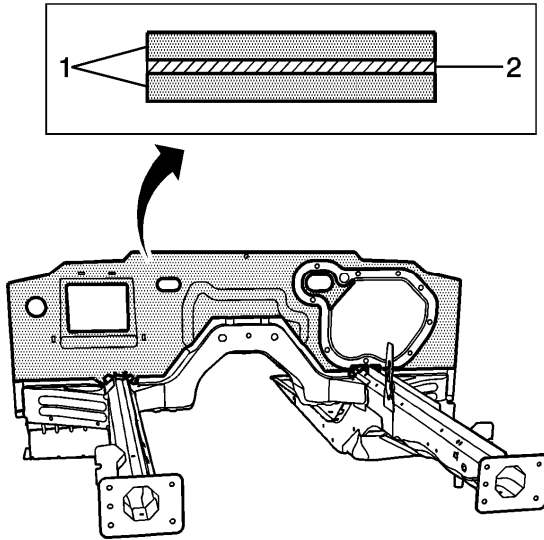

The front of the dash panel is formed from laminated steel. This steel is constructed by bonding 2 pieces of cold rolled steel (1) with a viscoelastic layer of adhesive (2). Metal inert gas (MIG) welding laminated steel does not meet GM Corporate standards for structural integrity. As an alternative, all factory welds will be replaced by using the rivet and adhesive bond method described in the installation portion of this procedure. The rivet and adhesive bond method must only be used in the areas as described in this procedure.

Important: Failure to follow this procedure will compromise the structural integrity of the vehicle.

Caution: Refer to [Approved Equipment for Collision Repair Caution](#) in Cautions and Notices.

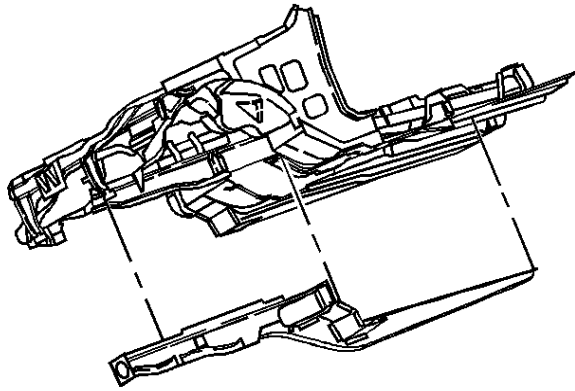

Caution: Foam sound deadeners must be removed from areas within 152.4 mm (6 in) of where flame is to be used for body repairs. When reinstalling foam sound deadeners, avoid inhaling fumes as bodily injury may result.

Important: The full rail service part comes with structural foam already installed. This part is replaced at factory seams.

1. Disable the SIR system. Refer to [SIR Disabling and Enabling](#) .
2. Disconnect the negative battery cable. Refer to [Battery Negative Cable Disconnection and Connection](#) .

Caution: Sectioning should be performed only in the recommended areas. Failure to do so may compromise the structural integrity of the vehicle and cause personal injury if the vehicle is in a collision.

3. Remove all related panels and components.
4. Repair as much of the damage as possible.
5. Remove the sealers and the anti-corrosion materials from the repair area, as necessary. Refer to [Anti-Corrosion Treatment and Repair](#) .

Important: Note the number and location of the factory welds for installation of the full rail service part.

6. Remove the front wheelhouse assembly. Refer to [Front Wheelhouse Replacement](#) .

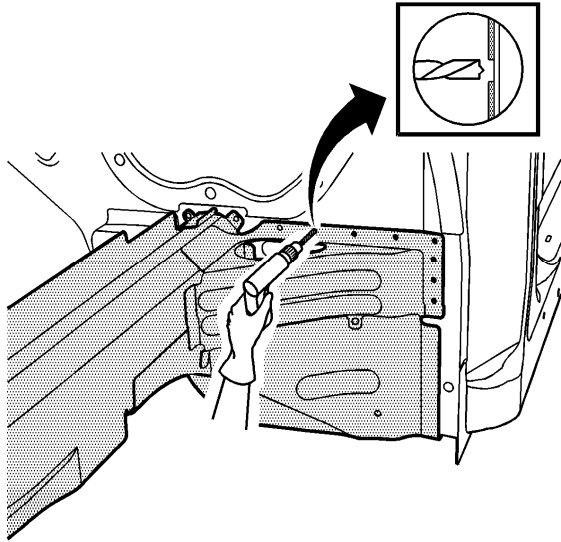

Important: Drill through the rail flange only. Do NOT drill into the dash panel or the inner reinforcements.

7. Using an 8-mm (5/16-in) spot weld remover, locate and drill out the factory welds on the weld flange connecting the lower rail to the dash panel.

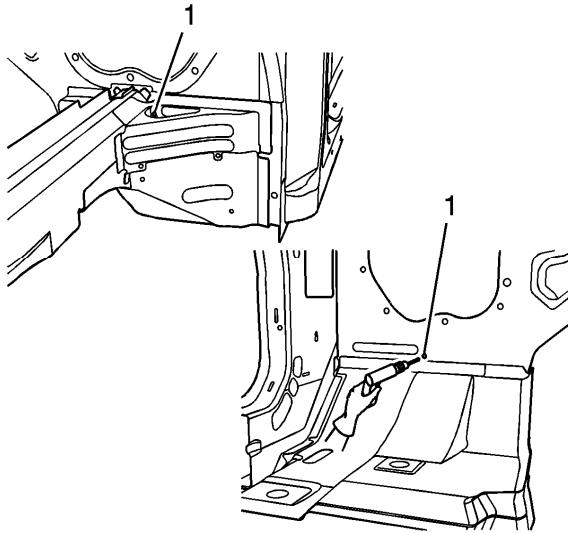

8. From the passenger compartment, locate and drill out the remaining factory weld (1) on the dash panel.

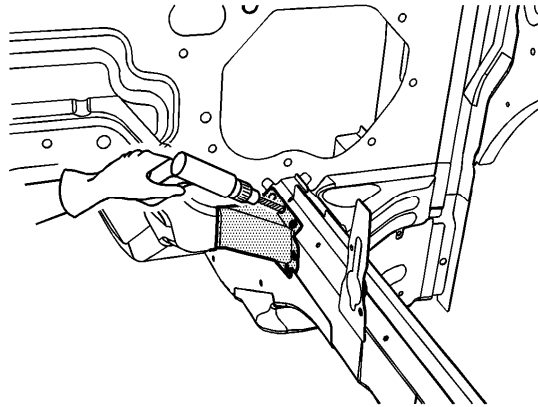

Important: Do NOT remove the rail inner reinforcement from the vehicle.

9. Locate and drill out the factory welds between the rail inner reinforcement and the rail.

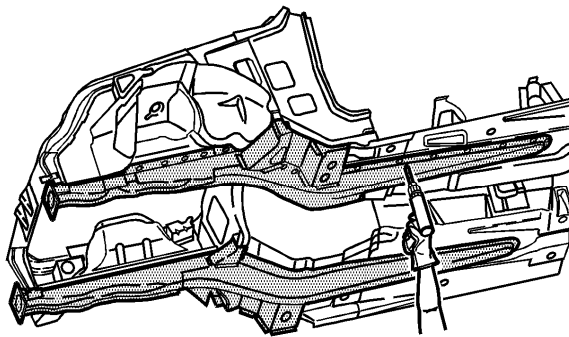

10. Locate and drill out the remaining factory welds on the rail.

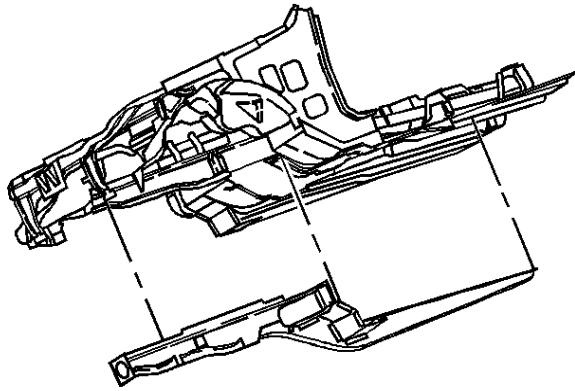

11. Remove the full rail.

Installation Procedure

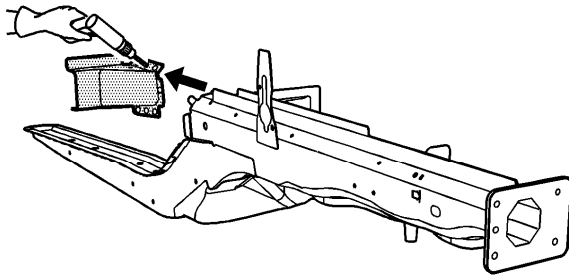

Important: Drill through the rail inner reinforcement flange only. Do NOT drill into the rail.

1. On the full rail service part, locate and drill out the factory welds between the rail inner reinforcement and the service rail.
2. Remove the rail inner reinforcement from the service rail.

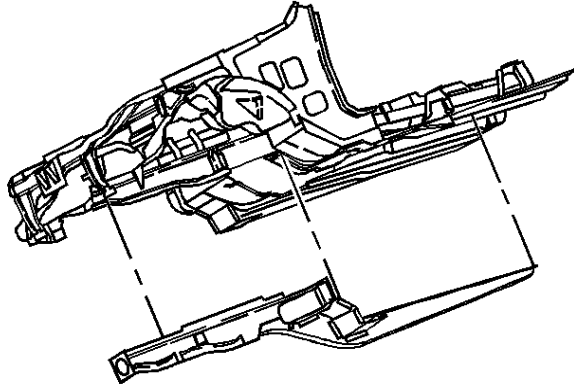

3. Position the service rail to the vehicle using three-dimensional measuring equipment.
4. Clamp the rail in place.

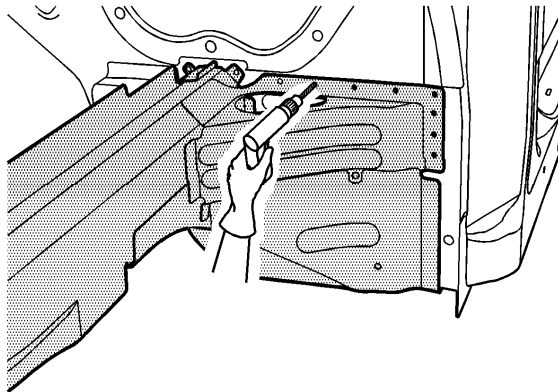

5. Using a 7-mm (17/64-in) bit, drill the rivet attachment holes through the service rail and the dash panel in the exact locations as noted from the factory rail.

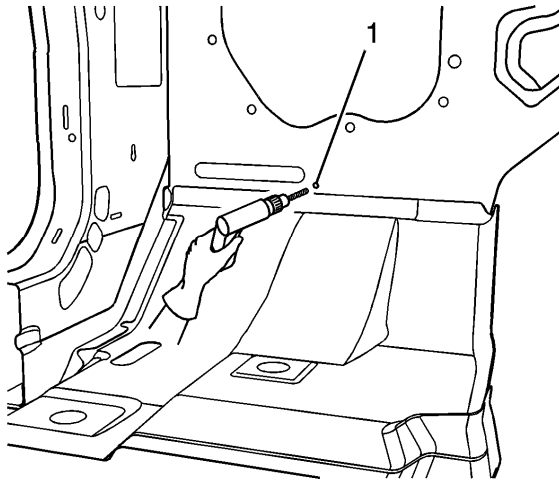

6. From the passenger compartment side of the vehicle, using a 7-mm (17/64-in) bit, drill the rivet attachment hole through the service rail using the existing 8-mm (5/16-in) hole in the dash panel as an alignment mark.
7. Remove the service rail.

Important: If the location of the original plug weld holes cannot be determined, space the plug weld holes every 40 mm (1.5 in) apart.

8. Drill 8-mm (5/16-in) plug weld holes in the service rail, as necessary, in the remaining locations noted from the original rail.
9. Prepare the plug weld mating surfaces, as necessary.
10. Apply GM-approved Weld-Thru Coating or equivalent to all mating surfaces. Refer to [Anti-Corrosion Treatment and Repair](#) .

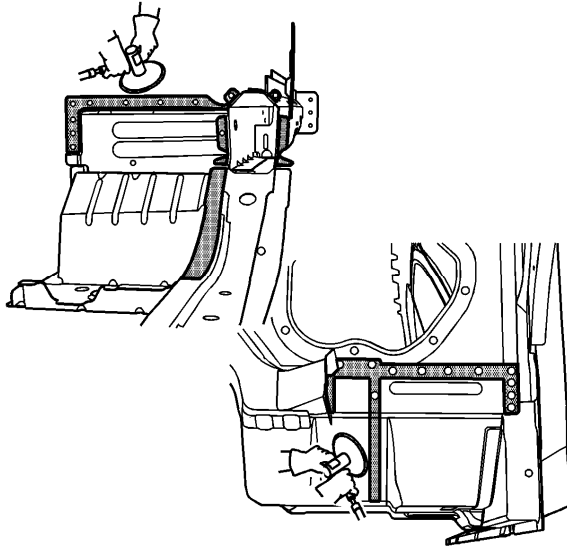

11. Prepare the bond mating areas by grinding the body mating and the service part flanges to bare steel. Do NOT damage the corners or thin the metal during the grinding process.
12. Clean the mating surfaces.

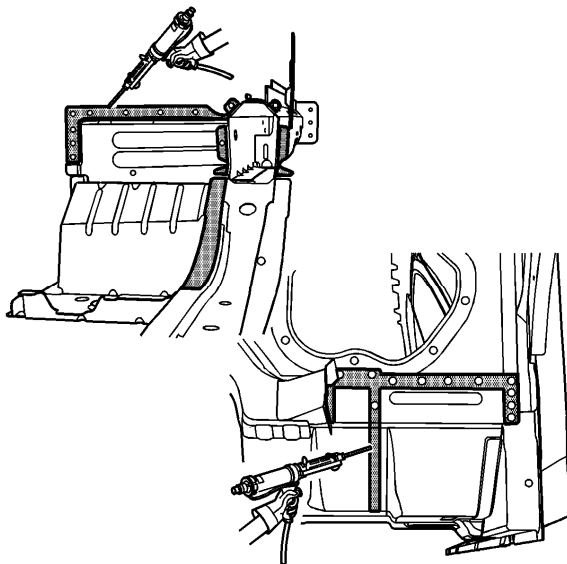

Important: The adhesive has a 40-50 minute working time. Do NOT allow the adhesive to cure prior to installing the service rail.

13. Apply a 3-6 mm (1/8 to 1/4 in) bead of metal panel bonding adhesive GM P/N 12378567 (Canadian P/N 88901675) or equivalent to both of the mating surfaces.

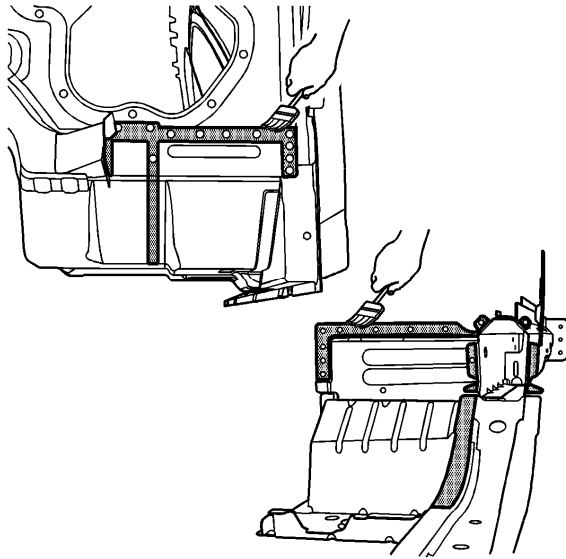

14. Using a small acid brush, spread a coat of adhesive to both of the mating surfaces. Cover all of the bare metal to ensure corrosion protection.

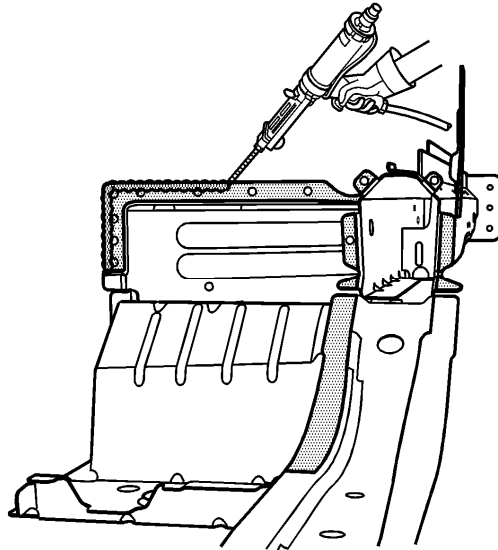

15. Apply a 3-6 mm (1/8 to 1/4 in) bead of metal panel bonding adhesive GM P/N 12378567 (Canadian P/N 88901675) or equivalent to the mating surface of the service rail.

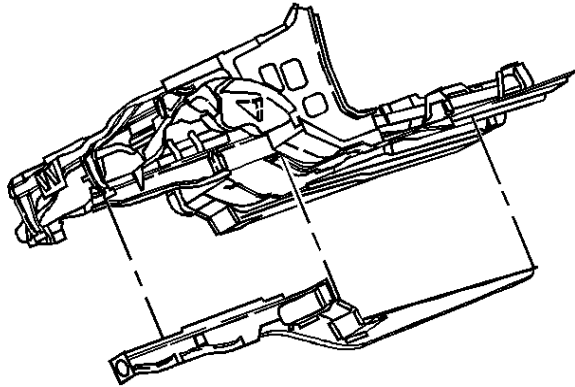

Important: Do NOT pull the rail off of the dash after adhesion. To align the parts, slide the rail against the front of the dash.

16. Position the service rail to the vehicle using three-dimensional measuring equipment.
17. Clamp the rail in place.

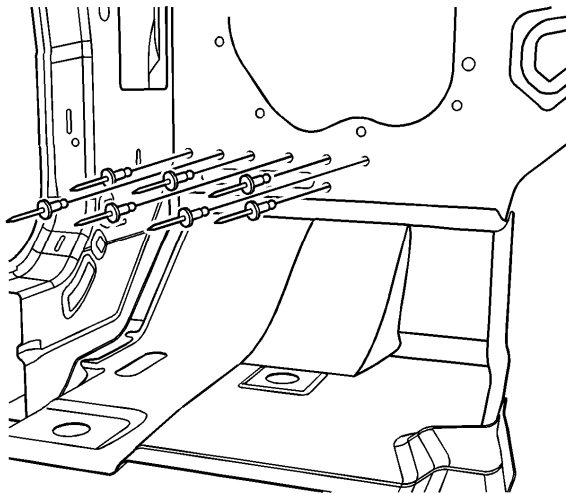

Important: Verify proper positioning of the service rail prior to riveting and welding.

18. Install the 9 mm (11/32 in) long rivets so that the rivet head contacts the passenger compartment side of the dash.

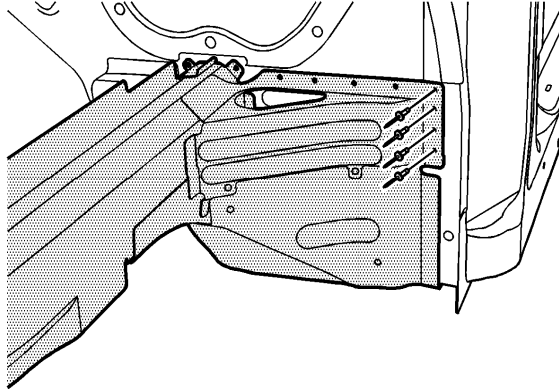

19. Install the 14 mm (17/32 in) long rivets so that the rivet head contacts the rail.
20. Remove the excess adhesive from the rail area.
21. Plug weld the remaining holes accordingly.
22. Clean and prepare all of the welded surfaces.
23. Install the front wheelhouse assembly. Refer to [Front Wheelhouse Replacement](#) .
24. Apply the sealers and anti-corrosion materials to the repaired area, as necessary.
Refer to [Anti-Corrosion Treatment and Repair](#) .
25. Paint the repaired area. Refer to [Basecoat/Clearcoat Paint Systems](#) .
26. Install all of the related panels and components.
27. Connect the negative battery cable. Refer to [Battery Negative Cable Disconnection and Connection](#) .
28. Enable the SIR system. Refer to [SIR Disabling and Enabling](#) .