

Lower Rail Sectioning

Removal Procedure

Caution: Refer to [Approved Equipment for Collision Repair Caution](#) in Cautions and Notices.

Important: If front rail damage is limited to 205 mm (8 in) from the front end, a pre-sleeved service section is available. This service section includes the front bumper mounting bracket.

1. Disable the SIR system. Refer to [SIR Disabling and Enabling](#) .
2. Disconnect the negative battery cable. Refer to [Battery Negative Cable Disconnection and Connection](#) .

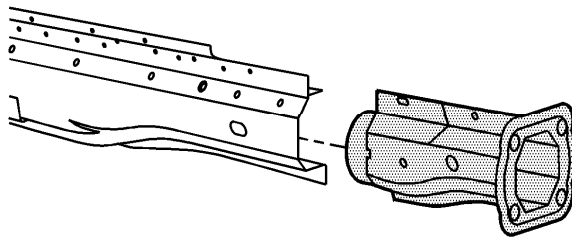

3. Remove all of the related panels and the components, including the left front wheelhouse mounting bracket to the rail.
4. Remove the sealers and anti-corrosion materials from the repair area, as necessary. Refer to [Anti-Corrosion Treatment and Repair](#) .

5. Repair as much as the damage as possible.
6. Locate the die marks on the inner and outer rail.

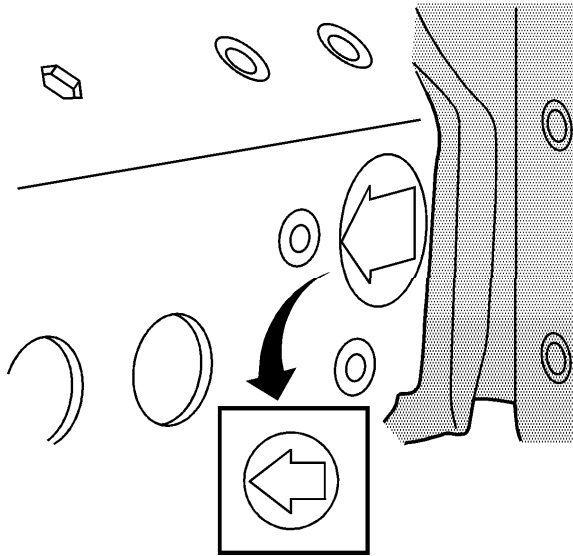

7. Locate the die marks on the front rail.

Important: Do not damage the rail behind the die marks.

8. Scribe a line 360 degrees around the frame rail at the die marks.
9. Cut at the marked location.
10. Remove the damaged component from the vehicle.

Installation Procedure

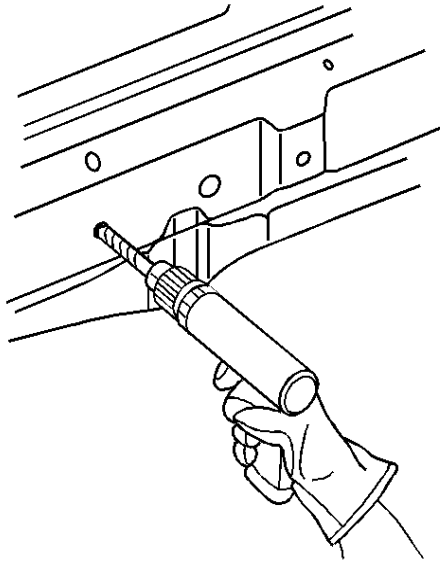

1. Drill 4 plug weld holes; 2 at the inside and 2 at the outside, 13 mm (1/2 in) from the cut line and 50 mm (2 in) apart on the existing frame rail.
2. Apply GM-approved Weld-Thru Coating or equivalent to all mating surfaces. Refer to [Anti-Corrosion Treatment and Repair](#) .

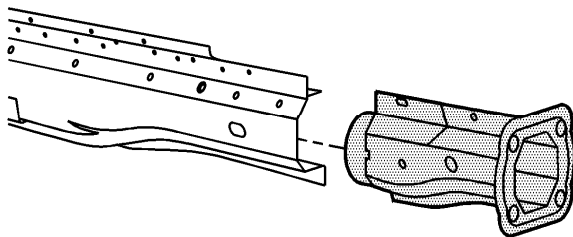

3. Install and position the replacement service section using 3-dimensional measuring.

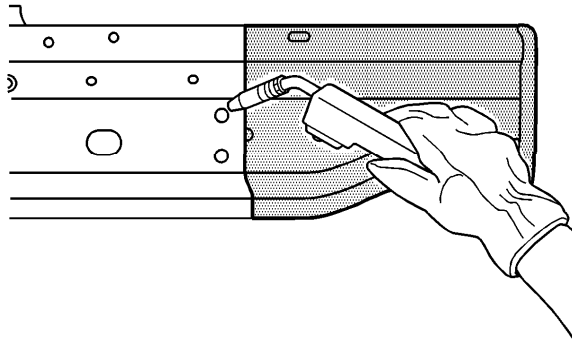

4. Tack weld the part into position at the initial plug weld holes.
5. Inspect the service part for proper dimensions using 3-dimensional measuring equipment.
6. Stitch weld along the entire sectioning joint. Make 25 mm (1 in) welds along the seam with 25 mm (1 in) gaps between.
7. Complete the stitch weld.
8. Clean and prepare the welded surfaces.
9. Position the tie bar mounting bracket. Weld the bracket in place.
10. Install all of the related panels and components.
11. Apply the sealers and anti-corrosion materials to the repair area, as necessary.
Refer to [Anti-Corrosion Treatment and Repair](#) .
12. Paint the repaired area. Refer to [Basecoat/Clearcoat Paint Systems](#) .
13. Enable the SIR system. Refer to [SIR Disabling and Enabling](#) .
14. Connect the negative battery cable. Refer to [Battery Negative Cable Disconnection and Connection](#) .