

Rear Rail Replacement

Removal Procedure

Caution: Refer to [Approved Equipment for Collision Repair Caution](#) in Cautions and Notices.

1. Disable the SIR system. Refer to [SIR Disabling and Enabling](#) .
2. Disconnect the negative battery cable. Refer to [Battery Negative Cable Disconnection and Connection](#) .

Important: The rear rails are available as complete assemblies. The rear rail section is also available separately.

Important: This procedure should be used if the damage is rearward of the factory joint between the front and rear rail components.

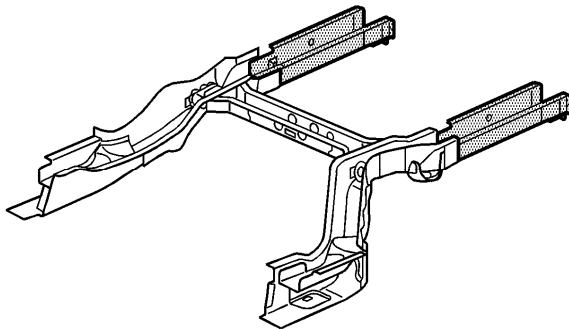

3. Remove all related panels and components.

Caution: Foam sound deadeners must be removed from areas within 152.4 mm (6 in) of where flame is to be used for body repairs. When

reinstalling foam sound deadeners, avoid inhaling fumes as bodily injury may result.

4. Remove and note the location of any sound deadening materials.
5. Remove and note the location of the sealers and anti-corrosion materials from the repair area, as necessary. Refer to [Anti-Corrosion Treatment and Repair](#) .
6. Repair as much of the damage as possible.

Important: Do not damage any inner panels or reinforcements.

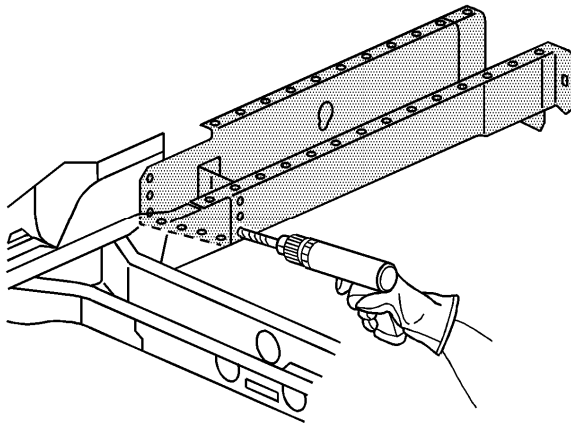

7. Locate, mark, and drill out all factory welds. Note the number and location of welds for installation of the service assembly.

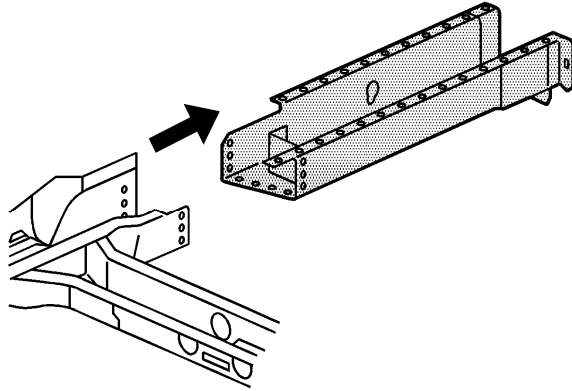

8. Remove the damaged rail section.

Installation Procedure

Important: This part has structural weld-thru adhesive in the joint areas. Replace this with additional spot welds at the attachment points. This can be accomplished by adding an additional weld between each factory weld in all areas.

Important: If the location of the original plug weld holes can not be determined, or if structural weld-thru adhesive is present, space the plug weld holes every 40 mm (1½ in).

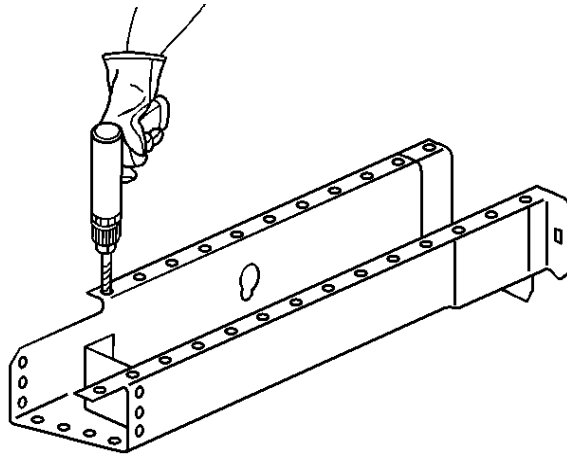

1. Drill 8 mm (5/16 in) plug weld holes in the service part, as necessary, in the locations noted from the original panel.
2. Prepare the mating surfaces, as necessary.
3. Apply GM-approved Weld-Thru Coating or equivalent to all mating surfaces. Refer to [Anti-Corrosion Treatment and Repair](#) .

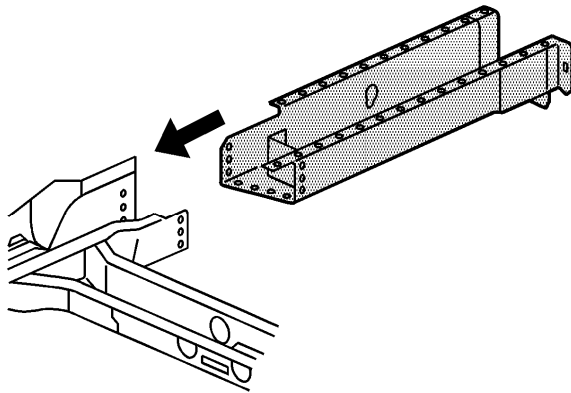

4. Position the rear rail service part. Verify the fit with 3-dimensional measuring equipment.

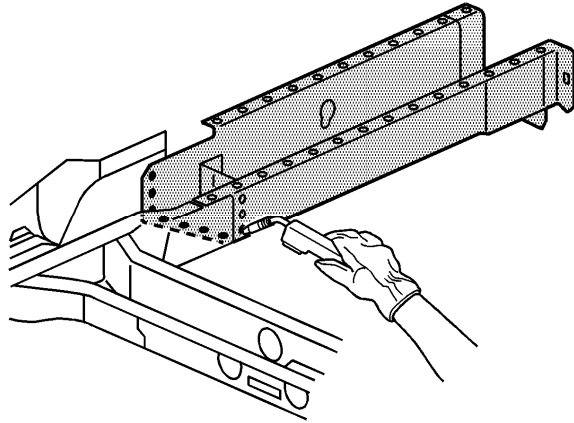

5. Plug weld accordingly.
6. Clean and prepare all welded surfaces.
7. Apply the sealers, and anti-corrosion materials to the repair area, as necessary.
Refer to [Anti-Corrosion Treatment and Repair](#) .
8. Paint the repaired area. Refer to [Basecoat/Clearcoat Paint Systems](#) .
9. Install all related panels and components.
10. Connect the negative battery cable. Refer to [Battery Negative Cable Disconnection and Connection](#) .
11. Enable the SIR system. Refer to [SIR Disabling and Enabling](#) .