

Tie Bar Replacement

Removal Procedure

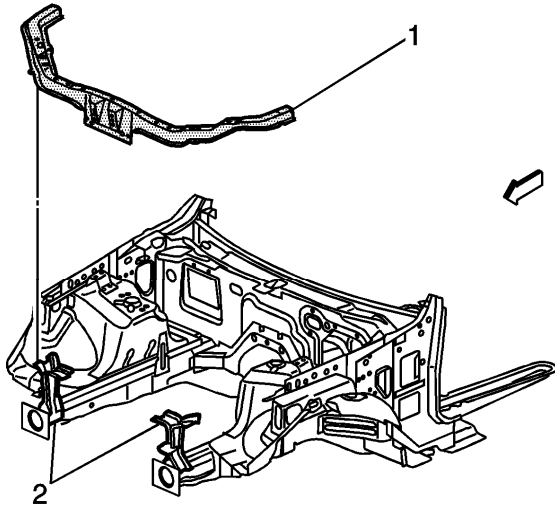

Caution: Refer to [Approved Equipment for Collision Repair Caution](#) in Cautions and Notices.

Important: The front upper tie bar is serviced as 3 components: Right and left side tie bar reinforcements (2) and the upper tie bar (1).

1. Disable the SIR system. Refer to [SIR Disabling and Enabling](#) .
2. Disconnect the negative battery cable. Refer to [Battery Negative Cable Disconnection and Connection](#) .
3. Remove all related panels and components.
4. Restore as much of the damage as possible.
5. Remove the sealers and anti-corrosion materials from the repair area, as necessary. Refer to [Anti-Corrosion Treatment and Repair](#) .
6. Locate, mark, and drill out all factory welds attaching the upper tie bar (1) and reinforcements (2) if necessary.
7. Remove the damaged tie bar (1).

Installation Procedure

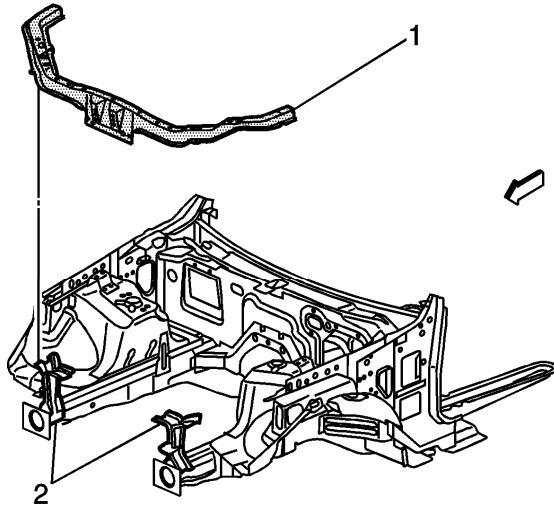

1. Prepare the mating surfaces, as necessary.
2. Apply GM-approved Weld-Thru Coating or equivalent to all mating surfaces. Refer to [Anti-Corrosion Treatment and Repair](#) .
3. Drill 8 mm (5/16 in) plug weld holes on the service part, as necessary, in the locations noted from the original panels.

Important: If the location of the original plug weld holes can not be determined, or if structural weld-thru adhesive is present, space the plug weld holes every 40 mm (1½ in).

4. Temporarily position the upper tie bar (1) and reinforcements (2) on the vehicle.
5. Check location using 3-dimensional measuring equipment.
6. Plug weld accordingly.
7. Clean and prepare welded surfaces.
8. Paint the repaired area. Refer to [Basecoat/Clearcoat Paint Systems](#) .
9. Apply the sealers and anti-corrosion materials to the repair area, as necessary. Refer to [Anti-Corrosion Treatment and Repair](#) .
10. Install all of the related panels and components.
11. Connect the negative battery cable. Refer to [Battery Negative Cable Disconnection and Connection](#) .
12. Enable the SIR system. Refer to [SIR Disabling and Enabling](#) .