

Upper Rail Replacement

Removal Procedure

Caution: Refer to [Approved Equipment for Collision Repair Caution](#) in Cautions and Notices.

1. Disable the SIR system. Refer to [SIR Disabling and Enabling](#) .
2. Disconnect the negative battery cable. Refer to [Battery Negative Cable Disconnection and Connection](#) .

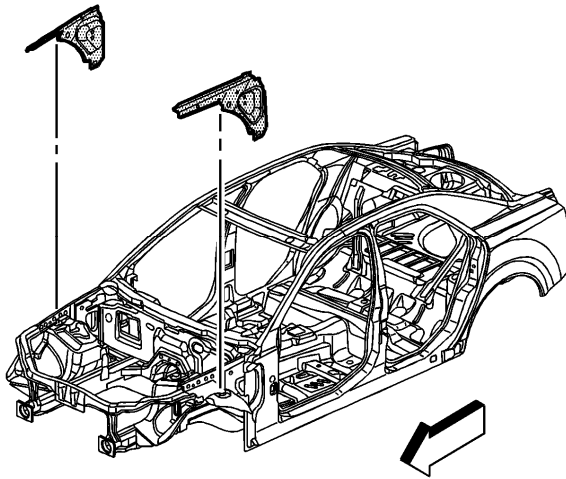

Important: Sectioning of the front upper rails is not recommended.

3. Remove all related panels and components.
4. Restore as much of the damage as possible .
5. Remove the sealers and anti-corrosion materials from the repair area, as necessary. Refer to [Anti-Corrosion Treatment and Repair](#) .
6. Locate, mark, and drill out all factory welds attaching the outer rail.
7. Remove the damaged outer rail.

Installation Procedure

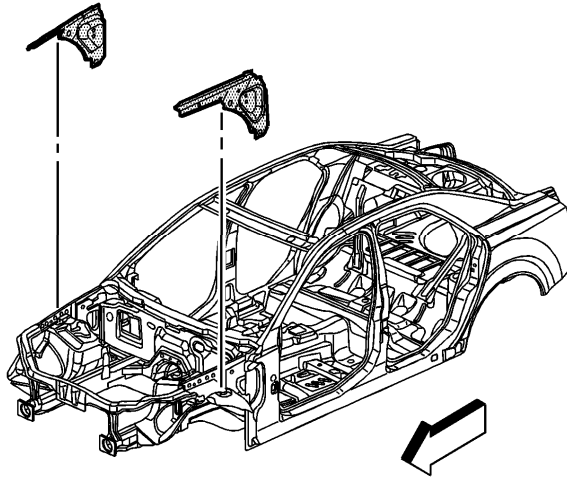

1. Prepare the mating surfaces as necessary.
2. Apply GM-approved Weld-Thru Coating or equivalent to all mating surfaces. Refer to [Anti-Corrosion Treatment and Repair](#) .

Important: If the location of the original plug weld holes can not be determined, or if structural weld-thru adhesive is present, space the plug weld holes every 40 mm (1½ in).

3. Drill 8 mm (5/16 in) plug weld holes as necessary in the locations noted from the original panels.
4. Temporarily position the outer rail on the vehicle.
5. Verify the location using 3-dimensional measuring equipment.
6. Plug weld accordingly.
7. Clean and prepare welded surfaces.
8. Apply the sealers and anti-corrosion materials to the repair area, as necessary. Refer to [Anti-Corrosion Treatment and Repair](#) .
9. Paint the repaired area. Refer to [Basecoat/Clearcoat Paint Systems](#) .
10. Install all of the related panels and components.
11. Connect the negative battery cable. Refer to [Battery Negative Cable Disconnection and Connection](#) .
12. Enable the SIR system. Refer to [SIR Disabling and Enabling](#) .