

Front Wheelhouse Assembly

Important: Both the driver-side and passenger-side front wheelhouses are available as complete sub-assemblies with the strut tower attached to the wheelhouse. The strut mounting holes are pre-punched in the service part, which also includes all necessary component stud mounts. When replacing a wheelhouse, carefully position the service assembly using three-dimensional measuring equipment to properly locate the wheelhouse.

Important: Do not replace the entire wheelhouse when damage is limited to the front portion of the wheelhouse assemblies. In such a situation, the technician can section the wheelhouse. (See Front Wheelhouse Sectioning Procedures.)

Important: Inspect for damage where the wheelhouse is attached to the cowl panel. If the panels have been separated, it will be necessary to repair the cowl panel and replace the wheelhouse (Fig. 4.5). If the panels have not been separated and there is no damage in this location, the wheelhouse can be sectioned.

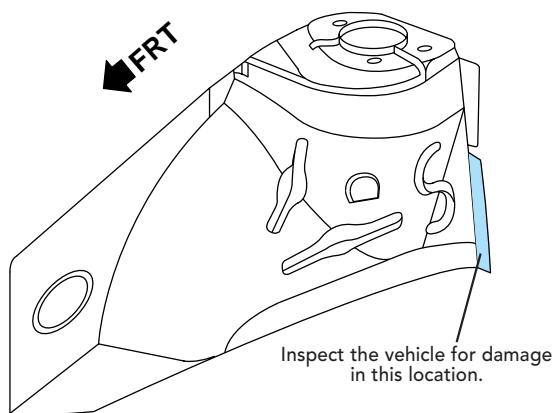

Fig. 4.5 — Wheelhouse Assembly

Front Wheelhouse Sectioning

— REMOVE OR DISCONNECT —

- 1 Remove panels and components as necessary for access.
- 2 Restore as much of the damage as possible to factory specifications.
- 3 Place 25mm (1 inch) wide masking tape following the forward contour of the strut tower. Cut the wheelhouse along the outside edge of the masking tape (Fig. 4.6).
- 4 Locate, mark, and drill out the factory welds attaching the wheelhouse to the radiator support and the upper and lower front rails.
- 5 Remove the damaged section of the wheelhouse.

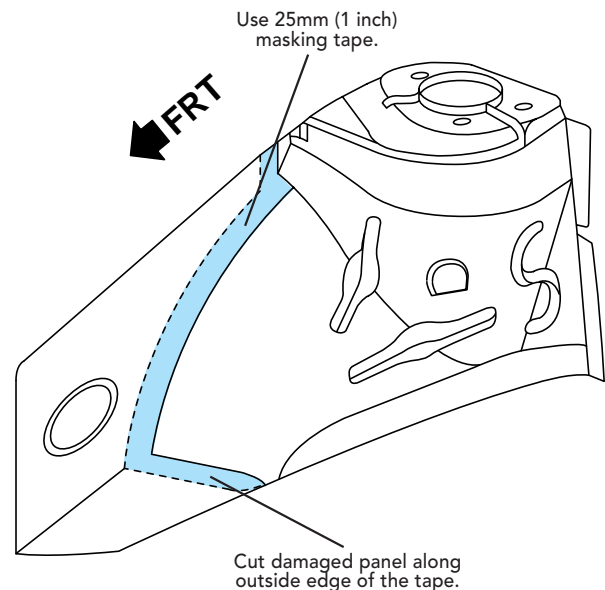

Fig. 4.6 — Sectioning Damaged Wheelhouse

Front Wheelhouse Assembly

— INSTALL OR CONNECT —

- 1 When preparing the service part, cut the forward apron well beyond the 25mm (1 inch) overlap needed for sectioning (Fig. 4.7).
- 2 Temporarily position the new wheelhouse section on the vehicle, and mark a line on the new wheelhouse section by tracing along the cut line of the original wheelhouse (Fig. 4.7). Remove the new wheelhouse section.
- 3 Measure and cut 25mm (1 inch) inboard along the traced line to create an overlap, when installed the original wheelhouse will overlap the modified service part.
- 4 Drill an 8mm (5/16 inch) hole every 35mm along the overlap on the new wheelhouse section (Fig. 4.7).
- 5 Position the new wheelhouse section, check the fit, and plug weld on the outboard side of the panel as necessary.
- 6 Clean and prepare all bare metal surfaces. Apply as necessary:
 - sealers and anti-corrosion materials
 - two-part catalyzed primer
 - top-coat

Important: Do not combine paint systems. Refer to paint manufacturer's recommendations.
- 7 Install all the panels and components previously removed for access.

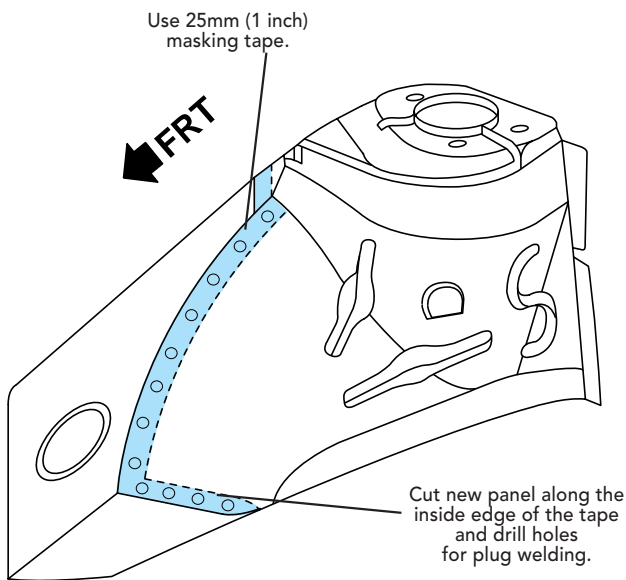

Fig. 4.7 — New Service Panel

Front Wheelhouse Replacement

— REMOVE OR DISCONNECT —

- 1 Remove panels and components as necessary for access.
- 2 Restore as much of the damage as possible to the factory specifications.
- 3 Remove all sealers and anti-corrosion materials as necessary.
- 4 Place a piece of 25mm (1 inch) wide masking tape (Fig. 4.8), on the forward contour of the wheelhouse at the flange where it attaches to the cowl panel.
- 5 Cut the wheelhouse along the forward edge of the masking tape to leave a 25mm (1 inch) tab extending forward from the cowl panel. *(This will provide an overlap for welding the service part to the original wheelhouse, without welding directly to the cowl panel.)*
- 6 Locate, mark, and drill out the factory welds which attach the wheelhouse assembly at the:
 - upper rail inner panel
 - cowl panel
 - radiator support
 - lower front rails
- 7 Remove the damaged wheelhouse assembly.

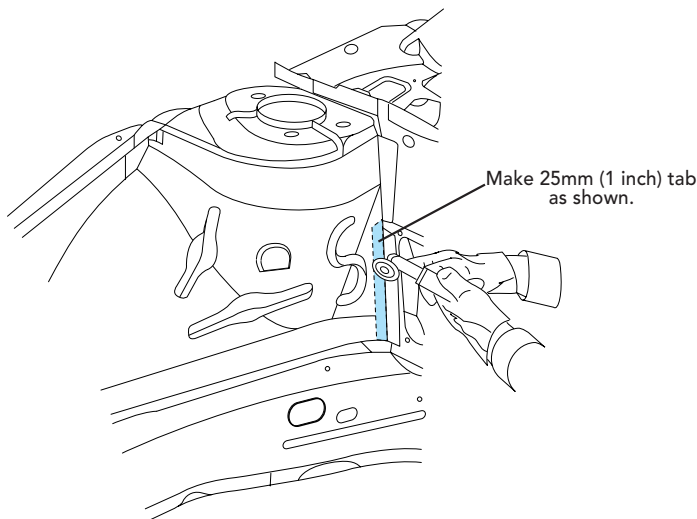

Fig. 4.8 — Cut Wheelhouse 25mm (1 inch) Forward of the Cowl Panel

— INSTALL OR CONNECT —

- 1 Clean and prepare surfaces to be welded.
- 2 Cut the flange off the service part that is normally welded to the cowl panel (Fig. 4.9).
- 3 Drill 8mm (5/16 inch) holes for plug welding in the locations noted from the original assembly. Also drill holes for plug welding every 40mm (1-1/2 inches) along the cut edge to be attached to the tab remaining from the original assembly.

Caution: Watch for flammable materials when welding to the interior panels of the vehicle.

- 4 Position the wheelhouse assembly using three-dimensional measuring equipment.
- 5 Plug weld the wheelhouse as necessary.
- 6 Clean and prepare all bare metal surfaces. Apply as necessary:
 - sealers and anti-corrosion materials
 - sound deadeners
 - two-part catalyzed primer
 - top-coat

Notice: Do not combine paint systems. Refer to paint manufacturer's recommendations.

- 7 Install the panels and components previously removed for access.

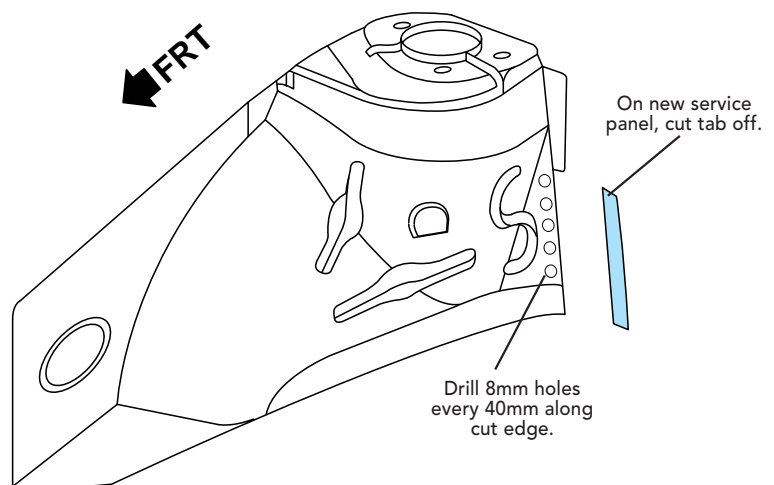

Fig. 4.9 — Cut Tab and Drill Holes