

## Structure Identification

### Inner Panel Identification

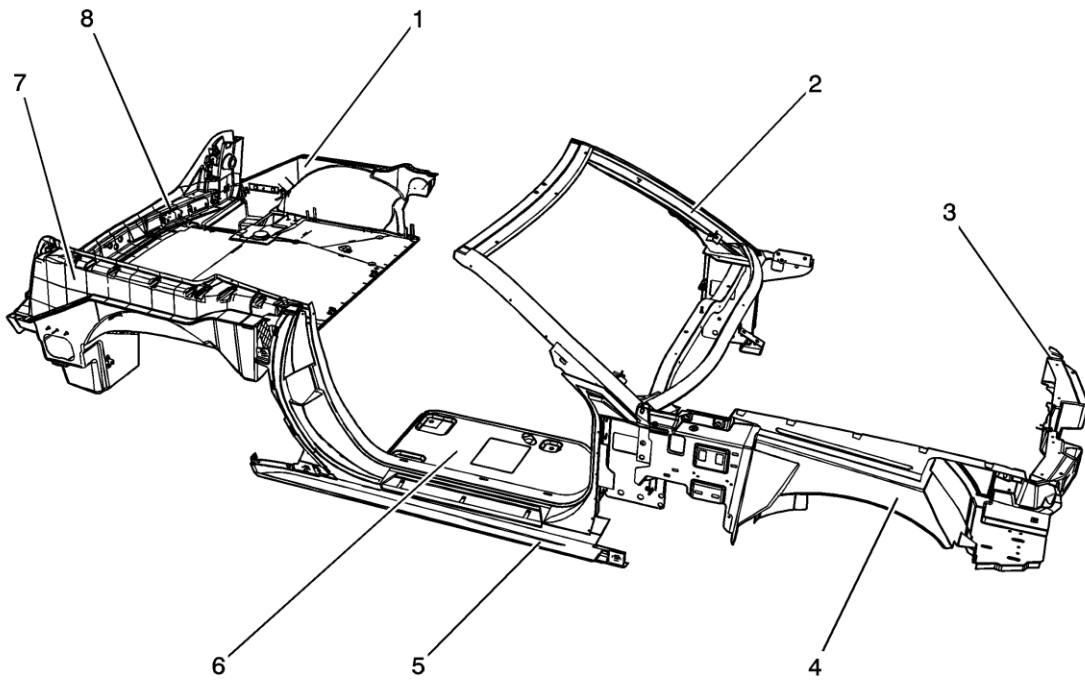

Number	Description	Material	Procedure
1	Rear Compartment Panel	<a href="#">Sheet Molded Compound (SMC)</a> <a href="#">Panel Bonding</a>	<a href="#">Rear Compartment Panel Replacement</a>

2	Windshield Frame	Aluminum	<a href="#">Windshield Frame Replacement</a>
3	Front End Panel	<a href="#">Sheet Molded Compound (SMC) Panel Bonding</a>	<a href="#">Front End Panel Replacement</a>
4	Front Wheelhouse	<a href="#">Sheet Molded Compound (SMC) Panel Bonding</a>	<a href="#">Front Wheelhouse Replacement</a>
5	Side Door Frame Opening	<a href="#">Sheet Molded Compound (SMC) Panel Bonding</a>	<a href="#">Side Door Opening Frame Replacement</a>
6	Floor Panel	<a href="#">Sheet Molded Compound (SMC) Panel Bonding</a>	<a href="#">Floor Panel Replacement</a>
7	Rear Compartment Panel Frame	<a href="#">Sheet Molded Compound (SMC) Panel Bonding</a>	<a href="#">Rear Compartment Panel Frame Replacement</a>
8	Rear End Panel	<a href="#">Sheet Molded Compound (SMC) Panel Bonding</a>	<a href="#">Rear End Panel Replacement</a>

## Frame Identification

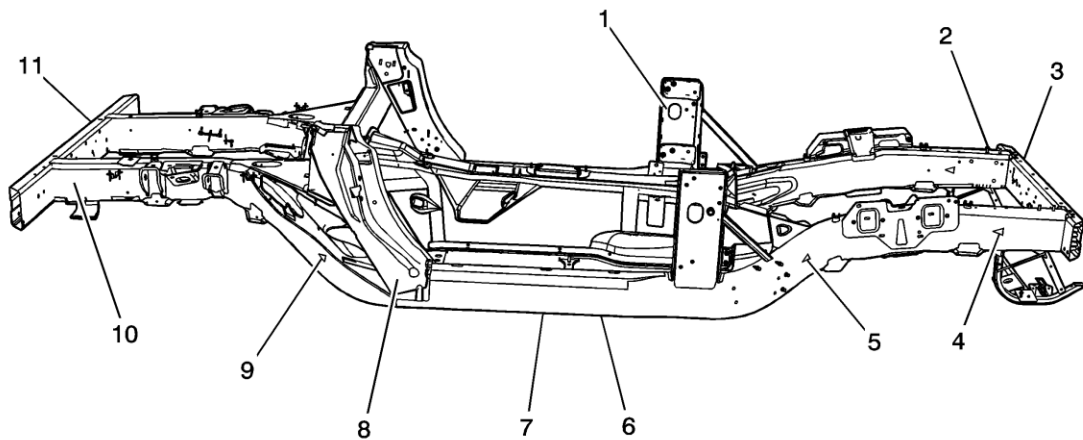

<b>Number</b>	<b>Description</b>	<b>Material</b>	<b>Procedure</b>
1	Front Body Hinge Pillar	<a href="#">Mild Steel</a>	<a href="#">Front Hinge Pillar Body Replacement</a>
2	Hood Plate Stud	<a href="#">Mild Steel</a>	<a href="#">Hood Plate Stud Replacement</a>
3	Front Bumper Impact Bar	<a href="#">Ultra High Strength Steel</a>	<a href="#">Front Bumper Impact Bar Replacement</a>
4	Front Rail End	<a href="#">Mild Steel</a>	<a href="#">Front Rail End Replacement</a>
5	Front Rail Section	<a href="#">Mild Steel</a>	<a href="#">Rail Replacement - Front Section</a>
6	Front Rail	<a href="#">Mild Steel</a>	<a href="#">Front Rail Replacement</a>
7	Rear Rail	<a href="#">Mild Steel</a>	<a href="#">Rear Rail Replacement</a>
8	Front Door Lock	<a href="#">Mild Steel</a>	<a href="#">Body Lock Pillar Outer Panel</a>

	Pillar		<a href="#">Replacement</a>
9	Rear Rail Section	<a href="#">Mild Steel</a>	<a href="#">Rail Replacement - Rear Section</a>
10	Rear Rail End	<a href="#">Mild Steel</a>	<a href="#">Rear Rail End Replacement</a>
11	Rear Bumper Impact Bar	<a href="#">Ultra High Strength Steel</a>	<a href="#">Rear Bumper Impact Bar Replacement</a>