

## Impact Bar Replacement - Rear Bumper

### Tools Required

J 42058 Frame Adapter Clamp

### Removal Procedure

**Caution:** To avoid personal injury when exposed to welding flashes or to galvanized (Zinc Oxide) metal toxic fumes while grinding/cutting on any type of metal or sheet molded compound, you must work in a properly ventilated area, wearing an approved respirator, eye protection, earplugs, welding gloves, and protective clothing.

1. Disable the SIR system. Refer to *SIR Disabling and Enabling Zones* on page 2-66.
2. Disconnect the negative battery cable.
3. Remove all related panels and components.
4. Remove or reposition the wiring to avoid damage.
5. Repair as much of the damage as possible to the factory specifications. Refer to *Dimensions - Body* on page 2-2 and *Measurements - Underbody* on page 2-4.
6. Use J 42058 to secure the vehicle if pulling and straightening are required.
7. Locate the raised area (1) over the top welds of the rear bar.
8. Cut out an access hole (1) over the top welds of the rear bar.
9. Save the cut-out piece to patch the hole.
10. Note the location and remove the sealers and anti-corrosion materials from the repair area. Refer to *Anti-Corrosion Treatment and Repair* on page 1-5 in General Information.
11. Apply heat and pry apart to separate the impact bar from the rear compartment panel.

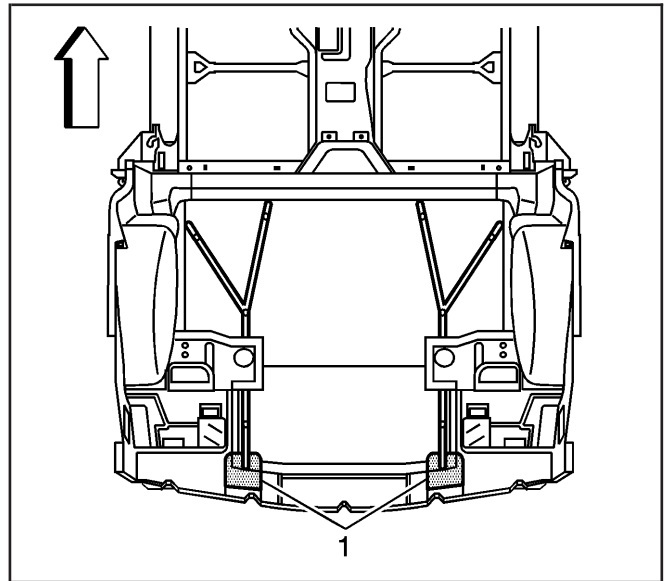

1233792

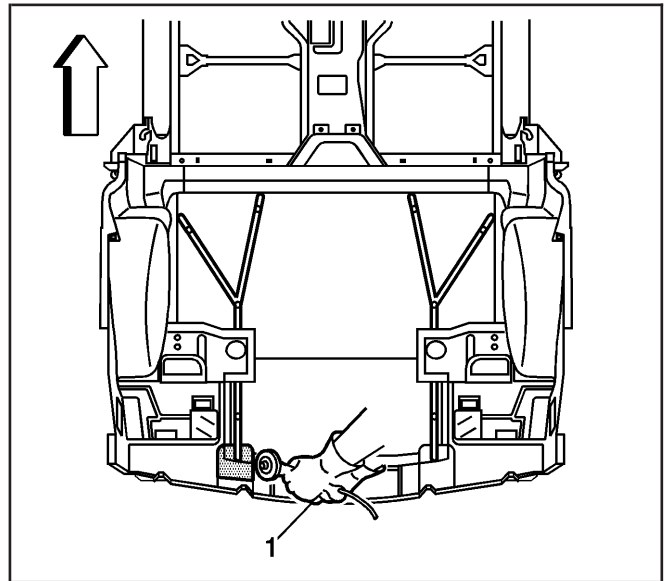

1233790

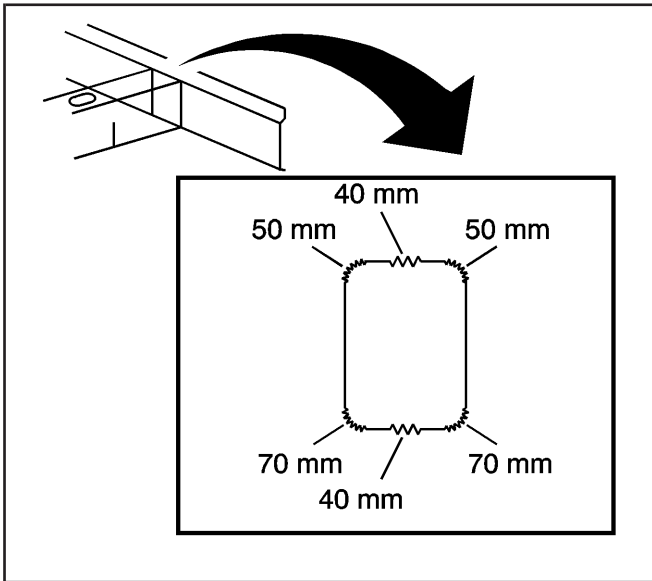

1205122

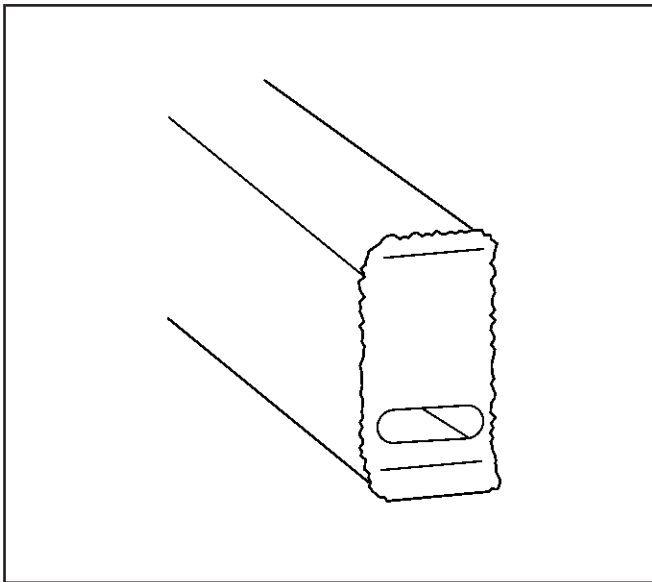

181153

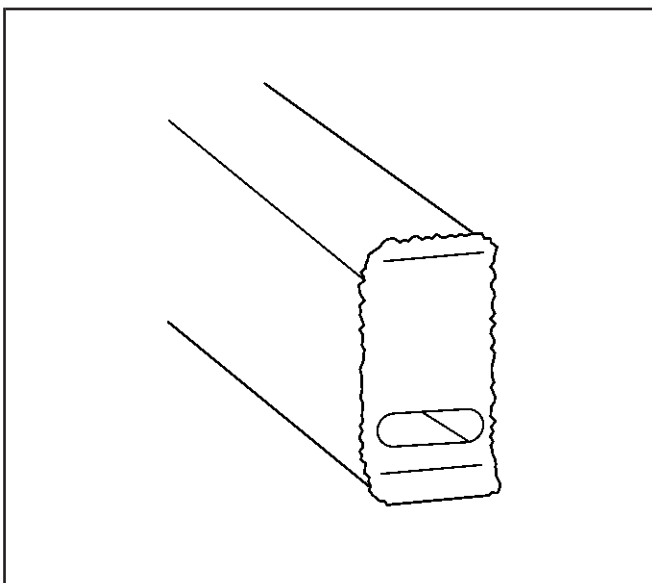

181153

**Important:** Do not cut into the frame rails.

12. Cut the welds around the perimeter of the frame rail ends. Cut the welds favoring the impact bar side of the joint.
13. Remove the damaged impact bar.

14. Extract pieces of the impact bar which are left attached to the rail ends.
15. Straighten and deburr the rail ends. Keep the perimeter and shape of the rail ends as original as possible.

### Installation Procedure

1. Temporarily position the impact bar for proper fit and alignment.
2. Clean and prepare all of the welded surfaces.
3. Apply 3M<sup>®</sup> weld-thru coating P/N 05916 or equivalent as necessary and to the inside of the rail ends.

**Important:** DO NOT top coat the bonding surface of the rear bar. Use primer only on bonding surfaces. Refer to adhesive manufacturer's recommendations.

4. Clean and prepare all bonding mating surfaces according to adhesive manufacturer's recommendations.
5. Apply a consistent bead of structural adhesive to the top impact bar to bond to the rear compartment panel. Refer to *Sheet Molded Compound (SMC) Panel Bonding* on page 2-56.

- Position the bumper impact bar to the vehicle using three-dimensional measuring equipment. Refer to *Dimensions - Body* on page 2-2 and *Measurements - Underbody* on page 2-4.

**Important:** If no trace of the original welds are present, follow the pattern specified for welding the side rails to the impact bar.

- Using a metal inset gas (MIG) welder, stitch weld the rear bar to the frame rail ends.
- Apply the sealers and anti-corrosion materials to the repair area. Refer to *Anti-Corrosion Treatment and Repair* on page 1-5 in General Information.
- Use the original cut-out piece to patch the hole.

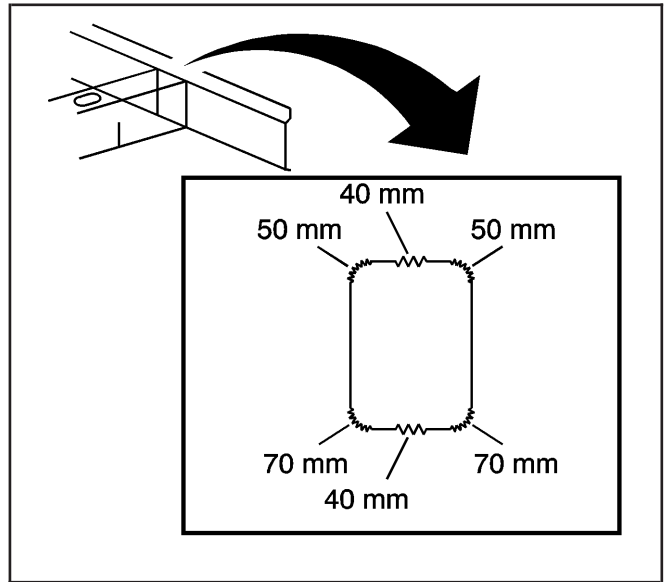

1205122

**Important:** Balsa wood is sandwiched in between the floor. Because balsa wood will rot when wet, complete sealing of the balsa wood is necessary.

- Apply adhesive bonding material as necessary to the repair area of the floor and the patch. Refer to *Sheet Molded Compound (SMC) Panel Bonding* on page 2-56.
- Position the patch and press firmly into place.

**Important:** A leak proof seal is necessary so that exhaust and fuel fumes cannot enter the vehicle.

- Smooth out the adhesive around the repaired area.
- Verify that no voids or gaps occur in the adhesive.
- Paint the repair area. Refer to *Basecoat/Clearcoat Paint Systems* on page 1-7.
- Install all related panels and components.
- Connect the negative battery cable.
- Enable SIR system. Refer to *SIR Disabling and Enabling Zones* on page 2-66.

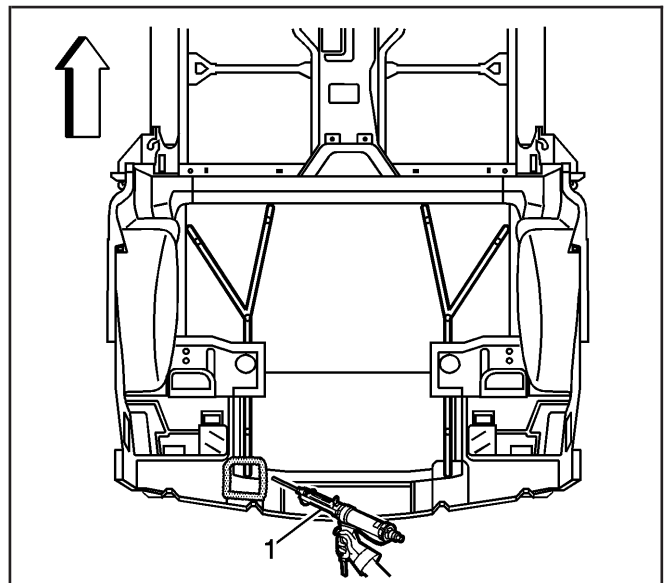

1233797