

860985

Rail Replacement - Front

Tools Required

J 42058 Frame Adapter Clamp

Removal Procedure

Caution: To avoid personal injury when exposed to welding flashes or to galvanized (Zinc Oxide) metal toxic fumes while grinding/cutting on any type of metal or sheet molded compound, you must work in a properly ventilated area, wearing an approved respirator, eye protection, earplugs, welding gloves, and protective clothing.

1. Disable the SIR system. Refer to *SIR Disabling and Enabling Zones* on page 2-66.
2. Disconnect the negative battery cable.
3. Remove all related panels and components.
4. Remove the front impact bar. Refer to *Impact Bar Replacement - Front Bumper* on page 2-5.
5. Note the location and remove the sealers and anti-corrosion materials from the repair area. Refer to *Anti-Corrosion Treatment and Repair* on page 1-5 in General Information.
6. Restore as much of the damage as possible to the factory specifications. Refer to *Dimensions - Body* on page 2-2 and *Measurements - Underbody* on page 2-4.
7. Use J 42058 to secure the vehicle if pulling and straightening is required.
8. Check the front of the dash panel, floor panels, and all other sheet molded compound (SMC) for cracks or areas that may need to be repaired or resealed.
9. Remove the damaged section of frame rail within the shaded area.

Installation Procedure

Caution: Sectioning should be performed only in the recommended areas. Failure to do so may compromise the structural integrity of the vehicle and cause personal injury if the vehicle is in a collision.

1. Determine the sectioning joint location within the recommended area.

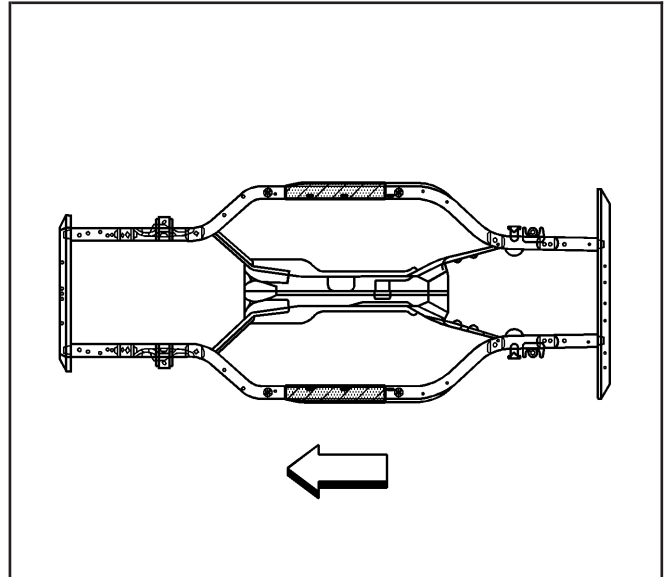

943356

2. Cut the new frame section from the new frame rail assembly.
3. Perform the sleeved butt-joint sectioning. Refer to *Sleeved Butt Joint Repair* on page 2-28.
4. Install the front impact bar. Refer to *Impact Bar Replacement - Front Bumper* on page 2-5.
5. Apply the sealers and anti-corrosion materials to the repair area. Refer to *Anti-Corrosion Treatment and Repair* on page 1-5 in General Information.
6. Paint the repair area. Refer to *Basecoat/Clearcoat Paint Systems* on page 1-7 in General Information.
7. Install all related panels and components.
8. Connect the negative battery cable.
9. Enable SIR system. Refer to *SIR Disabling and Enabling Zones* on page 2-66.

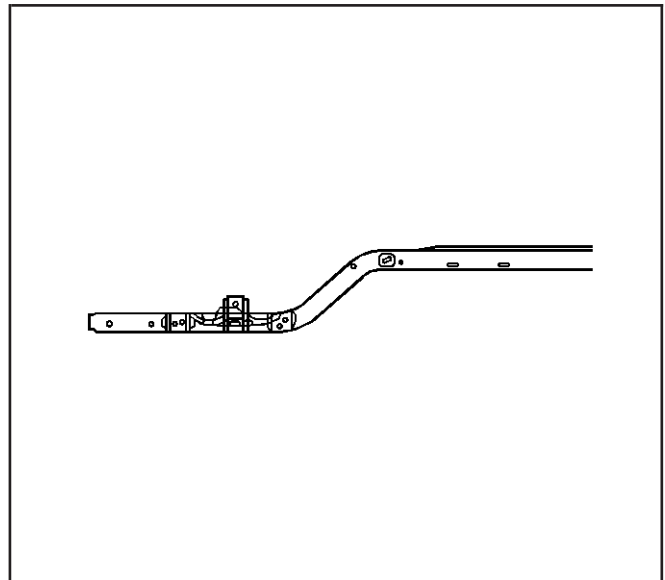

870423