

966577

Floor Panel Replacement

Tools Required

J 42058 Frame Adapter Clamp

Removal Procedure

Caution: To avoid personal injury when exposed to welding flashes or to galvanized (Zinc Oxide) metal toxic fumes while grinding/cutting on any type of metal or sheet molded compound, you must work in a properly ventilated area, wearing an approved respirator, eye protection, earplugs, welding gloves, and protective clothing.

The floor panel is made of sheet molded compound (SMC), and is bonded to the floor structure and frame rail with structural adhesive.

1. Disable the SIR system. Refer to *SIR Disabling and Enabling Zones* on page 2-66.
2. Disconnect the negative battery cable.
3. Remove all related panels and components.
4. Remove or reposition electrical components and wiring harness as necessary to avoid damage.
5. Remove wiring harness clips for transfer to new floor panel.
6. Remove the inner reinforcement (1) bonded to the floor panel and the tunnel area.
7. Remove the outer reinforcement (1) bonded to the floor panel and the frame rail.

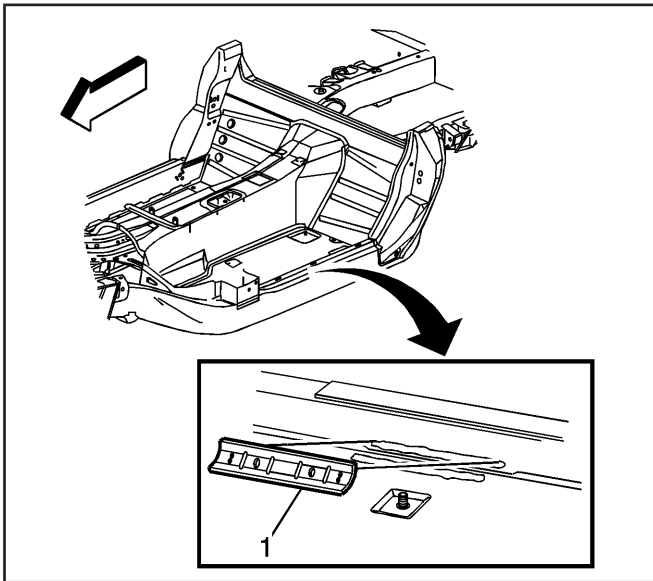

966581

- Apply heat and upward force to the floor panel to detach the adhesive along the bonding surface (1).

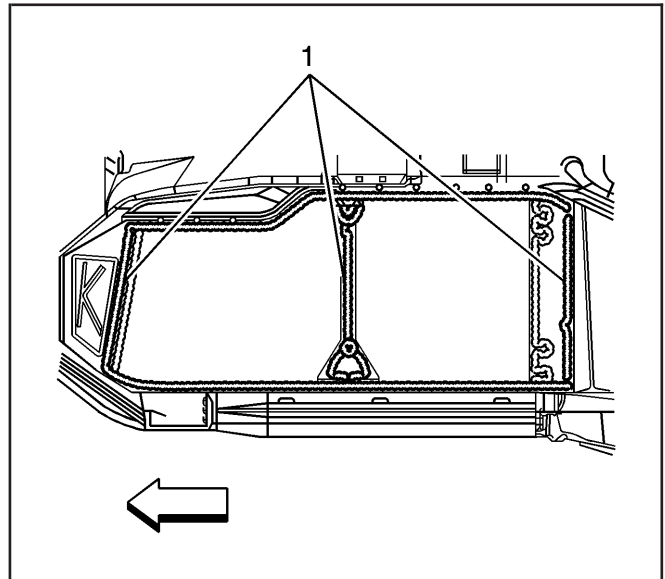

966585

- Remove the floor panel from the vehicle.
- Save any and all brackets, mounting studs, and accessories for transfer to the new floor.
- Note the location and remove all remaining loose adhesive.
- Inspect the structure and frame rails for damage.
- Restore as much of the damage as possible to the factory specifications. Refer to *Dimensions - Body* on page 2-2 and *Measurements - Underbody* on page 2-4.
- Use *J 42058* to secure the vehicle if pulling and straightening is required.

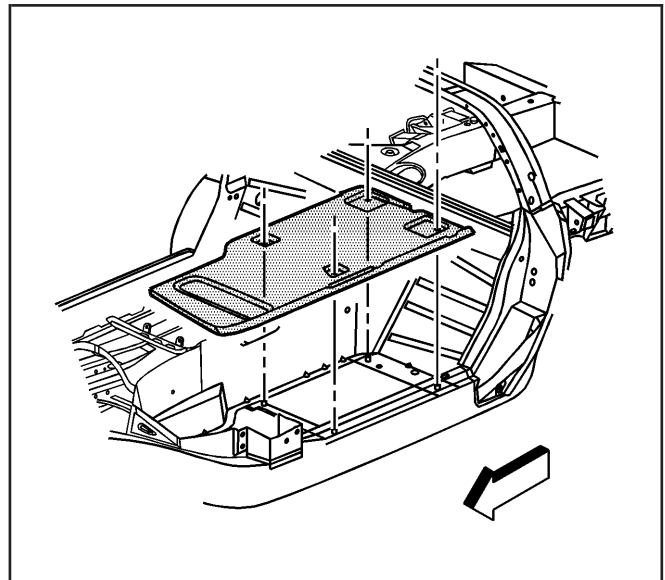

966590

Installation Procedure

- Before applying adhesive dry fit the floor panel for proper fit and alignment.

Important: DO NOT top coat any bonding surface. Use primer only on bonding surfaces. Refer to adhesive manufacturer's recommendations.

- Clean and prepare all bonding mating surfaces according to adhesive manufacturer's recommendations.

Important: Keep adhesive away from seat studs to minimize squeeze out.

- Apply a consistent bead of structural adhesive (1) 10 mm (3/8 in) in diameter to the floor structure and frame rail to mate with the bonding surface of the floor. Refer to *Sheet Molded Compound (SMC) Panel Bonding* on page 2-56.

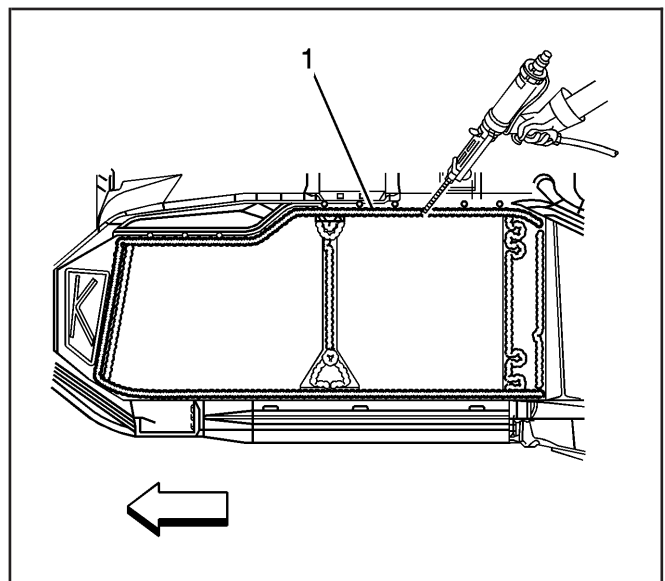

966595

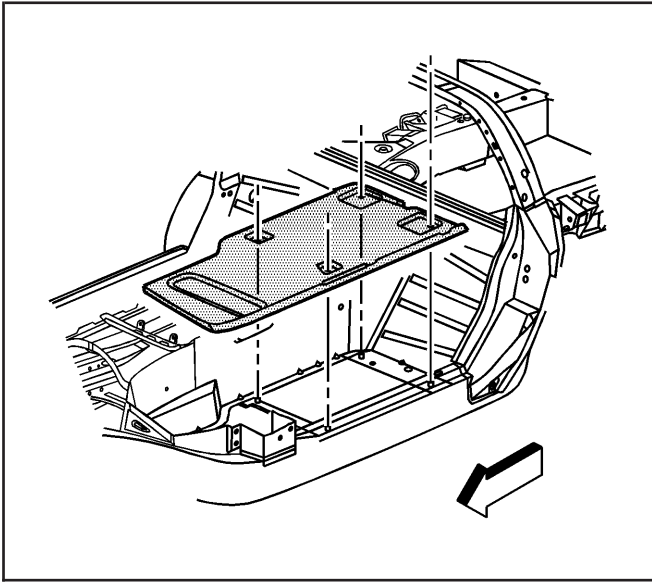

966590

4. Install the floor panel to the vehicle.
5. Apply pressure to the floor panel to set the adhesive.
6. Install the seat mounting nuts to set the adhesive at the cross brace.

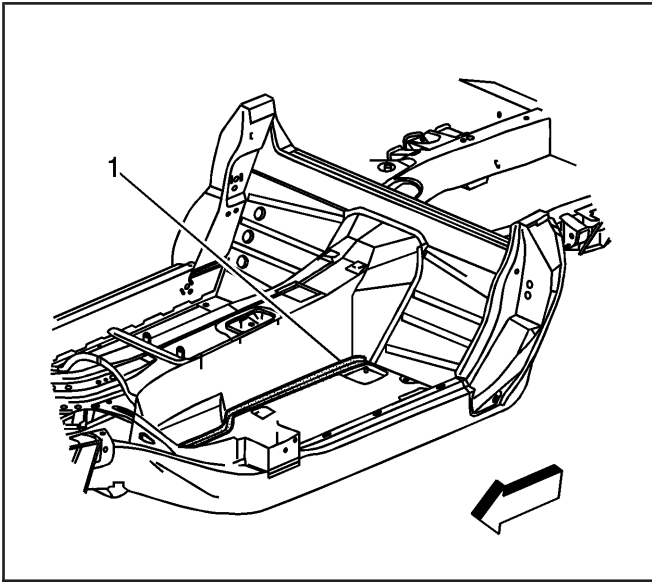

966577

7. Apply structural adhesive (1) to the inner floor panel reinforcement. Refer to *Sheet Molded Compound (SMC) Panel Bonding* on page 2-56.
8. Install the inner floor panel reinforcement to the tunnel.
9. Apply pressure to the reinforcement to set the adhesive.

10. Apply structural adhesive (1) to the outer floor panel reinforcement. Refer to *Sheet Molded Compound (SMC) Panel Bonding* on page 2-56.
11. Install the outer floor panel reinforcement to the frame rail.
12. Apply pressure to the reinforcement to set the adhesive.
13. Apply structural adhesive to wiring harness clips, and install at the etched indicators on the floor panel by pressing firmly into place. Refer to *Sheet Molded Compound (SMC) Panel Bonding* on page 2-56.
14. Smooth adhesive around perimeter of floor panel from underside of vehicle to form a consistent, leak-proof seal.
15. Clamp or mechanically fasten the front end panel into place as necessary.
16. Remove any excess adhesive.
17. Install all related panels and components.
18. Remove the seat mounting nuts.
19. Connect the negative battery cable.
20. Enable the SIR system. Refer to *SIR Disabling and Enabling Zones* on page 2-66.

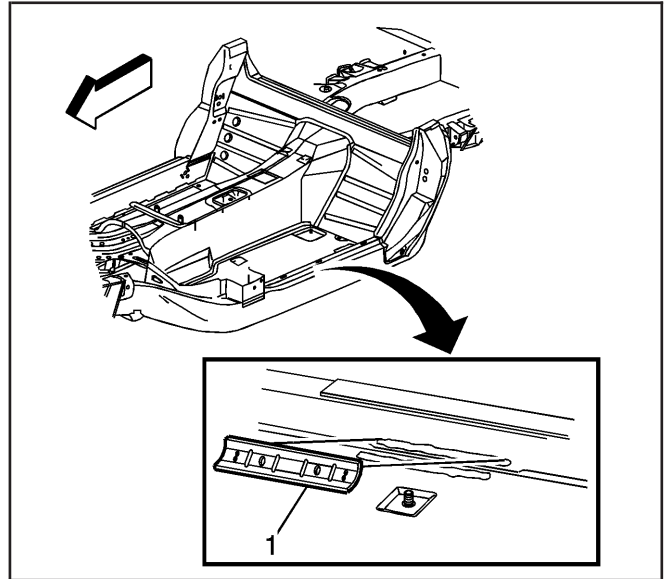

966581