

Rear Lock Pillar Sectioning

Removal Procedure

1. Remove all related panels and components.
2. Restore as much of the damage as possible to factory specifications.
3. Note the location and remove the following as necessary:
 - Sealers
 - Sound deadeners
 - Anti-corrosion materials

IMPORTANT: Take care not to damage the inner panels or reinforcements.

4. Cut the Rear Lock Pillar in the locations where sectioning is to be performed.
5. Locate and drill out all factory welds. Note the number and location of the welds for installation of the service part.
6. Remove the damaged Rear Lock Pillar section.

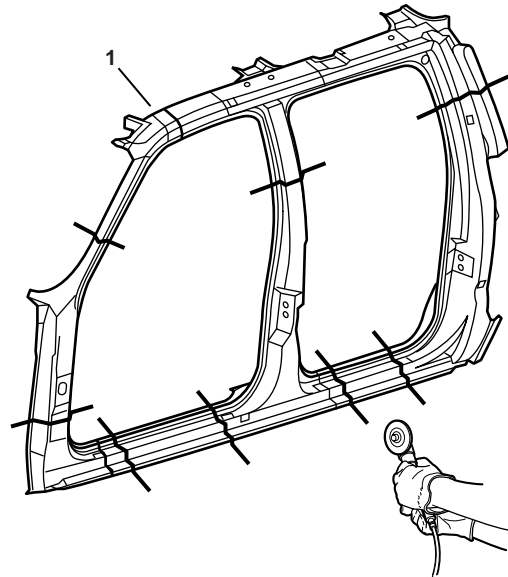

Rear Lock Pillar Sectioning

Installation Procedure

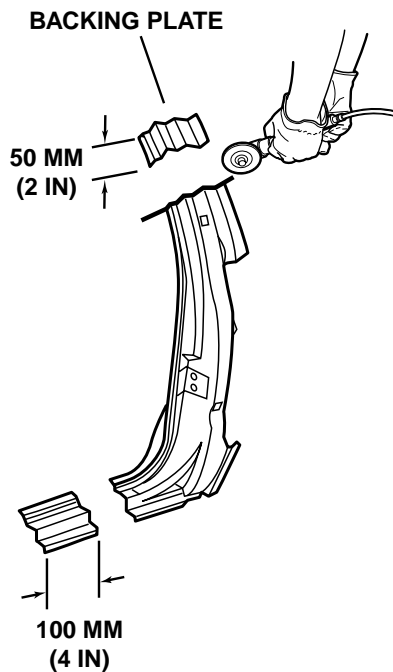

1. Cut the replacement Rear Lock Pillar in corresponding locations to fit the remaining original panel. The sectioning joint should be trimmed to allow a gap of one-and-one-half times the metal thickness at the sectioning joint.
2. Create a 50 mm (2 in.) backing plate from the unused portion of the service part. Trim the backing plate as necessary to fit behind the sectioning joint.
3. Perform additional sectioning procedures as necessary. Refer to Windshield Sectioning; Front Lower Pillar Sectioning; Center Pillar; and Rocker Sectioning.
4. Drill 8 mm (5/16 in.) plug weld holes along the sectioning cut on the remaining original part.
5. Drill 8 mm (5/16 in.) plug weld holes in the service panel as necessary in the locations noted from the original panel and along the sectioning cut.

CAUTION: FOAM SEALERS ARE FLAMMABLE AND SHOULD BE REMOVED FROM ALL WELD LOCATIONS.

6. Prepare the mating surfaces, as necessary.
7. Apply weld-through primer to all bare metal surfaces.

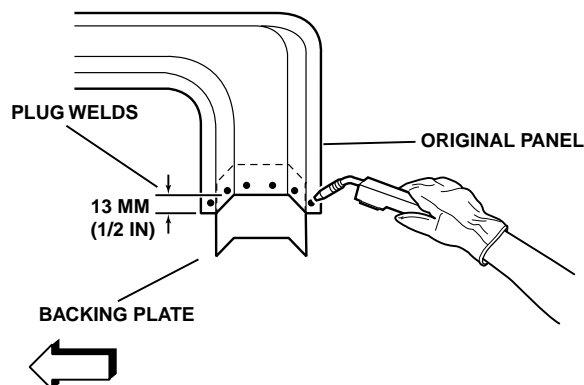

8. Fit the backing plate halfway into the sectioning joint, clamp and plug weld to the vehicle.

Rear Lock Pillar Sectioning Installation Procedure con't

9. Align the Rear Lock Pillar to adjacent panels using three-dimensional measuring equipment.
10. Plug weld accordingly.
11. Make 25 mm (1 in.) stitch welds along the seam with 25 mm (1 in.) gaps between them, then go back and complete the stitch weld. This will create a solid joint with minimal heat distortion.
12. Clean and prepare all welded surfaces.
IMPORTANT: Prior to refinishing, refer to the publication GM4901M-D-01 GM Approved Refinish Materials for recommended products. Do not combine paint systems. Refer to paint manufacturer's recommendations.
13. Apply an approved anti-corrosion primer.
14. Apply sealers and refinish as necessary.
15. Install all related panels and components.

