

# Rail End Front Crush Cap Replacement

## Removal Procedure

1. Remove all of the related panels and the components.

*IMPORTANT: If the crush cap is bent or damaged in any way you must replace the crush cap.*

2. Visually inspect the damage. Use three-dimensional measuring in order to restore all of the damage rearward of the Crush Cap to the factory specifications.

*IMPORTANT: Use care not to damage the rail.*

3. Remove the core support mounting bracket.

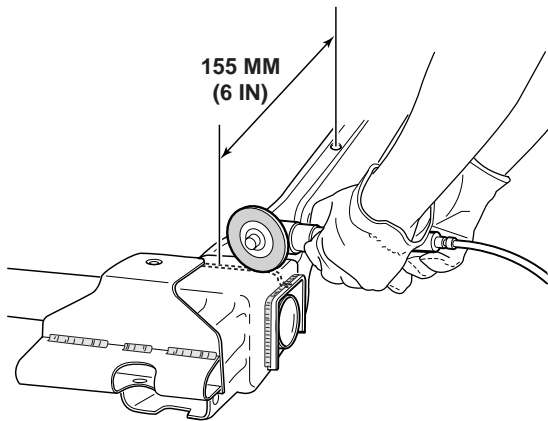
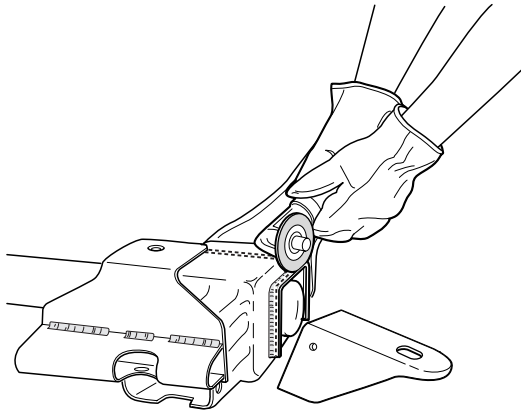

4. Locate the brake line attachment hole on the top of the rail. Measure forward 155 mm (6-1/8 in.). This is the cut line.
5. Scribe a line 360 degrees around the frame rail and in front of the cross tube.

*CAUTION: DO NOT DAMAGE THE CROSS TUBE*

6. Remove the Crush Cap at the cut-line and the forward edge of the cross tube.

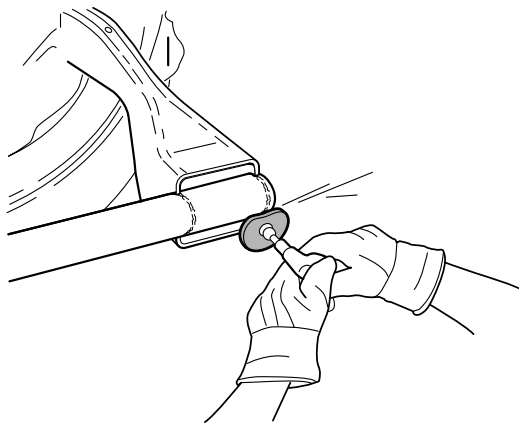

7. Grind the remaining weld off of the cross tube where you removed the damaged Crush Cap.

# Rail End Front Crush Cap Replacement

## Installation Procedure

1. Drill 4 plug weld holes (2 at the top and 2 at the bottom), 13 mm (1/2 in.) from the cut line and 50 mm (2 in.) apart on the existing frame rail.
2. Prepare all of the bare metal surfaces with a suitable weld through primer.

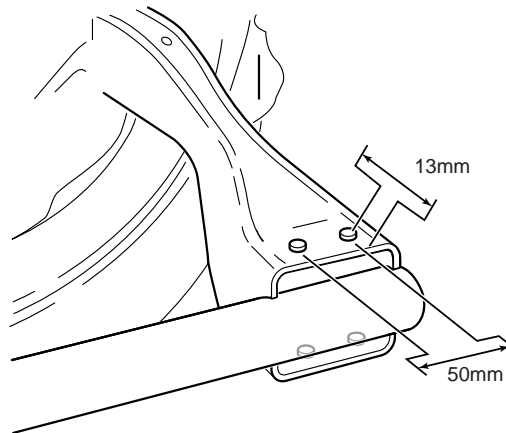

**IMPORTANT:** The replacement bumper bracket is a bolt-on component that must be ordered separately.

**IMPORTANT:** Retain a gap of one and one-half times the metal thickness at the butt joint when attaching the service part to the vehicle.

3. Install and position the replacement Crush Cap using three-dimensional measuring.
4. Tack weld the part into position at the initial plug weld holes.
5. Inspect the service part for proper dimensions.
6. Stitch weld along the entire sectioning joint. Make 25 mm (1 in.) welds along the seam with 25 mm (1 in.) gaps between.
7. Complete the stitch weld.
8. Position the new core support mounting bracket and weld the bracket in place according to the specified dimensions.
9. Clean and prepare the welded surfaces.

**IMPORTANT:** Prior to refinishing, refer to the publication GM4901M-D-01 GM Approved Refinish Materials for recommended products. Do not combine paint systems. Refer to paint manufacturer's recommendations.

10. Apply an approved anti-corrosion primer.
11. Apply the sealers.
12. Refinish the welded surfaces as necessary.
13. Replace the related panels and the components.

