

Front Compartment Front Rail Replacement

Removal Procedure

Important: The support lower arm is joined to the front longitudinal and crossmember dash lower center. It forms the base for the front suspension and is maintaining the rigidity of the front parts. Pay particular attention to the position and dimensions of the weld joints and weld carefully.

Caution: Refer to [Approved Equipment for Collision Repair Caution](#) in Cautions and Notices.

1. Disable the SIR system. Refer to [SIR Disabling and Enabling](#) .
2. Disconnect the negative battery cable.

Important: This assembly is replaced at factory seams.

3. Remove all related panels and components.
4. Repair as much of the damage as possible. Refer to [Dimensions - Body](#) .
5. Remove the sealers and anti-corrosion materials from the repair area, as necessary. Refer to [Anti-Corrosion Treatment and Repair](#) .

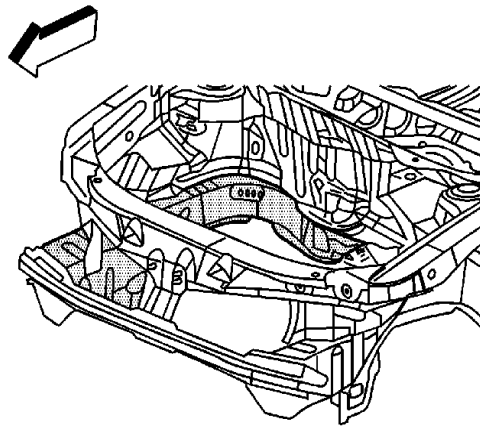

Important: Note the number and location of the factory welds for installation of the full rail service part.

6. Locate and drill out all the necessary factory welds.

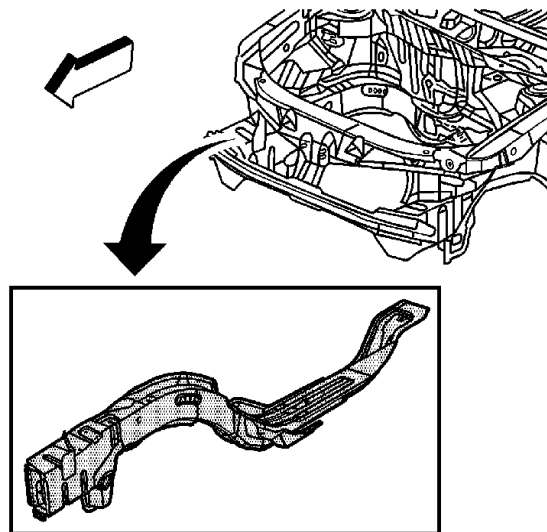

7. Remove the full rail.

Installation Procedure

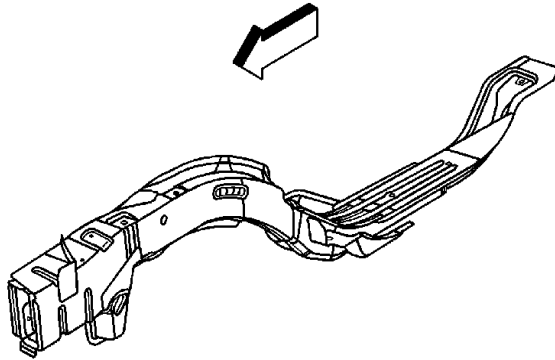

Important: If the location of the original plug weld holes can not be determined, space the plug weld holes every 40 mm (1½ in) apart.

1. Drill 8 mm (5/16 in) plug weld holes in the service part as necessary in the locations noted from the original panel.
2. Prepare all mating surfaces as necessary.
3. Apply GM-approved Weld-Thru Coating or equivalent to all mating surfaces. Refer to [Anti-Corrosion Treatment and Repair](#) .
4. Position the full rail service part to the vehicle using 3-dimensional measuring equipment. Clamp the rail in place.

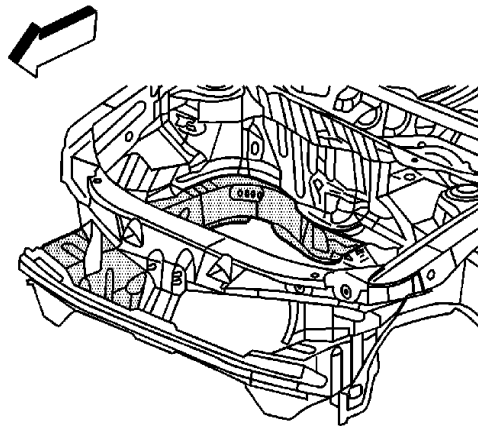

5. Plug weld accordingly.
6. Clean and prepare all of the welded surfaces.
7. Apply the sealers and anti-corrosion materials to the repair area, as necessary.
Refer to [Anti-Corrosion Treatment and Repair](#) .
8. Paint the repaired area. Refer to [Basecoat/Clearcoat Paint Systems](#) .
9. Install all of the related panels and components.
10. Connect the negative battery cable.
11. Enable the SIR system. Refer to [SIR Disabling and Enabling](#) .