

## Body Hinge Pillar Extension Panel Replacement

### Removal Procedure

**Warning:** Refer to [Collision Sectioning Warning](#) in the Preface section.

**Warning:** Refer to [Approved Equipment for Collision Repair Warning](#) in the Preface section.

**Warning:** Refer to [Glass and Sheet Metal Handling Warning](#) in the Preface section.

1. Disable the SIR system. Refer to [SIR Disabling and Enabling](#).
2. Disconnect the negative battery cable. Refer to [Battery Negative Cable Disconnection and Connection](#).
3. Remove all related panels and components.
4. Restore as much of the damage as possible to factory specifications using 3-dimensional measuring equipment.
5. Note the location and remove the sealers and anti-corrosion materials from the repair area, as necessary. Refer to [Anti-Corrosion Treatment and Repair](#).
6. Perform the necessary procedures to gain access to the repair. Refer to [Front Compartment Upper Side Rail Replacement](#).

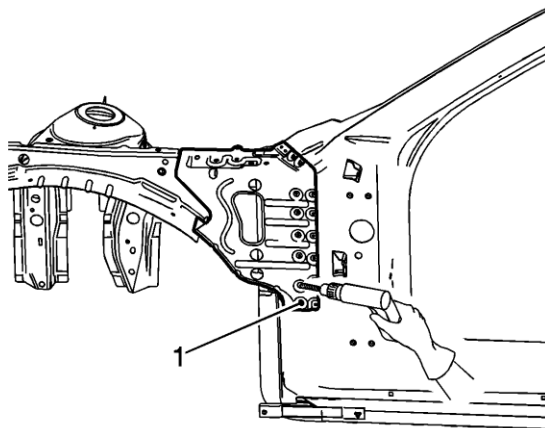

**Note:** Do not damage any inner panels or reinforcements. Record the number and location of the original welds for installation of the service part.

7. Locate and drill out all factory welds (1).
8. Remove the Pillar Extension.

## **Installation Procedure**

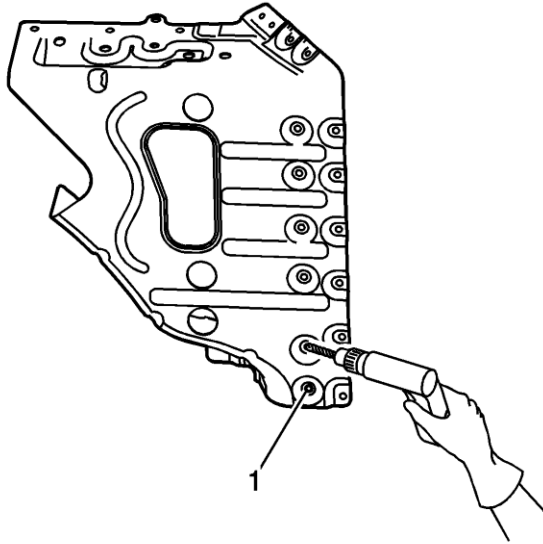

**Note:** If the location of the original plug welds cannot be determined or Structural weld thru adhesive was present, space plug weld holes every 40 mm (1 1/2 in) apart.

1. Drill 8 mm (5/16 in) plug weld holes in the service part as necessary in the locations noted from the original panel (1).
2. Prepare all attachment surfaces as necessary.
3. Apply GM approved Weld-Thru Coating or equivalent to all mating surfaces. Refer to [Anti-Corrosion Treatment and Repair](#).

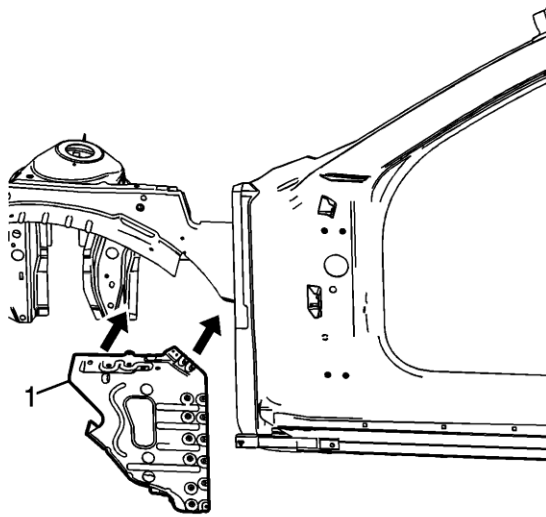

4. Position the Pillar Extension (1).
5. Clamp service parts in position.
6. Inspect the vehicle for proper dimensions using 3-dimensional equipment.

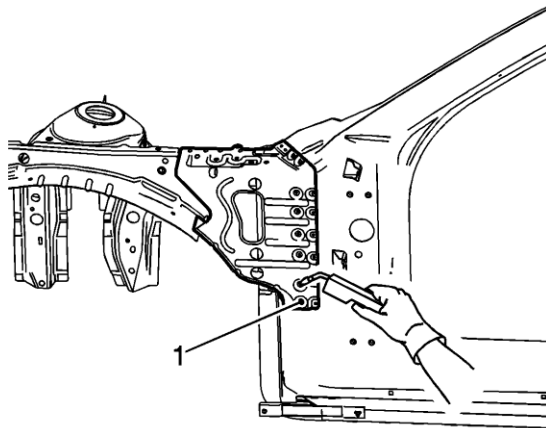

7. Plug weld accordingly (1).
8. Clean and prepare all welded surfaces.
9. Apply the sealers and anti-corrosion materials to the repair area, as necessary. Refer to [Anti-Corrosion Treatment and Repair](#).
10. Paint the repair area. Refer to [Basecoat/Clearcoat Paint Systems](#).
11. Install all related panels and components.
12. Connect the negative battery cable. Refer to [Battery Negative Cable Disconnection and Connection](#).
13. Enable the SIR system. Refer to [SIR Disabling and Enabling](#).

