

## Front Side Door Outer Panel Replacement

### Removal Procedure

**Warning:** Refer to [Approved Equipment for Collision Repair Warning](#) in the Preface section.

**Note:** Before beginning the repair, refer to [Metal Panel Bonding](#) for proper adhesive applicator preparations and general information.

1. Disconnect the negative battery cable. Refer to [Battery Negative Cable Disconnection and Connection](#).
2. Disable the SIR system. Refer to [SIR Disabling and Enabling](#).
3. Remove the door from the vehicle. Refer to [Front Side Door Replacement](#).
4. Remove all related panels and components.

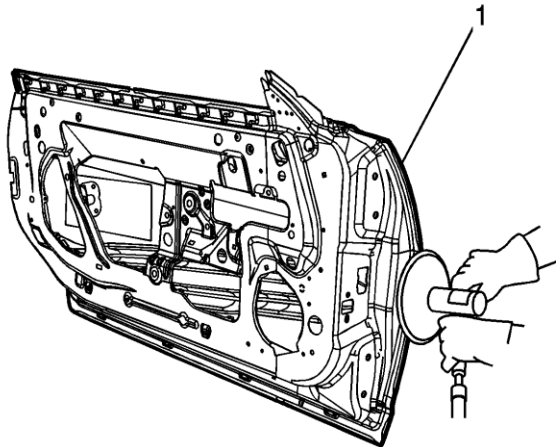

**Note:** The inner belt reinforcement is welded to the door assembly and is not serviced separately. Do not remove it during this procedure. If it is damaged then the door must be replaced.

5. Grind the edges of the door outer panel to separate the outer door panel from the door shell (1).

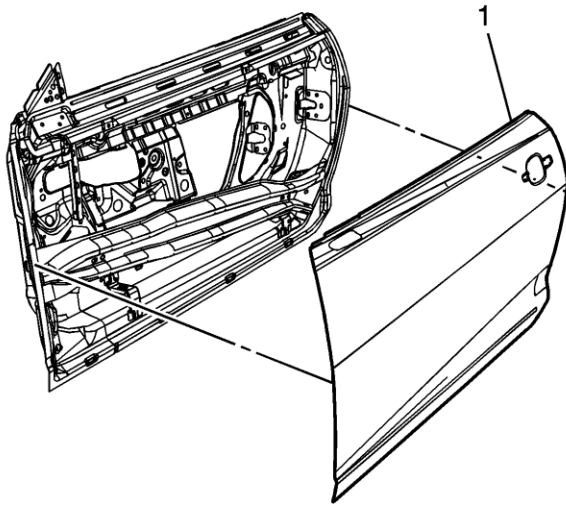

**Warning:** Inspection of the door guard beam for damage must be performed before replacement of the door outer panel. If damage to the door guard beam is found the door must be replaced. Failure to do so may compromise the structural integrity of the vehicle and may cause personal injury if the vehicle is involved in a collision.

6. Remove the outer door panel (1).
7. Remove the sealers and anti-corrosion materials from the repair area, as necessary. Refer to [anti-Corrosion Treatment and Repair](#).

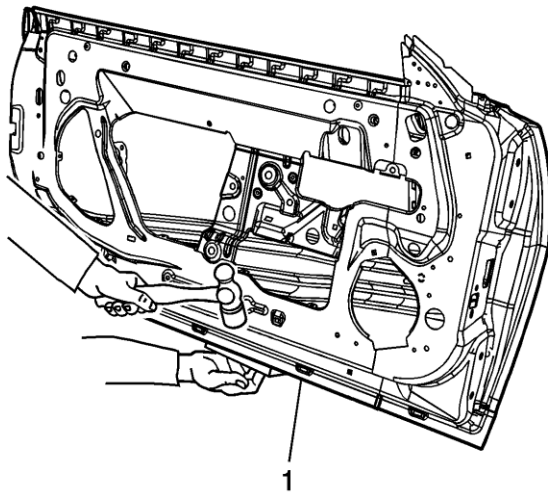

8. Straighten the edges of the door shell (1).

## Installation Procedure

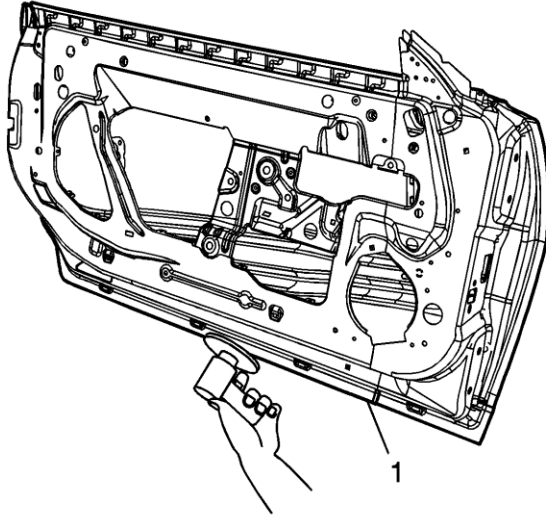

1. Using a grinding disk grind the surface of the door shell mating flanges to bare steel (1).

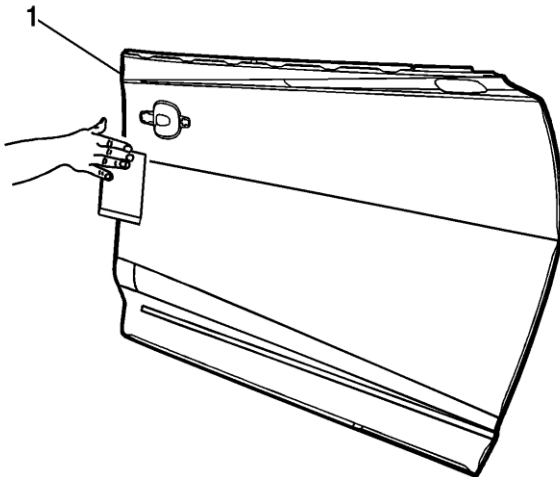

2. Scuff the opposing mating surfaces of the door outer panel to remove the gloss of the E-Coat (1).

3. Clean the mating surfaces.

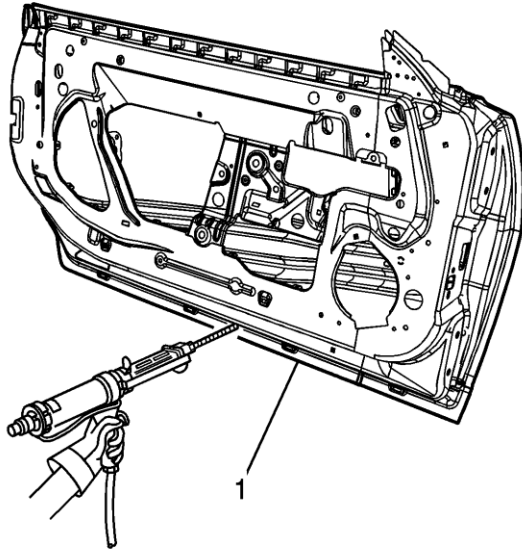

**Note:** Do not allow the adhesive to totally cure off the vehicle, as proper alignment of the door outer panel to the door shell will be difficult.

4. Apply a 3-6 mm (1/8-1/4 in) bead of metal panel bonding adhesive to both of the mating surfaces (1).
5. Using a small acid brush, spread a coat of adhesive to cover all the bare metal surfaces to ensure corrosion protection.

**Note:** Do NOT pull the panels apart after joined together. Slide the panels against each other to realign the panels.

6. Apply a 9-13 mm (3/8-1/2 in) bead of metal panel bonding adhesive to the mating surface of the service panel.

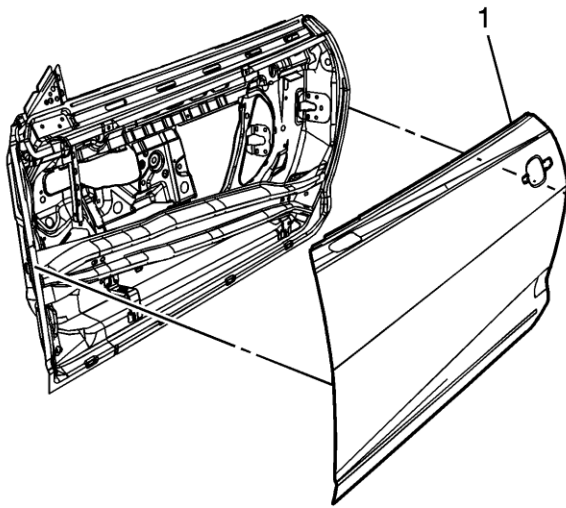

7. Install the door outer panel to the door shell (1).
8. Clamp the door outer panel into position as required.

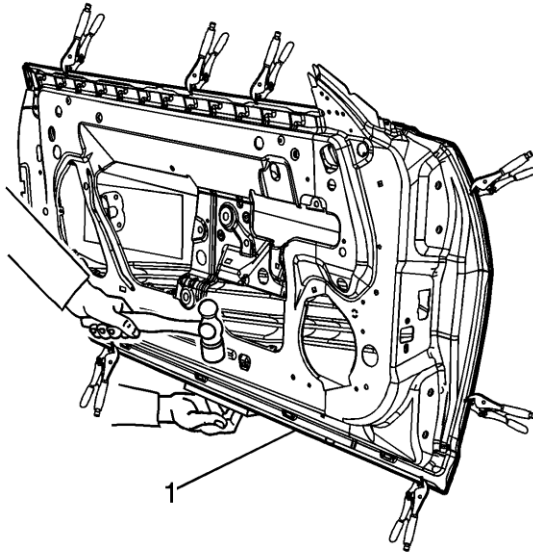

9. Using a hammer, re-hem the hem flanges around the door shell (1).

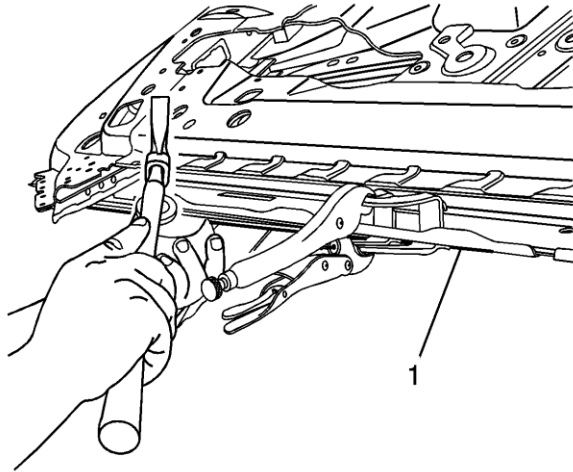

10. Continue to hammer in stages along the hem flanges (1), paying attention to the upper belt flange area due to the close proximity.
11. Using lacquer thinner remove the excess adhesive from the door panel area.
12. Install the door to the vehicle. Inspect the door outer panel for proper alignment. Adjust the alignment as required. Refer to [Front Side Door Replacement](#).
13. Clean and prepare all welded surfaces.

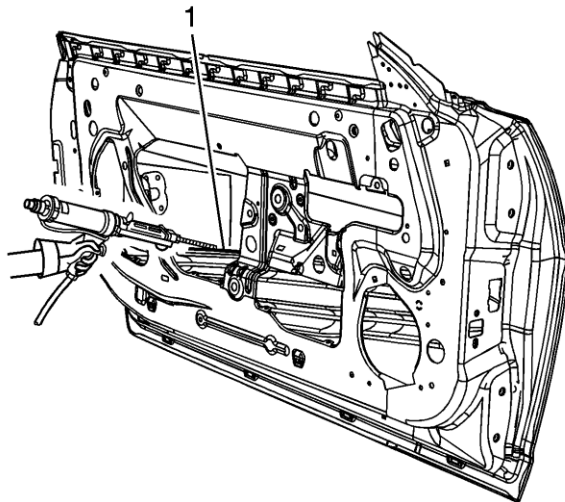

14. Apply Fusor super flexible anti-flutter foam - fast set, Fusor P/N 121/124 or equivalent in 4-5 evenly spaced locations between the door outer panel and the inner safety beam and the upper belt reinforcement (1).
15. Apply sealers and anti-corrosion materials to the repair area as necessary. Refer to [Anti-Corrosion Treatment and Repair](#).
16. Paint the repaired area. Refer to [Basecoat/Clearcoat Paint Systems](#).
17. Install all related panels and components.

18. Enable the SIR system. Refer to [SIR Disabling and Enabling](#).
19. Connect the negative battery cable. Refer to [Battery Negative Cable Disconnection and Connection](#).

© 2009 General Motors Corporation. All rights reserved.