

# Rail Replacement Rear Side Underbody

## Removal Procedure

### **Caution**

Refer to [Approved Equipment for Collision Repair Caution](#) in Cautions and Notices.

1. Disable the SIR system. Refer to [SIR Disabling and Enabling Zones](#) in SIR.
2. Disconnect the negative battery cable. Refer to [Battery Negative Cable Disconnect/Connect Procedure](#) in Engine Electrical.
3. Remove all related panels and components.
4. Repair as much of the damaged area as possible. Refer to [Dimensions - Body](#) .
5. Remove the sealers and anti-corrosion materials from the repair area, as necessary. Refer to [Anti-Corrosion Treatment and Repair](#) in Paint and Coatings.

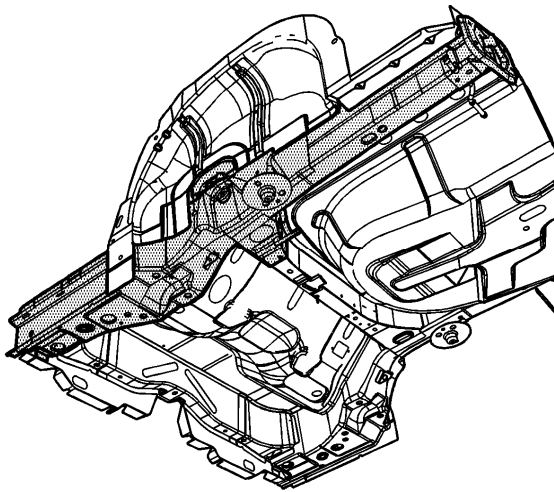

### **Important**

Note the number and location of the factory welds for installation of the wheelhouse - rear inner.

6. Locate and drill out all the necessary factory welds.

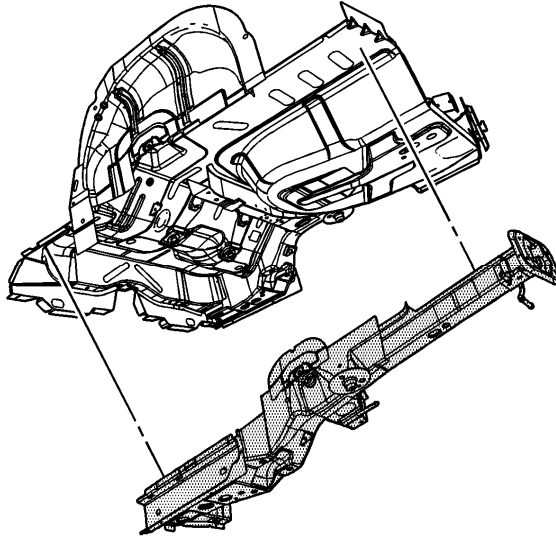

7. Remove the rear rail.

### Installation Procedure

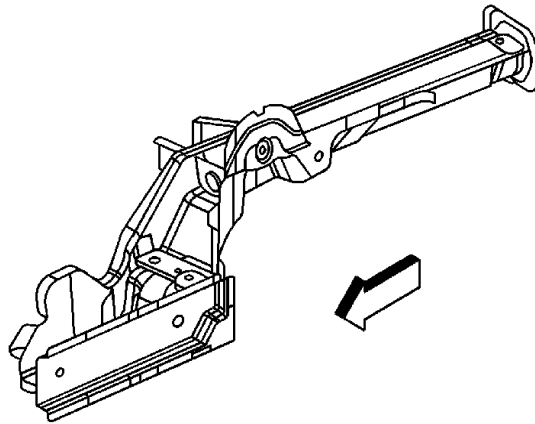

### **Important**

If the location of the original plug weld holes can not be determined, space the plug weld holes every 40 mm (1½ in) apart.

1. Drill 8-mm (5/16-in) plug weld holes in the service part as necessary in the locations noted from the original panel.
2. Prepare all mating surfaces for welding as necessary.
3. Apply GM-approved Weld-Thru Coating or equivalent to all mating surfaces. Refer to [Anti-Corrosion Treatment and Repair](#).

### **Important**

The service part includes an inner rocker rear extension. The rear rail can be installed with or without the extension.

4. If an extension panel is not required, drill out the spot welds.

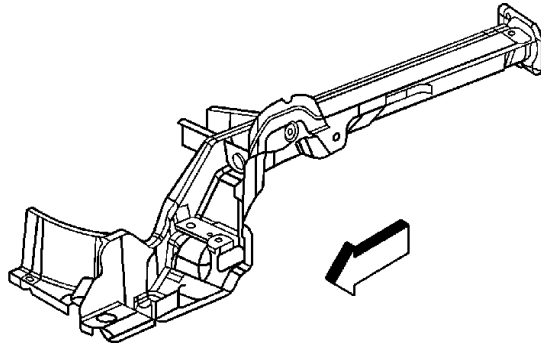

5. Remove the extension panel if necessary.

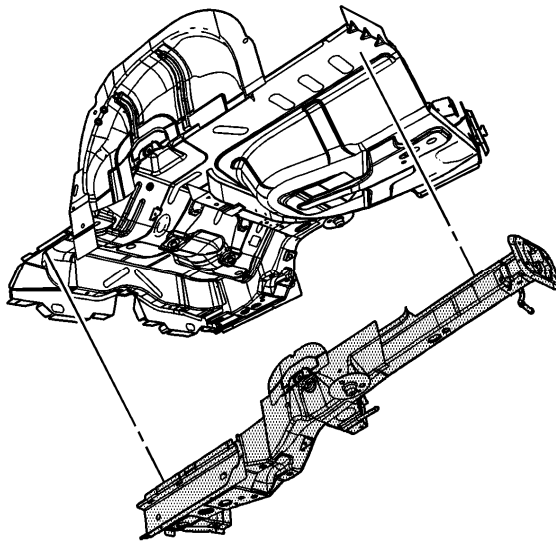

6. Position the rear rail to the vehicle using 3-dimensional measuring equipment. Clamp the rail in place.

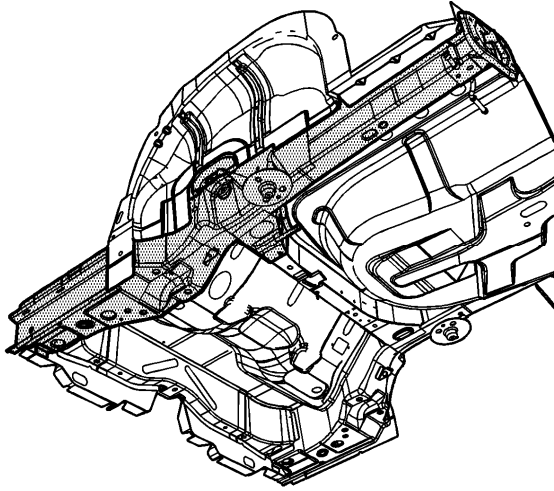

7. Plug weld accordingly.
8. Clean and prepare all of the welded surfaces.
9. Install all of the related panels and components.
10. Apply the sealers and anti-corrosion materials to the repair area, as necessary. Refer to [Anti-Corrosion Treatment and Repair](#) in Paint and Coatings.
11. Paint the repaired area. Refer to [Basecoat/Clearcoat Paint Systems](#) in Paint and Coatings.
12. Connect the negative battery cable. Refer to [Battery Negative Cable Disconnect/Connect Procedure](#) in Engine Electrical.
13. Enable the SIR system. Refer to [SIR Disabling and Enabling Zones](#) in SIR.