

# Rear Compartment Floor Panel Sectioning

## Removal Procedure

### **Caution**

Refer to [Approved Equipment for Collision Repair Caution](#) in Cautions and Notices.

**Caution: Sectioning should be performed only in the recommended areas. Failure to do so may compromise the structural integrity of the vehicle and cause personal injury if the vehicle is in a collision.**

1. Disable the SIR system. Refer to [SIR Disabling and Enabling Zones](#) in SIR.
2. Disconnect the negative battery cable. Refer to [Battery Negative Cable Disconnect/Connect Procedure](#) in Engine Electrical.

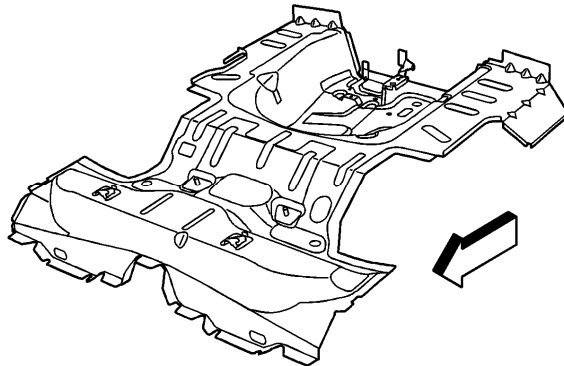

### **Important**

The rear floor pan service part comes as a complete panel. You must make a cut to create the needed part for sectioning.

3. Remove all related panels and components.
4. Remove the sealers and anti-corrosion materials from the repair area, as necessary. Refer to [Anti-Corrosion Treatment and Repair](#) in Paint and Coatings.
5. Repair as much of the damaged area as possible. Refer to [Dimensions - Body](#) .

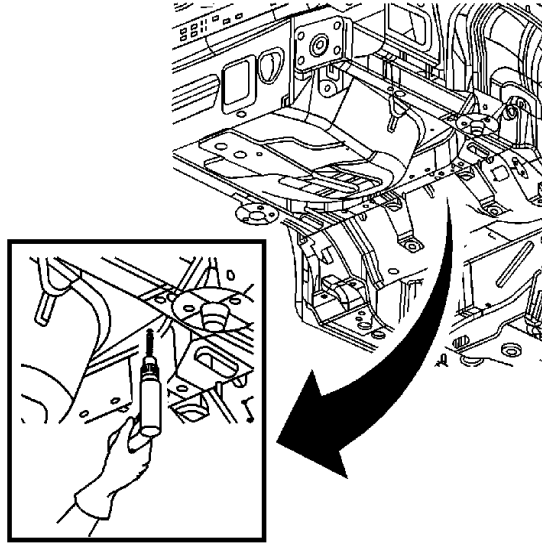

### **Important**

Do not damage any adjacent panels or components when cutting or drilling out spot welds.

6. Locate the rear edge of cross bar #5 from under the vehicle.
7. Drill several 1/8 in holes in the floor pan only along the rear edge of the rear weld flange of cross bar #5. This will aid in identifying the location from the top side of the floor pan.

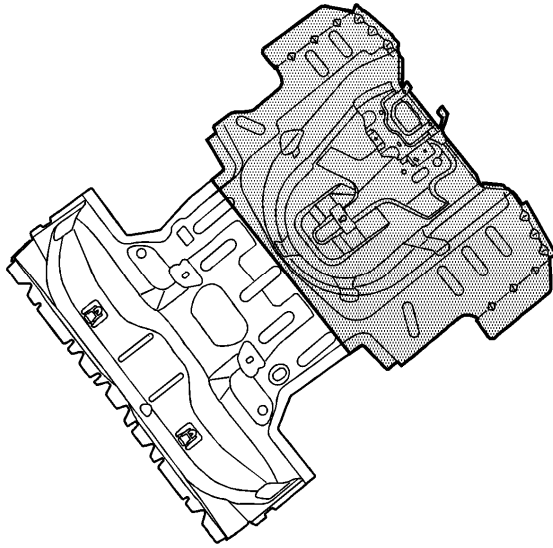

8. Apply a piece of masking tape to the top surface of the rear compartment panel along the holes drilled in the floor pan.

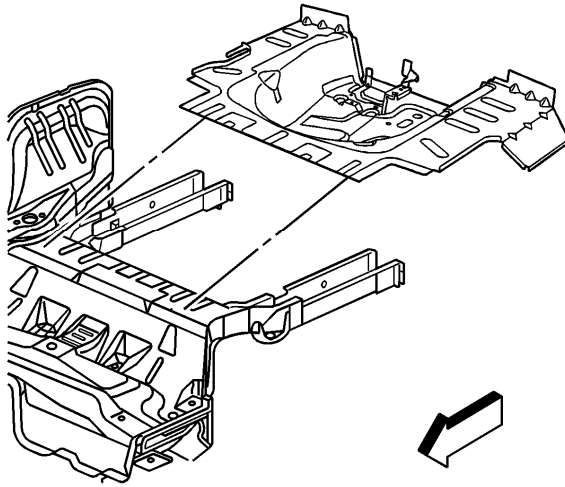

**Important**

Do not damage any inner panels or reinforcements.

9. Cut slightly rearward of the tape along the holes drilled in the floor pan. Later, the floor panel will be ground flush to the rear edge of the weld flange.

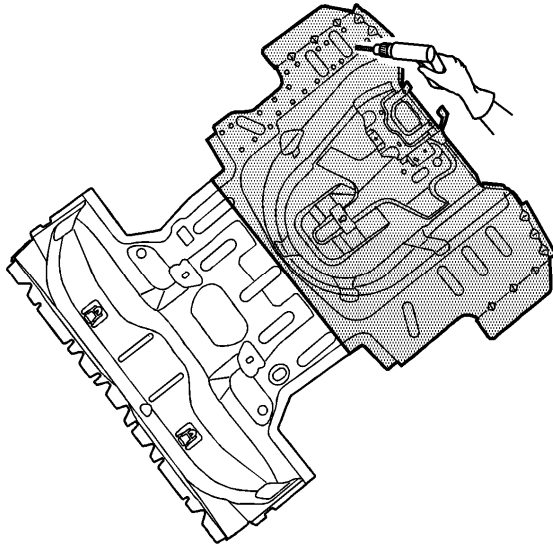

10. Drill out all the spot welds along rails and the wheelhouses rearward of the cutline and remove the rear compartment floor panel. Note the number and location of welds for installation of the service assembly.
11. Cut and grind flush the original panel of the rear compartment panel at the rear edge of the #5 crossbar.

#### Installation Procedure

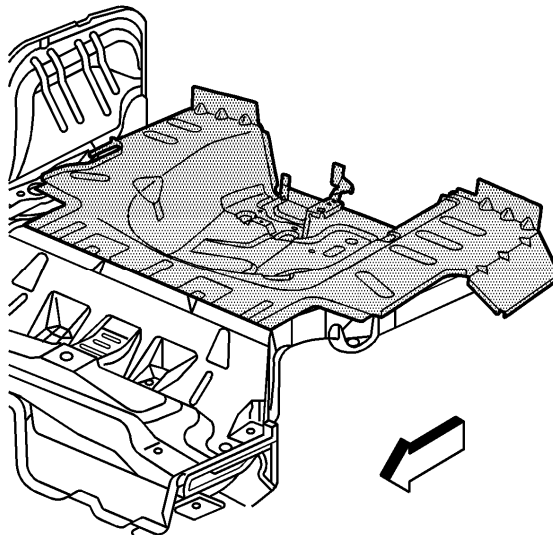

1. On the rear compartment floor panel service part, locate the transition area from the floor pan to the drop-down area which supports the rear seat bottom half.

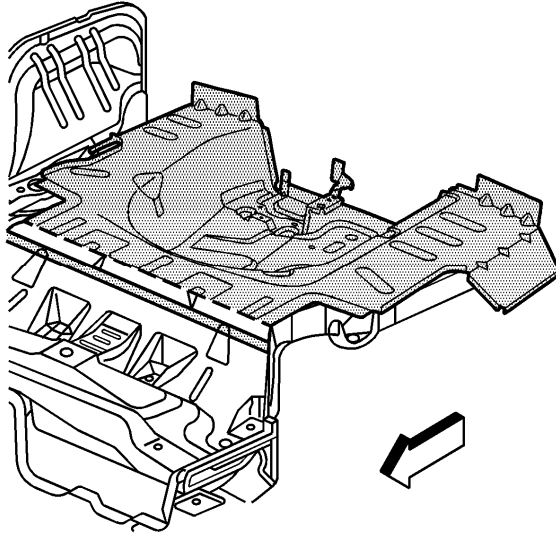

2. Place a piece of masking tape along the top radius within this transition area across the panel

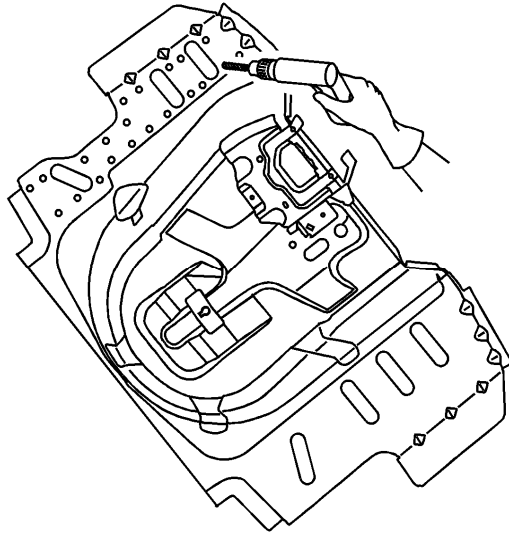

3. Cut along the forward edge of the tape, the edge that would be closest to the rear seat, and remove the rear portion of the panel.
4. Drill 8-mm (5/16-in) plug weld holes in the service part as necessary in the corresponding locations noted on the original panel.
5. Lay out and drill 2 additional rows of 8-mm (5/16-in) plug weld holes on top of the #5 bar weld flanges.

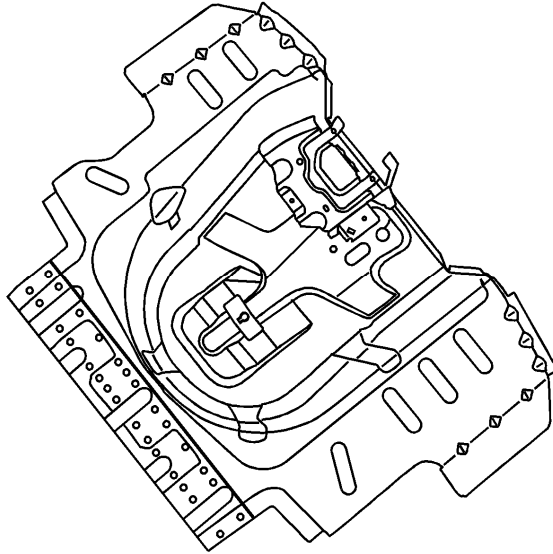

6. Prepare all mating surfaces for welding as necessary.
7. Apply GM-approved Weld-Thru Coating or equivalent to all mating surfaces. Refer to [Anti-Corrosion Treatment and Repair](#).
8. Position the rear floor pan to the vehicle using 3-dimensional measuring equipment. Clamp the part in place.
9. Plug weld accordingly.
10. Weld the seam along the front cut edge of the floor panel service part. To create a solid weld along the front of the service part with a minimum of heat distortion , make a stitch weld along the seam with 25 mm (1 in) gaps between each weld.
11. Clean and prepare all welded surfaces.
12. Apply sound deadening materials as necessary.
13. Paint the repaired area. Refer to [Basecoat/Clearcoat Paint Systems](#) in Paint and Coatings.

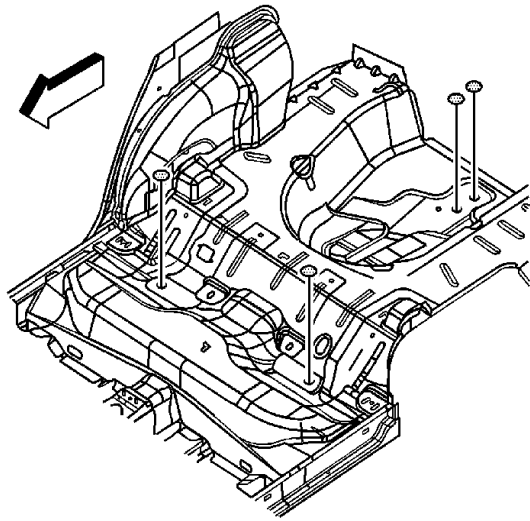

14. Apply the sealers and anti-corrosion materials to the repair area, as necessary.  
Refer to [Anti-Corrosion Treatment and Repair](#) in Paint and Coatings.
15. Install all related panels and components.
16. Connect the negative battery cable. Refer to [Battery Negative Cable Disconnect/Connect Procedure](#) in Engine Electrical.
17. Enable the SIR system. Refer to [SIR Disabling and Enabling Zones](#) in SIR.