

# Rear Window Panel Rear Reinforcement Replacement

## Removal Procedure

**Caution:** Refer to [Approved Equipment for Collision Repair Caution](#) in Cautions and Notices.

1. Disable the SIR system. Refer to [SIR Disabling and Enabling](#) in SIR.
2. Disconnect the negative battery cable. Refer to [Battery Negative Cable Disconnection and Connection](#) in Engine Electrical.
3. Remove all related panels and components.
4. Repair as much of the damaged area as possible. Refer to [Dimensions - Body](#) .
5. Remove the sealers and anti-corrosion materials from the repair area, as necessary. Refer to [Anti-Corrosion Treatment and Repair](#) in Paint and Coatings.

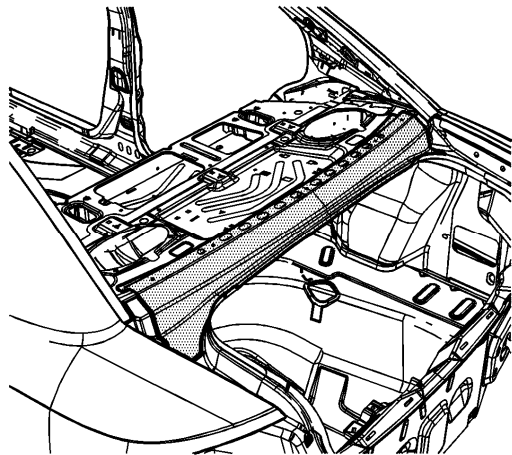

**Important:** Note the number and location of the factory welds for installation of the rear enforcement to the rear window panel.

6. Locate and drill out all the necessary factory welds.

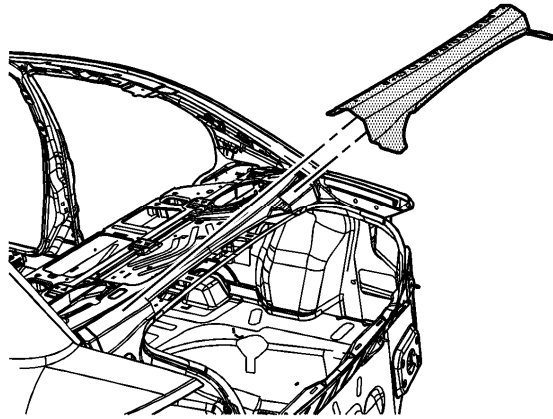

7. Remove the rear reinforcement to the rear window panel.

### Installation Procedure

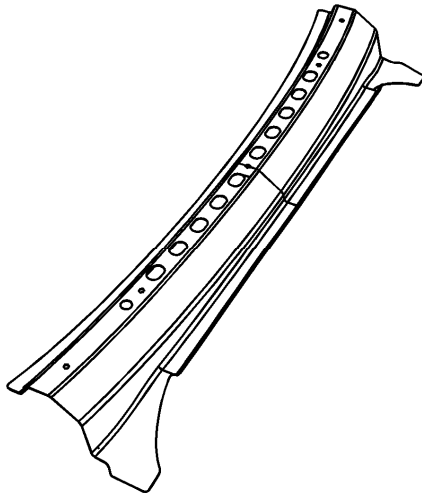

**Important:** If the location of the original plug weld holes can not be determined, space the plug weld holes every 40 mm (1½ in) apart.

1. Drill 8-mm (5/16-in) plug weld holes in the service part as necessary in the corresponding locations noted on the original panel.
2. Prepare all mating surfaces for welding as necessary.
3. Apply GM-approved Weld-Thru Coating or equivalent to all mating surfaces. Refer to [Anti-Corrosion Treatment and Repair](#).

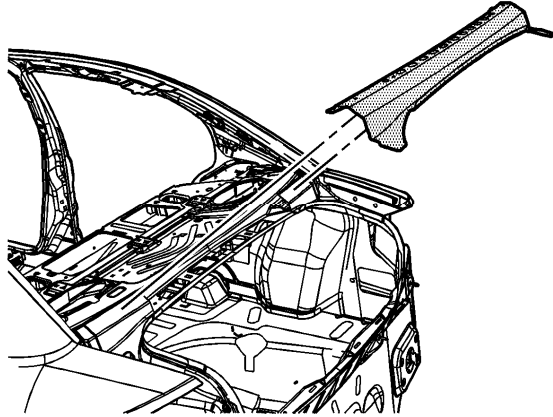

4. Position the rear enforcement to the rear window panel.

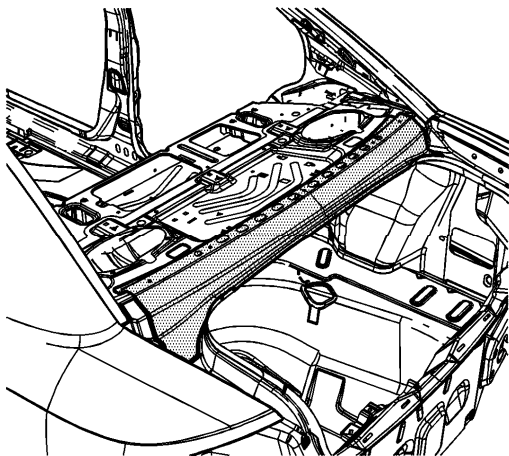

5. Plug weld accordingly.
6. Clean and prepare all of the welded surfaces.
7. Install all of the related panels and components.
8. Apply the sealers and anti-corrosion materials to the repair area, as necessary. Refer to [Anti-Corrosion Treatment and Repair](#) in Paint and Coatings.

9. Paint the repaired area. Refer to [Basecoat/Clearcoat Paint Systems](#) in Paint and Coatings.
10. Connect the negative battery cable. Refer to [Battery Negative Cable Disconnection and Connection](#) in Engine Electrical.
11. Enable the SIR system. Refer to [SIR Disabling and Enabling](#) in SIR.