

Pickup Box Assembly Replacement - Side

Removal Procedure

Caution: To avoid personal injury when exposed to welding flashes or to galvanized (Zinc Oxide) metal toxic fumes while grinding/cutting on any type of metal or sheet molded compound, you must work in a properly ventilated area, wearing an approved respirator, eye protection, earplugs, welding gloves, and protective clothing.

1. Remove the box assembly.
2. Remove the end gate.
3. Remove the wheelhouse liner.
4. Remove the tail lamp.
5. Restore as much damage as possible.
6. Note the location and remove the sealers and anti-corrosion materials from the repair area, as necessary. Refer to *Anti-Corrosion Treatment and Repair* on page 1-5 in General Information.
7. Note the location of all spot welds to be drilled out.
8. Locate and drill out spot welds on the inside of the panel.
9. Locate and drill out spot welds on the lower wheelhouse panel and lower rear post to the rear sill.

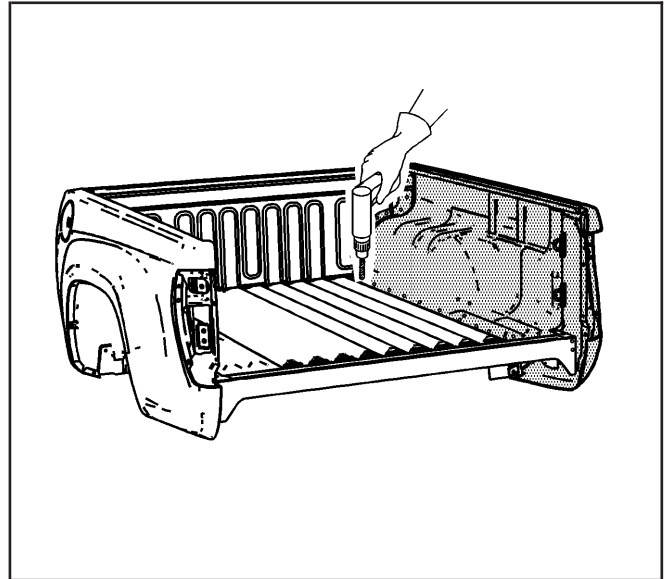

1237643

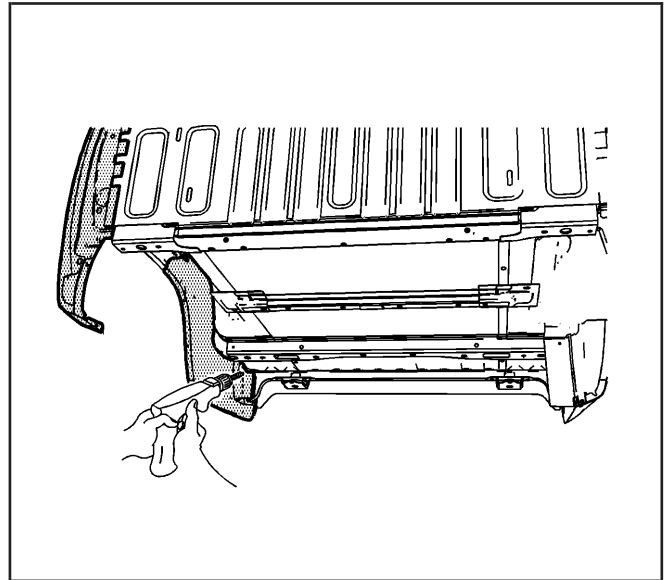

1305946

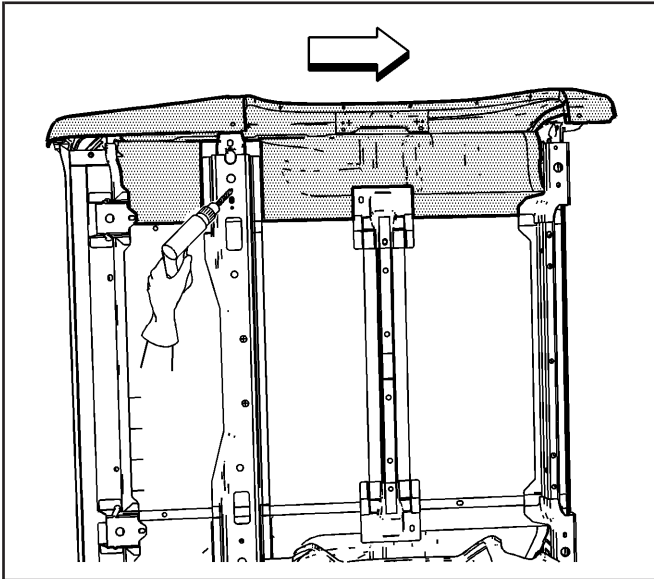

1306025

10. Locate and drill out spot welds that attach the cross sill to the sill extension.

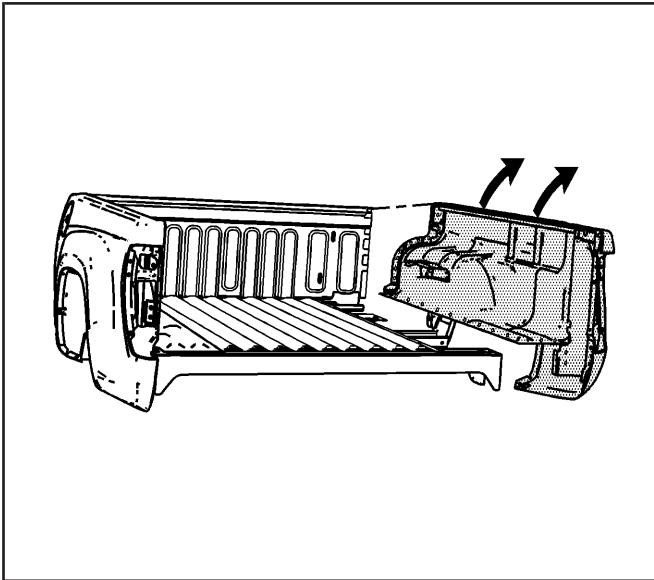

1239108

11. Remove the side panel.

Installation Procedure

1. Prepare all welded surfaces as necessary.
2. Apply 3M Weld-Thru Coating, P/N 05916 or equivalent to all mating surfaces.
3. Drill 8 mm (5/16 in) plug weld holes in the service part as noted.
4. Position the service part on to the bed assembly.

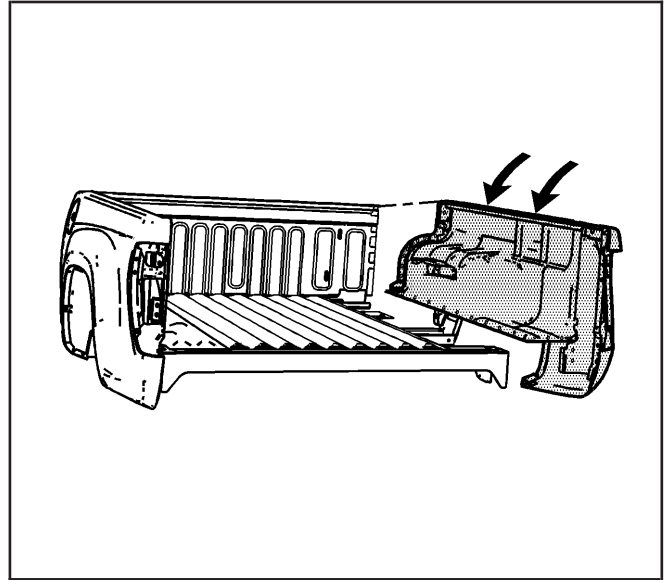

1239256

5. Plug the weld inside of the service part.

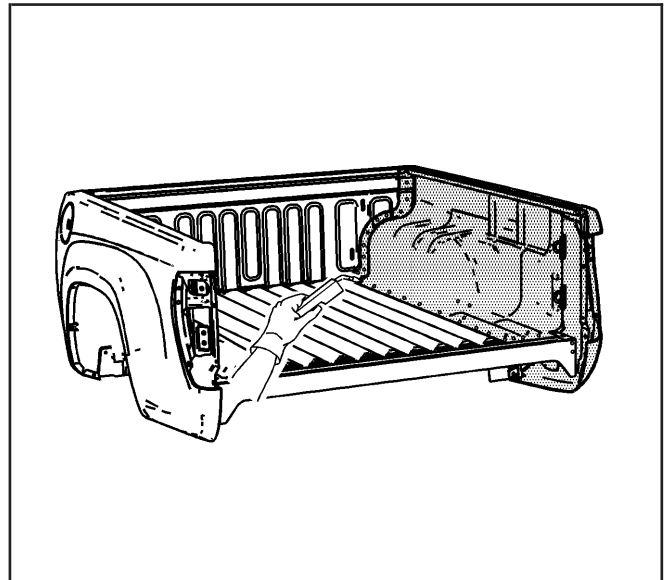

1238529

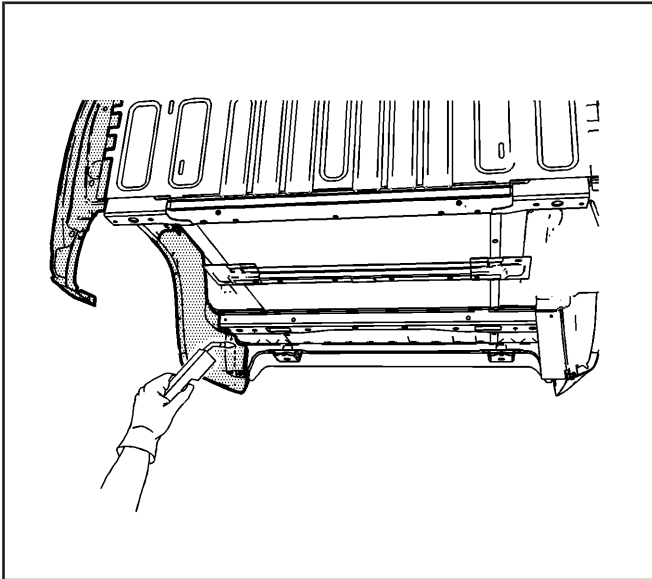

1306022

6. Plug the weld lower wheelhouse and the lower rear post to the rear sill.

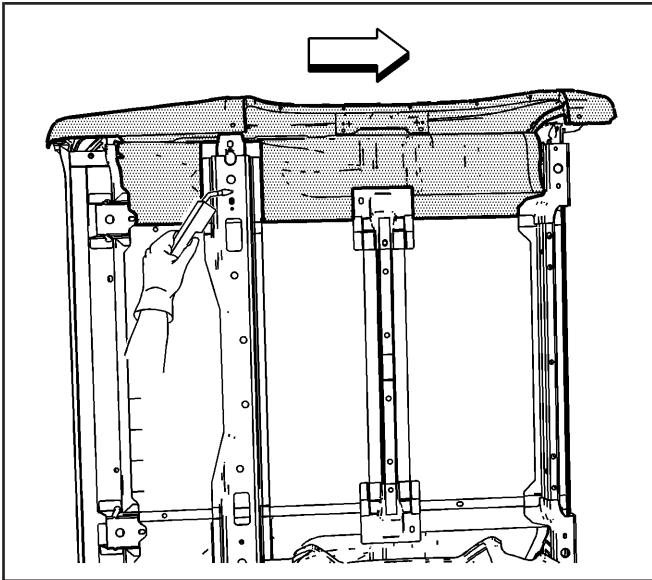

1306027

7. Plug the weld cross sill to the sill extension.
8. Clean and prepare all welded surfaces.
9. Apply the sealers and anti-corrosion materials to the repair area, as necessary. Refer to *Anti-Corrosion Treatment and Repair on page 1-5* in General Information.
10. Paint and repair the area. Refer to *Basecoat/Clearcoat Paint Systems on page 1-7* in General Information.
11. Install the wheelhouse liner.
12. Install the tail lamp.
13. Install the end gate.
14. Install the box assembly.