

Pickup Box Cross Sill Replacement - Rear

Removal Procedure

Caution: To avoid personal injury when exposed to welding flashes or to galvanized (Zinc Oxide) metal toxic fumes while grinding/cutting on any type of metal or sheet molded compound, you must work in a properly ventilated area, wearing an approved respirator, eye protection, earplugs, welding gloves, and protective clothing.

1. Remove the box assembly.
2. Remove the end gate.
3. Restore as much damage as possible.
4. Note the location and remove the sealers and anti-corrosion materials from the repair area, as necessary. Refer to *Anti-Corrosion Treatment and Repair* on page 1-5 in General Information.
5. Locate and drill out all factor spot welds. Note the number and location of the welds for installation of the service part.
6. Remove the rear sill from the pickup box.

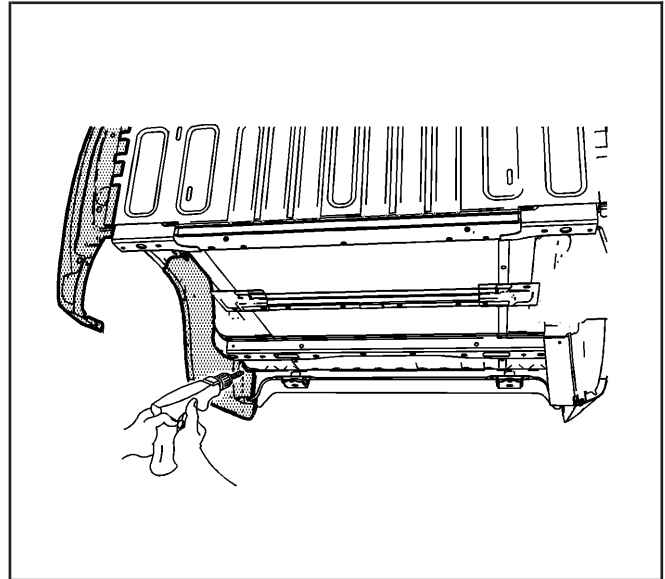

1305946

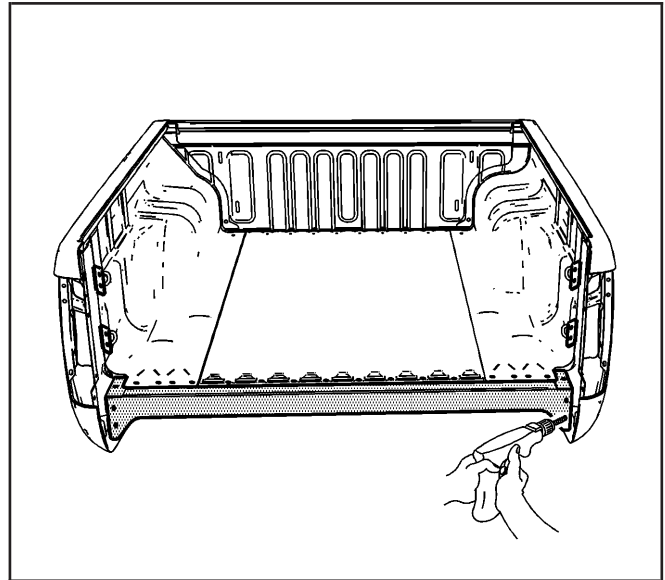

1305838

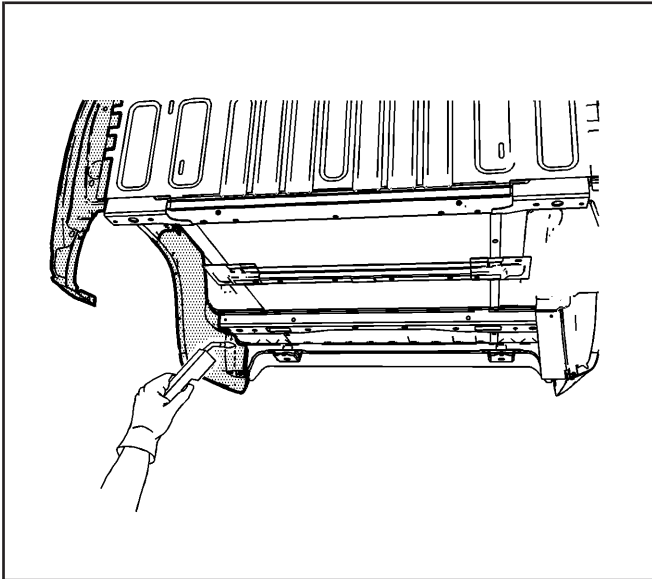

1306022

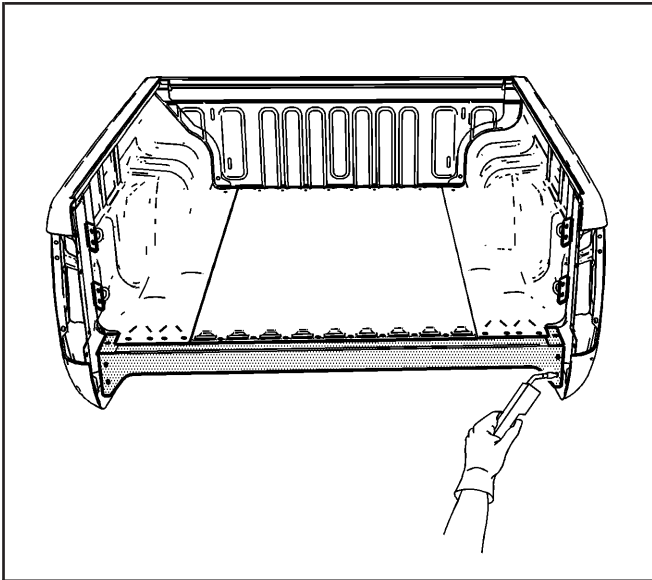

1305840

Installation Procedure

1. Prepare all mating surfaces as necessary.
2. Apply 3M Weld-Thru Coating, P/N 05916 or equivalent to all mating surfaces.
3. Align the service part to the pickup box.
4. Plug the weld accordingly.
5. Clean and prepare all welded surfaces.
6. Apply the sealers and anti-corrosion materials to the repair area, as necessary. Refer to *Anti-Corrosion Treatment and Repair on page 1-5* in General Information.
7. Paint and repair the area. Refer to *Basecoat/Clearcoat Paint Systems on page 1-7* in General Information.
8. Install the end gate.
9. Install the box assembly.