

Back Body Pillar Inner Panel Reinforcement Replacement

Removal Procedure

Caution: Refer to [Approved Equipment for Collision Repair Caution](#) in Cautions and Notices.

1. Disable the SIR system. Refer to [SIR Disabling and Enabling Zones](#) .
2. Disconnect the negative battery cable. Refer to [Battery Negative Cable Disconnect/Connect Procedure](#) .

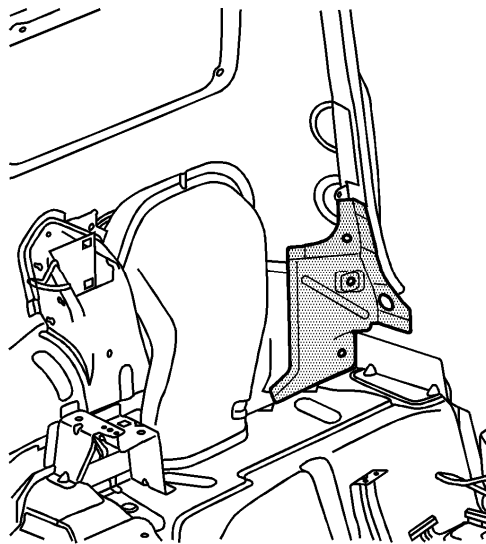

3. Remove all related panels and components.
4. Repair as much of the damage as possible. Refer to [Dimensions - Body](#) .
5. Remove the sealers and anti-corrosion materials from the repair area, as necessary. Refer to [Anti-Corrosion Treatment and Repair](#) .

Important: Note the number and location of the factory welds for installation of the impact bar bracket - front bumper

6. Locate and drill out all the factory spot welds.

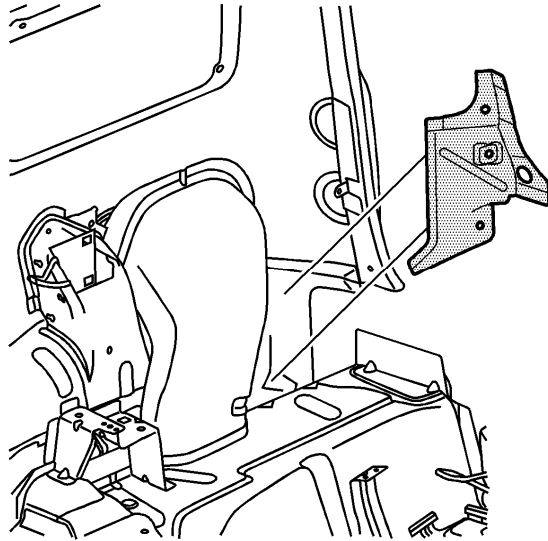

7. Remove the rear pillar inner reinforcement.

[Installation Procedure](#)

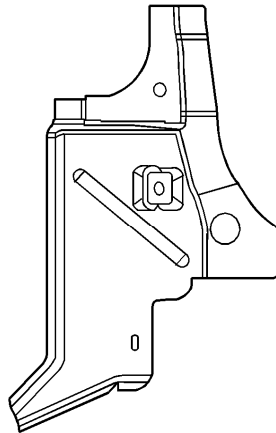

1. Prepare all mating surfaces as necessary.
2. Apply GM-approved Weld-Thru Coating or equivalent to all mating surfaces.
Refer to [Anti-Corrosion Treatment and Repair](#) .

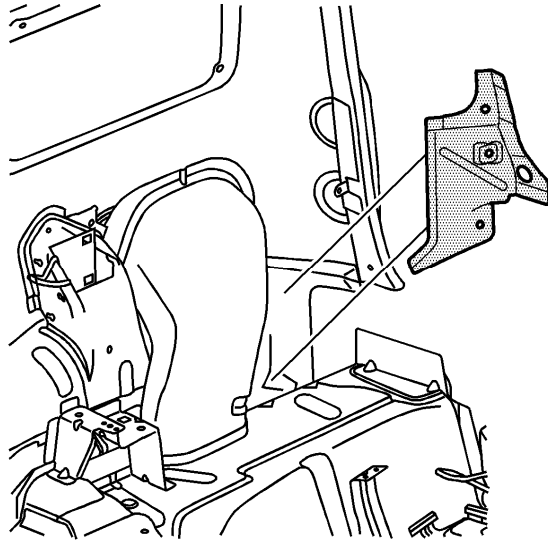

Important: Verify the location of the rear pillar inner reinforcement using 3-dimensional measuring equipment.

3. Position the rear pillar inner reinforcement on the vehicle and clamp in place.

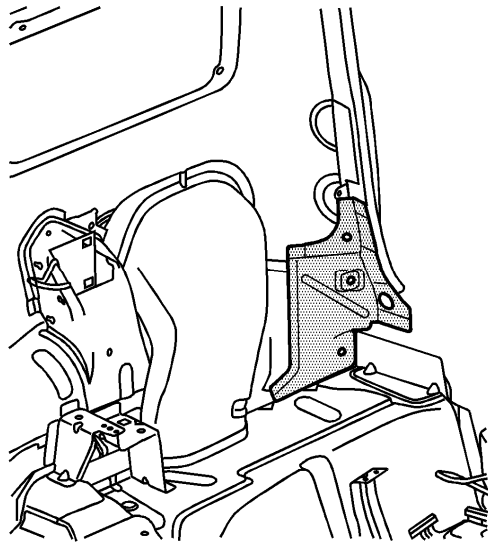

4. Plug weld accordingly.
5. Clean and prepare all of the welded surfaces.
6. Install all of the related panels and components.
7. Apply the sealers and anti-corrosion materials to the repair area, as necessary. Refer to [Anti-Corrosion Treatment and Repair](#) .
8. Paint the repaired area. Refer to [Basecoat/Clearcoat Paint Systems](#) .

9. Connect the negative battery cable. Refer to [Battery Negative Cable Disconnect/Connect Procedure](#) .
10. Enable the SIR system. Refer to [SIR Disabling and Enabling Zones](#) .