

Battery Tray Replacement

Removal Procedure

Caution: Refer to [Approved Equipment for Collision Repair Caution](#) in Cautions and Notices.

1. Disable the SIR system. Refer to [SIR Disabling and Enabling Zones](#) .
2. Disconnect the negative battery cable. Refer to [Battery Negative Cable Disconnect/Connect Procedure](#) .

Important: This panel is replaced at factory seams.

3. Remove all related panels and components.
4. Repair as much of the damaged area as possible. Refer to [Dimensions - Body](#) .
5. Remove the sealers and anti-corrosion materials from the repair area, as necessary. Refer to [Anti-Corrosion Treatment and Repair](#) .

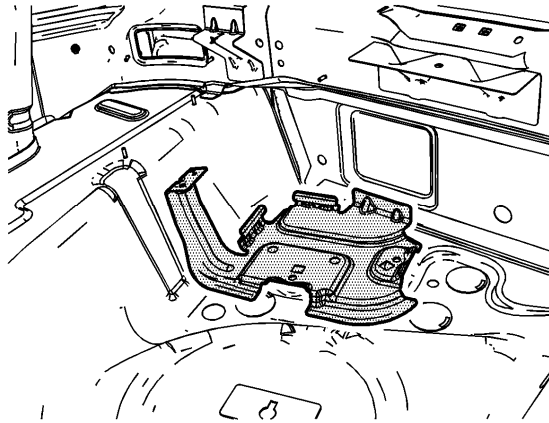

6. Locate and drill out all the necessary factory welds.

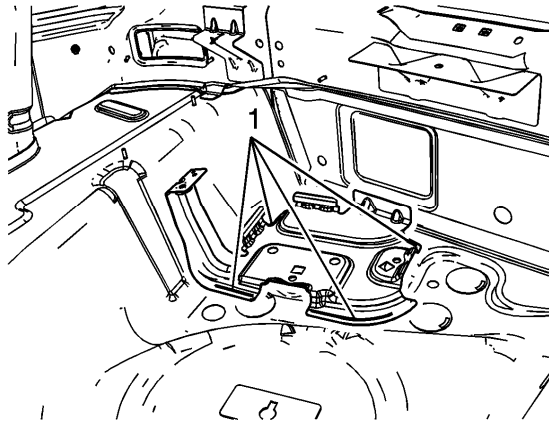

7. Structural adhesive is present at the joint between the battery tray and the rear floor pan. Heat the battery tray at the locations shown with a small flame from an oxy-acetylene torch to release the bond to the rear floor panel.

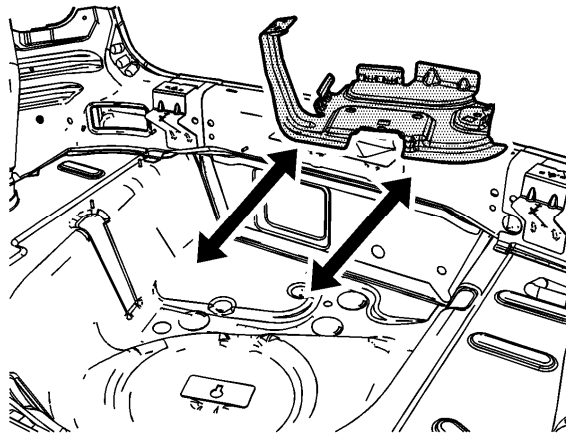

8. Remove the battery tray.

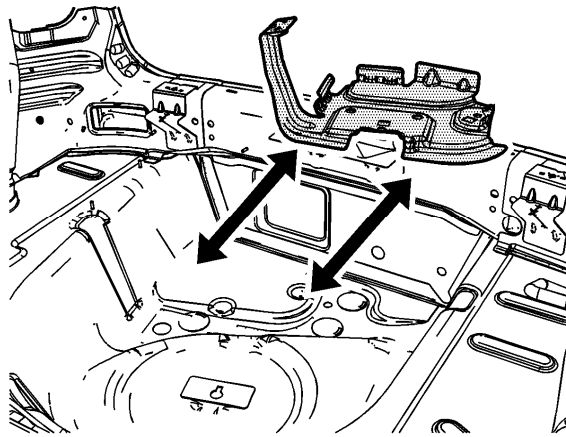

Important: The original battery tray has spot welds and bonding adhesive, but the service panel replacement will be MIG plug welded back together. Double the amount of factory welds in place of using the adhesive.

1. Drill 8 mm (5/16 in) plug weld holes in the service part as necessary in the locations noted from the original panel.
2. Prepare all mating surfaces for welding as necessary.
3. Apply GM-approved Weld-Thru Coating or equivalent to all mating surfaces. Refer to [Anti-Corrosion Treatment and Repair](#) .
4. Position the battery tray to the vehicle. Clamp the battery tray in place.
5. Plug weld accordingly.
6. Clean and prepare all of the welded surfaces.
7. Install all of the related panels and components.
8. Apply the sealers and anti-corrosion materials to the repair area, as necessary. Refer to [Anti-Corrosion Treatment and Repair](#) .
9. Paint the repaired area. Refer to [Basecoat/Clearcoat Paint Systems](#) .
10. Connect the negative battery cable. Refer to [Battery Negative Cable Disconnect/Connect Procedure](#) .
11. Enable the SIR system. Refer to [SIR Disabling and Enabling Zones](#) .