

Body Lock Pillar Outer Panel Sectioning

Removal Procedure

Caution: Refer to [Approved Equipment for Collision Repair Caution](#) in Cautions and Notices.

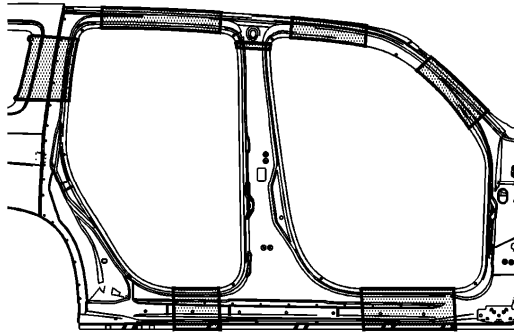

Caution: Sectioning should be performed only in the recommended areas. Failure to do so may compromise the structural integrity of the vehicle and cause personal injury if the vehicle is in a collision.

1. The body side outer panel is a one-piece assembly. You can perform any one of these replacement procedures separately or in any combination, depending upon the extent of the damage to the vehicle. Sectioning must take place in specified areas only.
2. Remove all related panels and components.
3. Disable the SIR system. Refer to [SIR Disabling and Enabling](#) .
4. Disconnect the negative battery cable. Refer to [Battery Negative Cable Disconnection and Connection](#) .

5. Remove the sealers and anti-corrosion materials from the repair area, as necessary and note their location. Refer to [Anti-Corrosion Treatment and Repair](#) .
6. Repair as much of the damaged area as possible. Refer to [Dimensions - Body](#) .

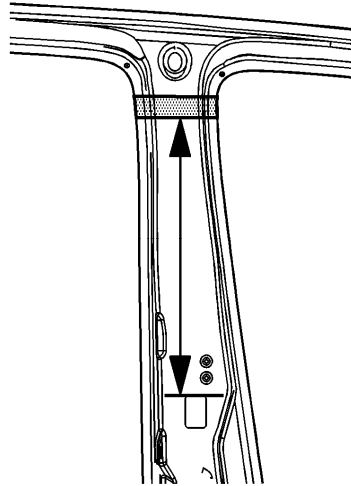

Important: The next 2 steps will create a sectioning zone of 45 mm (1.75 in) for the top portion of the pillar.

7. Measure straight up from the top of the square hole in the center pillar 495 mm (19 in) and mark the location of the measurement.

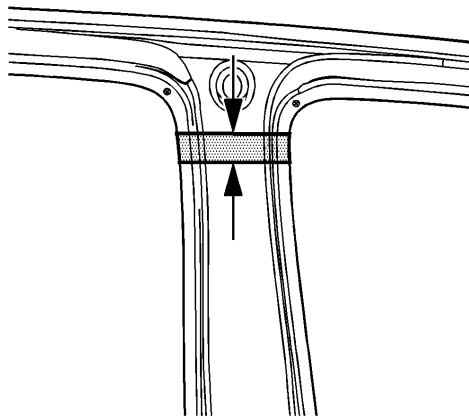

8. Measure up 45 mm (1.75 in) from the mark created in the previous step. Mark location of measurement.

9. Within the zone at the top of the pillar, measure and mark your required cut line. Make note of this measurement and use for service part cut line location.

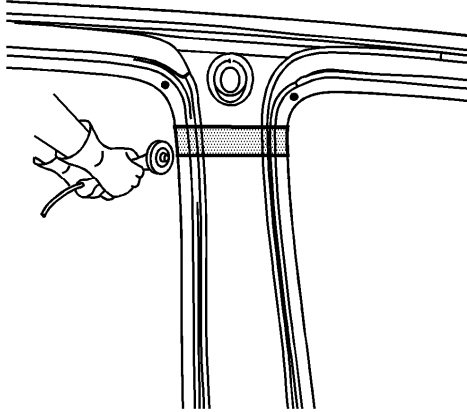

10. Cut the top area of the center pillar where the lay out line was previously formed.

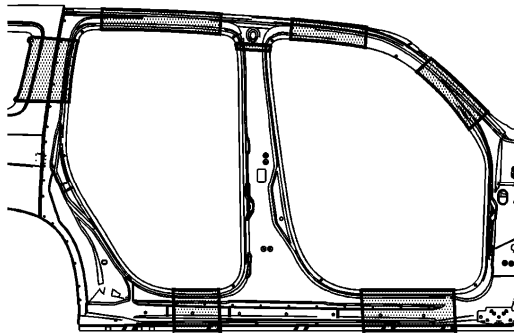

Important: Sectioning procedures can only take place in the straight areas of the body side panel.

11. Measure from any key feature in the panel. Lay out the cut line location on the body side panel within the approved section locations along rocker within the front and rear door openings as needed. Make note of this measurement and use for service part cut line location.

12. Mark measured location within sectioning zones in both front and rear door opening locations.

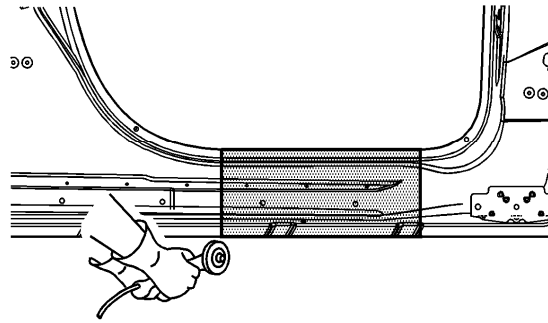

13. Cut the panel at the front door opening of the rocker panel area where sectioning is to be performed, within the straight sections only.

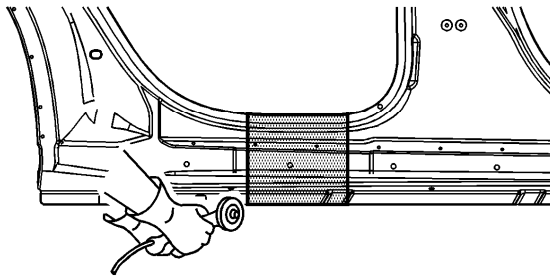

14. Cut the panel at the rear door opening of the rocker panel area where sectioning is to be performed within the straight sections only.
15. Locate and drill out all factory welds. Note the number and location of welds for installation of the service part.

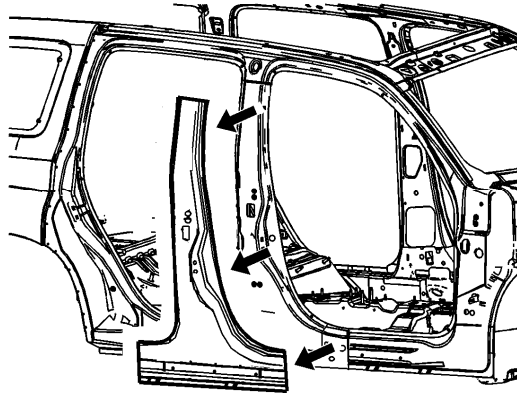

16. Remove the damaged center pillar.

Installation Procedure

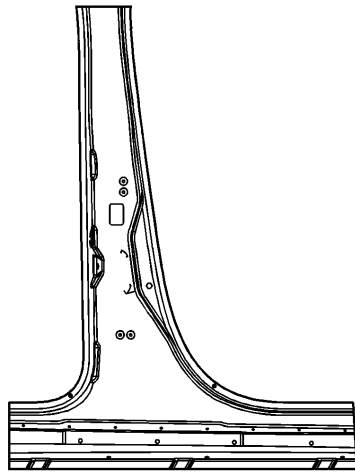

1. Cut the outer center pillar service panel in corresponding locations to fit the remaining original panel. The sectioning joint should be trimmed to allow a gap of $1\frac{1}{2}$ times the metal thickness at the sectioning joint.

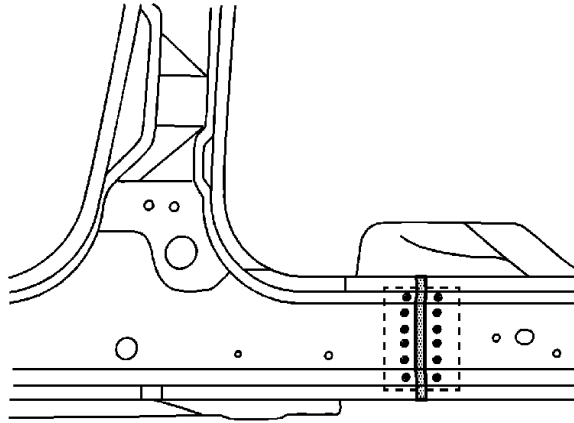

2. In all the rocker panel areas, create a 100 mm (4 in) backing plate from the unused portion of the service part. Trim the backing plates as necessary to fit behind the sectioning joint.

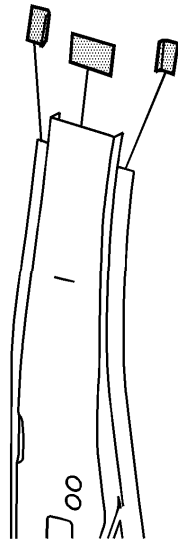

Important: The reinforcement in top of pillar sectioning area fits tight to outer panel. Reinforcement in center area of sectioning joint will be utilized as a welding backer. See illustration for service part joint preparation.

3. In the upper center pillar area, the joint will be a 25 mm (1 in) overlap. Special attention to joint fit up and cutting is necessary with this area of the repair.

Important: If the location of the original plug weld holes can not be determined, space the plug weld holes every 40 mm (1½ in) apart.

4. Drill 8 mm (5/16 in) holes along the sectioning area on the service and original part. Locate these holes 13 mm (1/2 in) from the edge.
5. Drill 8 mm (5/16 in) plug weld holes in the service part as necessary in the corresponding locations noted on the original panel.
6. Prepare all mating surfaces for welding as necessary.
7. Apply GM-approved Weld-Thru Coating or equivalent to all mating surfaces. Refer to [Anti-Corrosion Treatment and Repair](#) .
8. Clamp the backing plates in place. Plug weld the backing plates to the vehicle.

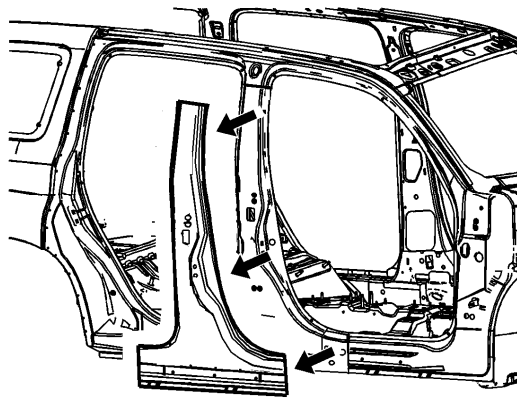

9. Position the outer center pillar to the vehicle using 3-dimensional measuring equipment. Clamp the pillar in place.
10. Plug weld accordingly.
11. To create a solid weld with minimum heat distortion, make a 25 mm (1 in) stitch weld along the seam with gaps of 25 mm (1 in). Go back and complete the stitch weld.
12. Clean and prepare all of the welded surfaces.
13. Apply sound deadening materials as necessary.
14. Apply the sealers and anti-corrosion materials to the repair area, as necessary. Refer to [Anti-Corrosion Treatment and Repair](#) .
15. Paint the repaired area. Refer to [Basecoat/Clearcoat Paint Systems](#) .
16. Install all of the related panels and components.
17. Connect the negative battery cable. Refer to [Battery Negative Cable Disconnection and Connection](#) .
18. Enable the SIR system. Refer to [SIR Disabling and Enabling](#) .