

# Cross Bar No.4 Replacement - Floor Panel

## Removal Procedure

### **Caution**

Refer to [Approved Equipment for Collision Repair Caution](#) in Cautions and Notices.

1. Disable the SIR system. Refer to [SIR Disabling and Enabling Zones](#) in SIR.
2. Disconnect the negative battery cable. Refer to [Battery Negative Cable Disconnect/Connect Procedure](#) in Engine Electrical.
3. Remove all related panels and components.
4. Repair as much of the damaged area as possible. Refer to [Dimensions - Body](#) .
5. Remove the sealers and anti-corrosion materials from the repair area, as necessary. Refer to [Anti-Corrosion Treatment and Repair](#) in Paint and Coatings.

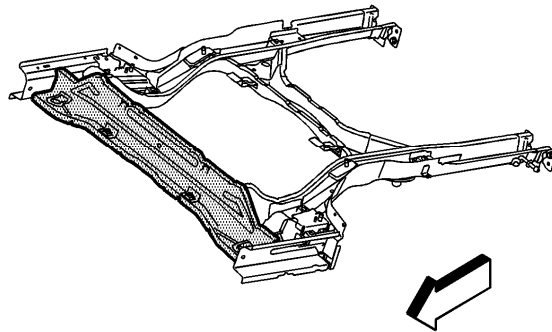

### **Important**

Note the number and location of the factory welds for installation of the #4 cross bar.

6. Locate and drill out all the necessary factory welds.

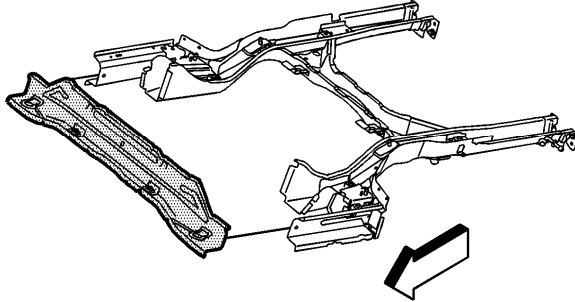

7. Remove the #4 cross bar.

### Installation Procedure

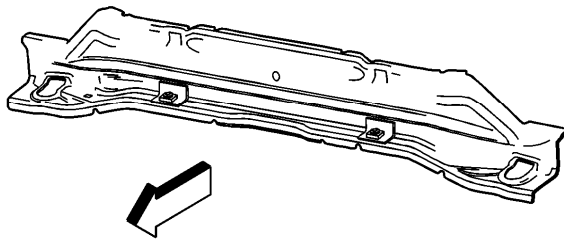

### **Important**

If the location of the original plug weld holes can not be determined, space the plug weld holes every 40 mm (1½ in) apart.

1. Drill 8 mm (5/16 in) plug weld holes in the service part as necessary in the locations noted from the original panel.
2. Prepare all mating surfaces for welding as necessary.
3. Apply GM-approved Weld-Thru Coating or equivalent to all mating surfaces. Refer to [Anti-Corrosion Treatment and Repair](#).

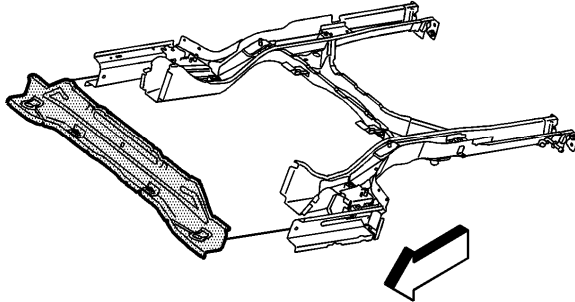

4. Position the #4 cross bar.

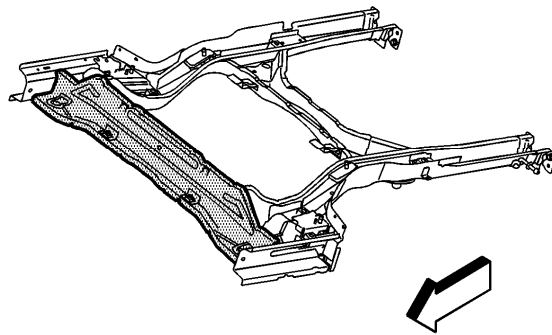

5. Plug weld accordingly.
6. Clean and prepare all of the welded surfaces.
7. Install all of the related panels and components.
8. Apply the sealers and anti-corrosion materials to the repair area, as necessary. Refer to [Anti-Corrosion Treatment and Repair](#) in Paint and Coatings.

9. Paint the repaired area. Refer to [Basecoat/Clearcoat Paint Systems](#) in Paint and Coatings.
10. Connect the negative battery cable. Refer to [Battery Negative Cable Disconnect/Connect Procedure](#) in Engine Electrical.
11. Enable the SIR system. Refer to [SIR Disabling and Enabling Zones](#) in SIR.