

# Front Hinge Pillar Body Sectioning

## Removal Procedure

**Caution:** Refer to [Approved Equipment for Collision Repair Caution](#) in Cautions and Notices.

**Caution:** Sectioning should be performed only in the recommended areas. Failure to do so may compromise the structural integrity of the vehicle and cause personal injury if the vehicle is in a collision.

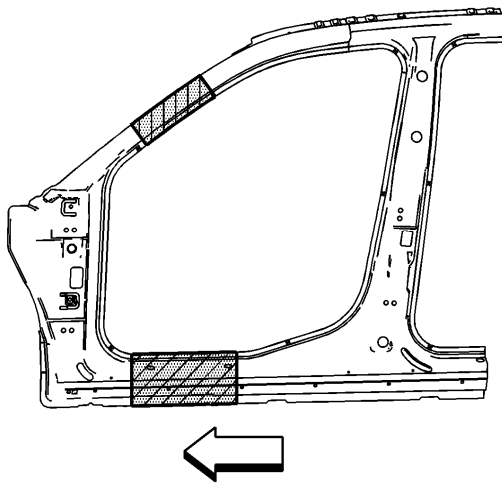

The sedan and extended sedan body side outer panel are available in one-piece side frames. You can perform any one of these replacement procedures separately or in any combination, depending upon the extent of damage to the vehicle. Sectioning must take place in specified areas only. Stay away from the door and window opening radius areas. Section only in straight areas of the openings.

1. Disable the SIR system. Refer to [SIR Disabling and Enabling](#) in SIR.
2. Disconnect the negative battery cable. Refer to [Battery Negative Cable Disconnection and Connection](#) in Engine Electrical.

3. Remove all related panels and components.
4. Repair as much of the damaged area as possible. Refer to [Dimensions - Body](#) .
5. Remove the sealers and anti-corrosion materials from the repair area, as necessary. Refer to [Anti-Corrosion Treatment and Repair](#) in Paint and Coatings.

**Important:** Sectioning can be done anywhere in the straight areas of the windshield pillar and along the rocker panel.

6. Locate the area on the panel where sectioning will be performed.

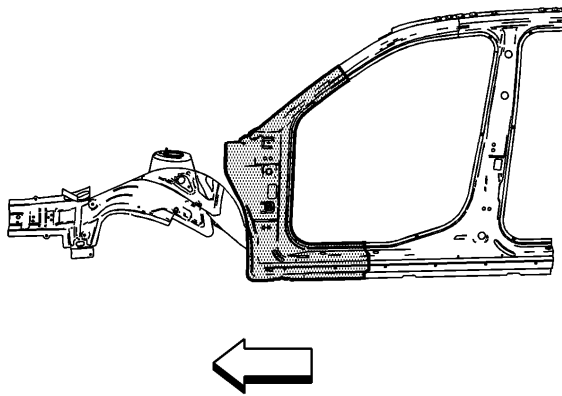

7. Measure from any trim attachment hole within the recommended sectioning areas. Mark the location for section cutting on the vehicle at the windshield pillar and rocker panel locations.

**Important:** Note the number and location of the factory welds for installation of the hinge pillar.

8. Locate and drill out all factory welds.

**Important:** Do NOT damage any other panels or reinforcements when cutting at the marked locations.

9. Cut the panel at the location laid out in the previous steps.

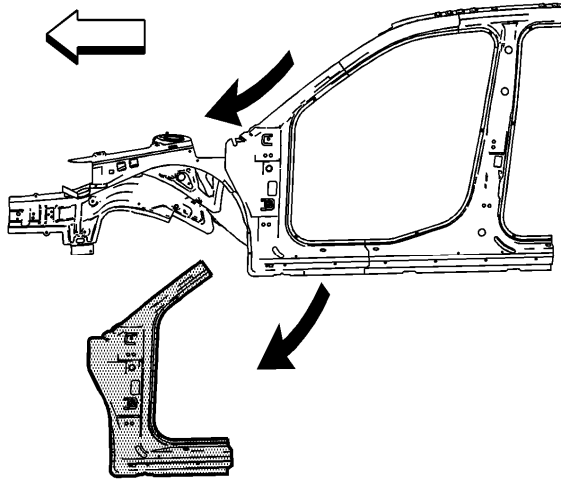

10. Remove the damaged hinge pillar.

### Installation Procedure

1. Locate the area on the service panel to be sectioned.
2. Measure and mark the cut line location on the service part at the same location as on the vehicle layout.

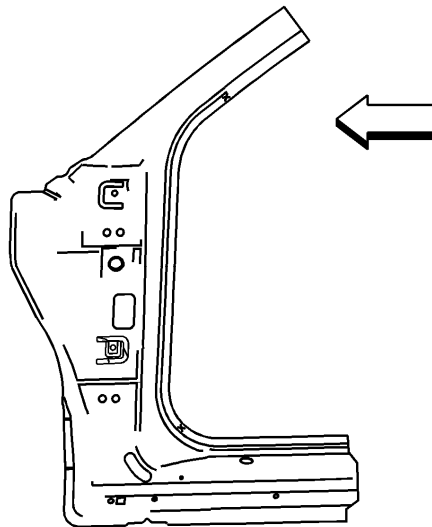

3. Cut the outer front hinge pillar in corresponding locations to fit the remaining original panel. The sectioning joint should be trimmed to allow a gap of 1½ times the metal thickness at the sectioning joint.

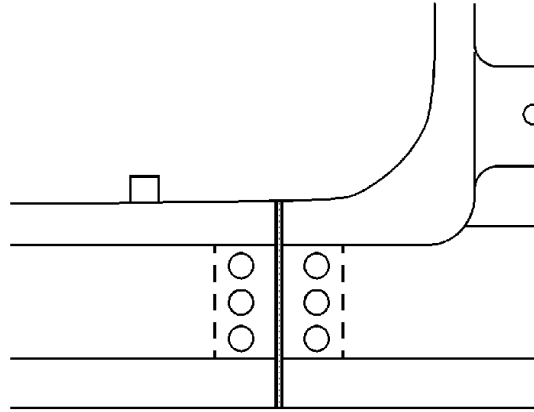

4. Create a 50 mm (2 in) backing plate from the unused portion of the service part for the windshield area.
5. Create a 100 mm (4 in) backing plate from the unused portion of the service part for the rocker area.
6. Trim the backing plates as necessary to fit behind the panel at the sectioning joint.

**Important:** If the location of the original plug weld holes can not be determined, space the plug weld holes every 40 mm (1 1/2 in) apart.

7. Drill 8 mm (5/16 in) plug weld holes along the sectioning area in the service part, and at the locations noted from the original panel.

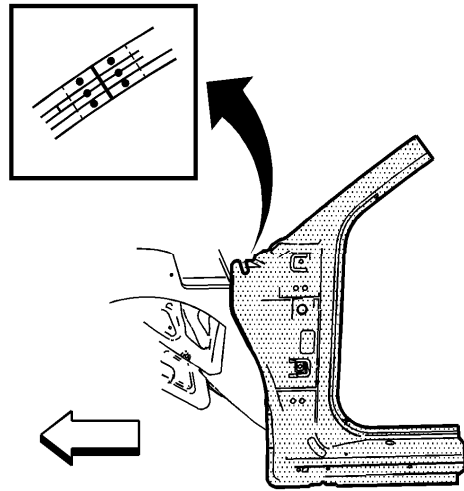

8. Prepare all mating surfaces as necessary.
9. Apply GM-approved Weld-Thru Coating or equivalent to all mating surfaces. Refer to [Anti-Corrosion Treatment and Repair](#).
10. Fit the backing plates halfway into the sectioning joints, 25 mm (1 in) at the windshield pillar and 50 mm (2 in) at the rocker panel areas. Clamp the plates in place, and plug weld to the section joint
11. Position the outer front pillar to the vehicle using 3-dimensional measuring equipment. Clamp the pillar in place.
12. Plug weld accordingly.

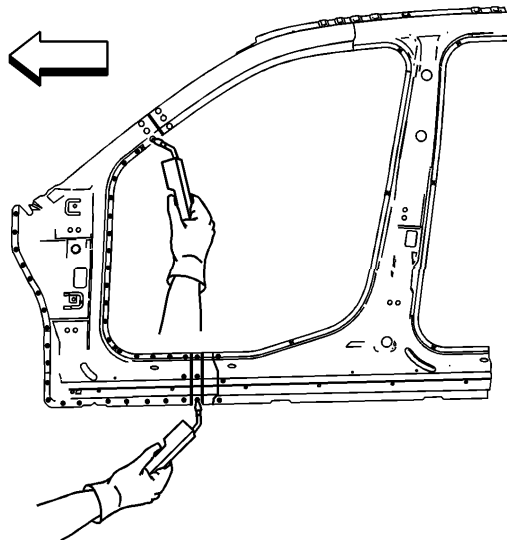

13. Plug weld accordingly.
14. Stitch weld the butt weld locations.

15. To create a solid weld with minimum heat distortion, make a 25 mm (1 in) stitch weld along the seam with gaps of 25 mm (1 in). Go back and complete the stitch weld.
16. Clean and prepare all of the welded surfaces.
17. Apply the sealers and anti-corrosion materials to the repair area, as necessary. Refer to [Anti-Corrosion Treatment and Repair](#) in Paint and Coatings.
18. Paint the repaired area. Refer to [Basecoat/Clearcoat Paint Systems](#) in Paint and Coatings.
19. Install all of the related panels and components.
20. Connect the negative battery cable. Refer to [Battery Negative Cable Disconnection and Connection](#) in Engine Electrical.
21. Enable the SIR system. Refer to [SIR Disabling and Enabling](#) in SIR.