

# Front Wheelhouse Replacement (Laminated Steel Dash)

## Removal Procedure

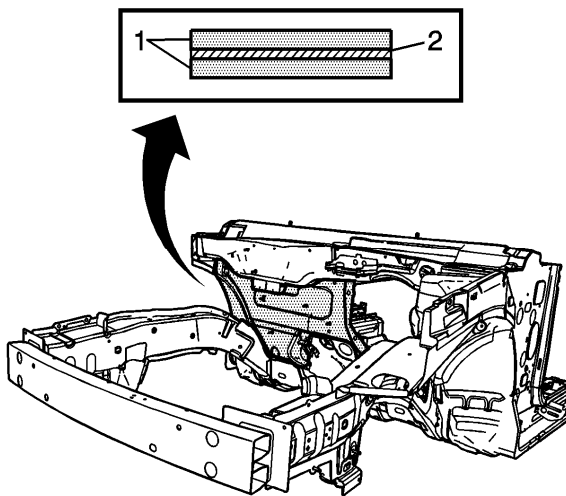

**Caution:** Refer to [Approved Equipment for Collision Repair Caution](#) in Cautions and Notices.

**Caution:** Refer to [Foam Sound Deadeners Caution](#) in Cautions and Notices.

### **Important:**

- Model year 2005 and prior vehicles are not manufactured with laminated steel in front of the dashes. Therefore, the front wheelhouse assembly can be metal inert gas (MIG) welded instead of the rivet and bonding process, as stated in these instructions.

The front of the dash panel is formed from laminated steel. This steel is constructed by bonding 2 pieces of cold rolled steel (1) with a viscoelastic layer of adhesive (2). MIG welding laminated steel does not meet GM Corporate standards for structural integrity. As an alternative, all factory welds will be replaced by using the rivet and

adhesive bond method described in the installation portion of this procedure. The rivet and adhesive bond method must only be used in the areas, as described in this procedure.

- Failure to follow this procedure will compromise the structural integrity of the vehicle.
1. Disable the SIR system. Refer to [SIR Disabling and Enabling](#) .
  2. Disconnect the negative battery cable. Refer to [Battery Negative Cable Disconnection and Connection](#) .

**Caution:** Refer to [Collision Sectioning Caution](#) in Cautions and Notices.

3. Remove all related panels and components.
4. Repair as much of the damage as possible.
5. Remove the sealers and the anti-corrosion materials from the repair area, as necessary. Refer to [Anti-Corrosion Treatment and Repair](#) .

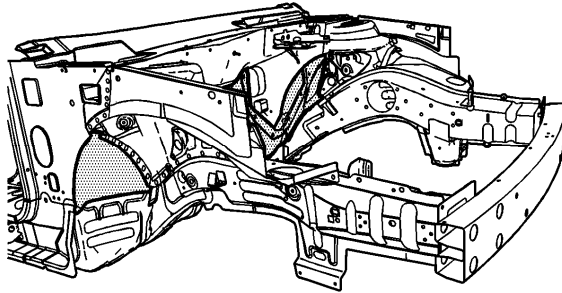

**Important:** Note the number and location of the factory welds for installation of the full wheelhouse service part.

6. Remove the radiator support assembly. Refer to [Radiator Support Replacement](#) .

7. Remove the upper fender rail. Refer to [Rail Replacement - Upper](#) .

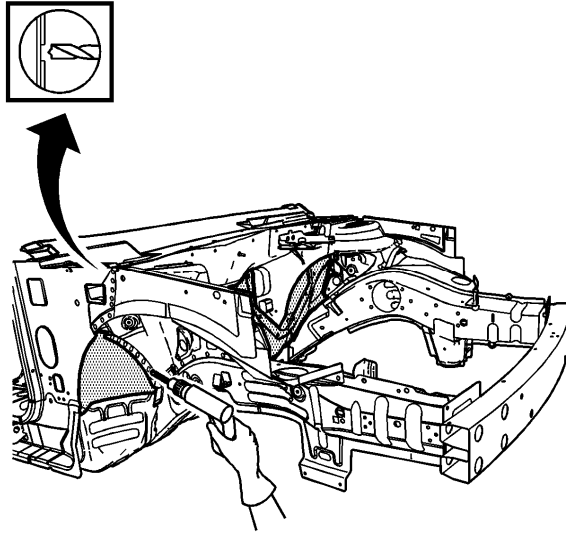

**Important:** Drill through the wheelhouse flange only. Do NOT drill into the dash panel or the inner reinforcements.

8. Using an 8-mm (5/16-in) spot weld remover, locate and drill out the factory welds on the weld flange connecting the wheelhouse to the dash panel.

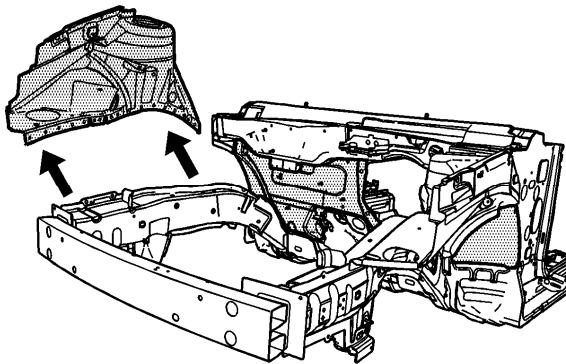

9. Remove the wheelhouse.

## Installation Procedure

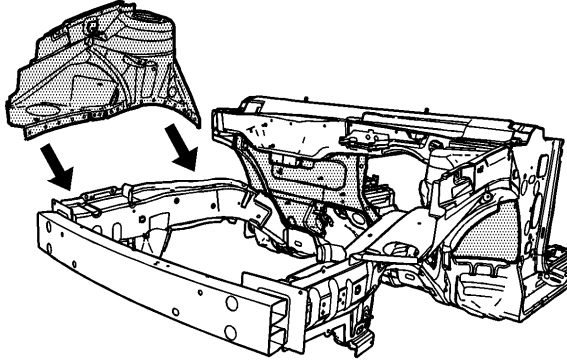

1. Position the service wheelhouse to the vehicle using 3-dimensional measuring equipment.
2. Clamp the wheelhouse in place.

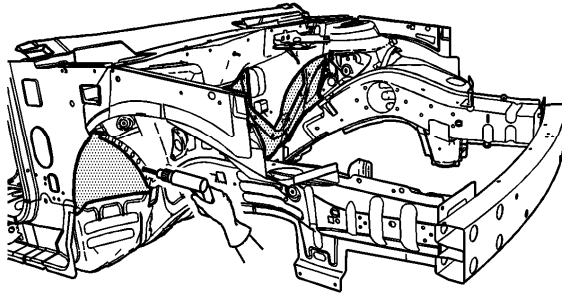

3. Using a 7-mm (17/64-in) bit, drill the rivet attachment holes through the service wheelhouse and the dash panel, in the exact locations as noted from the factory

wheelhouse.

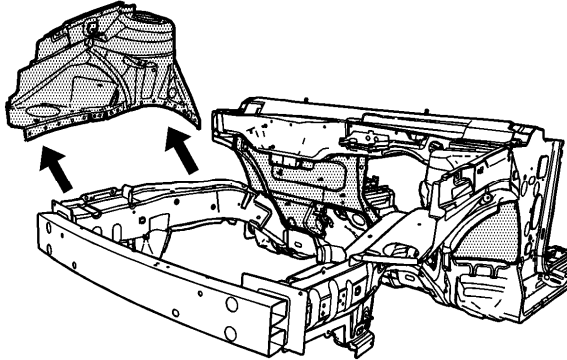

4. Remove the service wheelhouse.

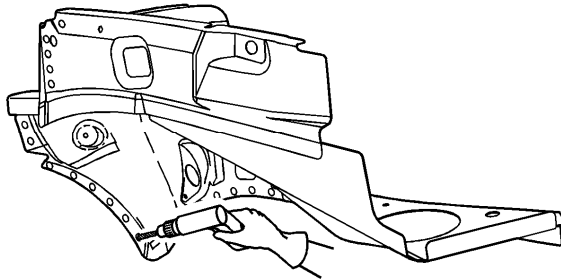

**Important:** If the location of the original plug weld holes cannot be determined, space the plug weld holes every 40 mm (1.5 in) apart.

5. Drill 8-mm (5/16-in) plug weld holes in the service wheelhouse, as necessary, in the remaining locations noted from the original wheelhouse.
6. Prepare the plug weld mating surfaces, as necessary.
7. Apply GM-approved Weld-Thru Coating or equivalent to all mating surfaces. Refer to [Anti-Corrosion Treatment and Repair](#).

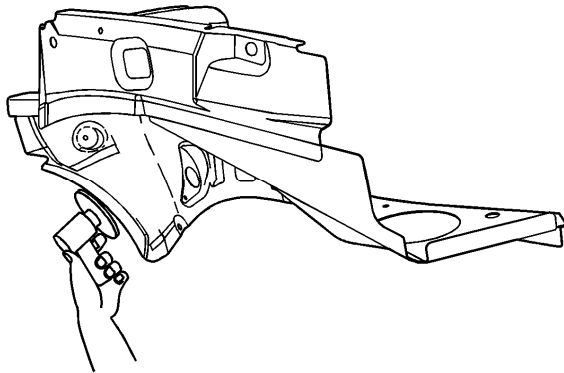

8. Prepare the bond mating areas by grinding the body mating and the service part flanges to bare steel. Do NOT damage the corners or thin the metal during the grinding process.
9. Clean the mating surfaces.

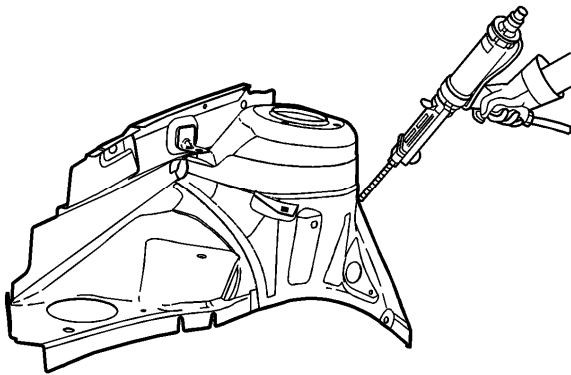

**Important:** The adhesive has a 40-50 minute working time. Do NOT allow the adhesive to cure prior to installing the service wheelhouse.

10. Apply a 3-6 mm (1/8 to 1/4 in) bead of metal panel bonding adhesive GM P/N 12378567 (Canadian P/N 88901675) or equivalent to both of the mating surfaces.

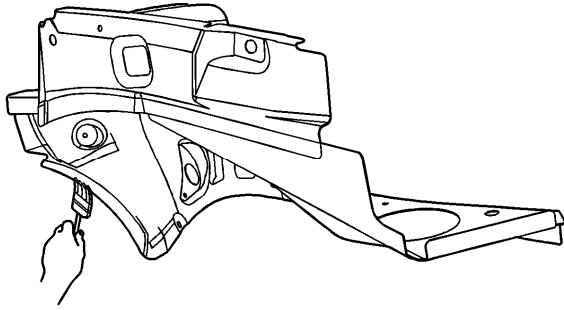

11. Using a small acid brush, spread a coat of adhesive to both of the mating surfaces. Cover all of the bare metal to ensure corrosion protection.

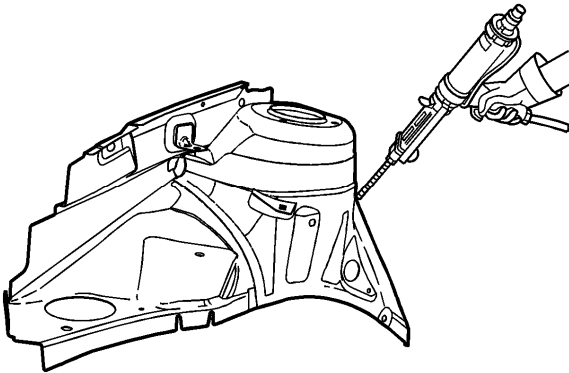

12. Apply a 3-6 mm (1/8 to 1/4 in) bead of metal panel bonding adhesive GM P/N 12378567 (Canadian P/N 88901675) or equivalent to the mating surface of the service wheelhouse.

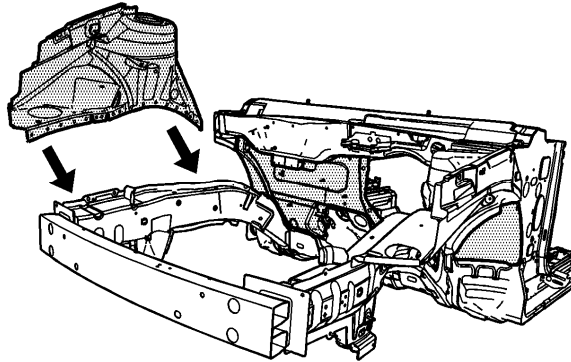

**Important:** Do NOT pull the wheelhouse off of the dash after adhesion. To align the parts, slide the wheelhouse against the front of the dash.

13. Position the service wheelhouse to the vehicle using 3-dimensional measuring equipment.
14. Clamp the wheelhouse in place.

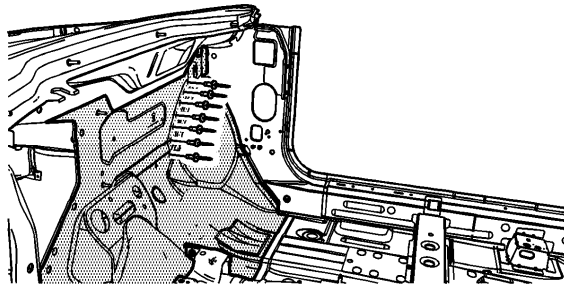

**Important:** Verify proper positioning of the service wheelhouse prior to riveting and welding.

15. Install the 9 mm (11/32 in) long rivets so that the rivet head contacts the passenger compartment side of the dash.
16. Remove the excess adhesive from the wheelhouse area.

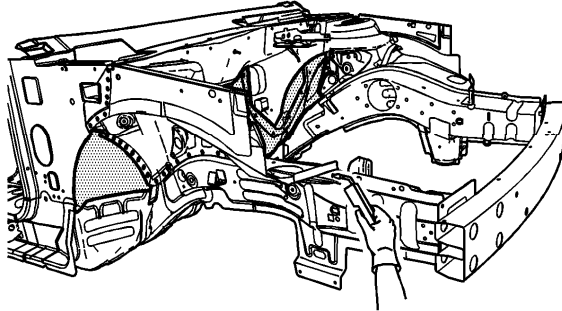

17. Plug weld the remaining holes accordingly.
18. Clean and prepare all of the welded surfaces.
19. Install the radiator support assembly. Refer to [Radiator Support Replacement](#) .
20. Install the upper fender rail. Refer to [Rail Replacement - Upper](#) .
21. Apply the sealers and anti-corrosion materials to the repaired area, as necessary. Refer to [Anti-Corrosion Treatment and Repair](#) .
22. Paint the repaired area. Refer to [Basecoat/Clearcoat Paint Systems](#) .
23. Install all of the related panels and components.
24. Connect the negative battery cable. Refer to [Battery Negative Cable Disconnection and Connection](#) .
25. Enable the SIR system. Refer to [SIR Disabling and Enabling](#) .