

Quarter Outer Panel Sectioning (Extended Sedan)

Description

This repair procedure gives you the option of using an installation procedure for either metal-inert gas (MIG) welding or adhesive bonding. The choice of installation depends on the type of application requirements. The adhesive bonding procedure may also require MIG welding in some areas of the repair.

Removal Procedure

Caution: Refer to [Approved Equipment for Collision Repair Caution](#) in Cautions and Notices.

Important: Before beginning the repair, refer to [Metal Panel Bonding](#) for proper adhesive preparations and general information.

1. Disconnect the negative battery cable. Refer to [Battery Negative Cable Disconnection and Connection](#) .
2. Disable the SIR system. Refer to [SIR Disabling and Enabling](#) .
3. Restore as much of the damage as possible to factory specifications. Refer to [Dimensions - Body](#) .
4. Remove all related panels and components.
5. Note the location and remove the sealers and anti-corrosion materials from the repair area, as necessary. Refer to [Anti-Corrosion Treatment and Repair](#) .

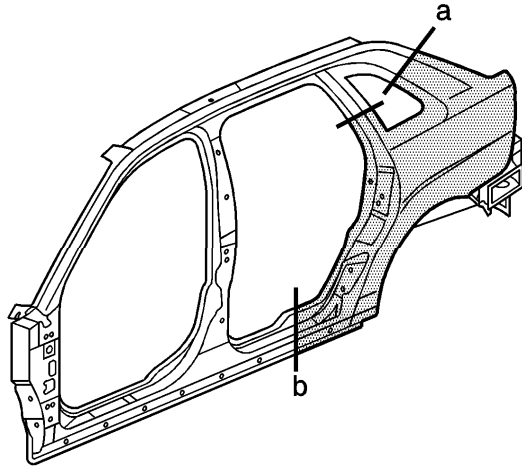

6. Section the sail panel (a) and the rocker panel (b).

- At the sail panel, measure from the back glass opening down 120 mm (4 3/4 in). Scribe a line.
- At the rocker panel, measure 70 mm (2 3/4 in) rearward from the rocker panel locating hole. Scribe a line.

8.

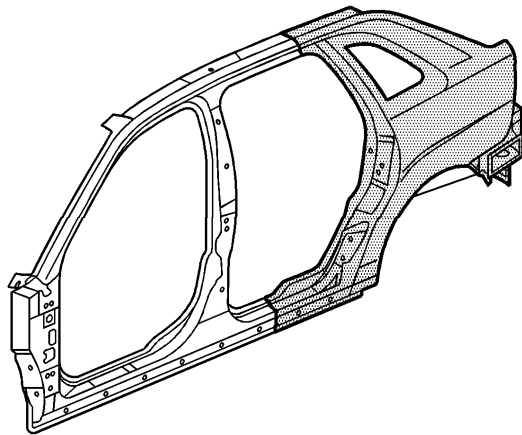

9. Locate and drill out all factory welds. Note the number and location of welds for installation of the quarter panel.

Important: Do not damage any other panel or reinforcements when cutting at the marked locations.

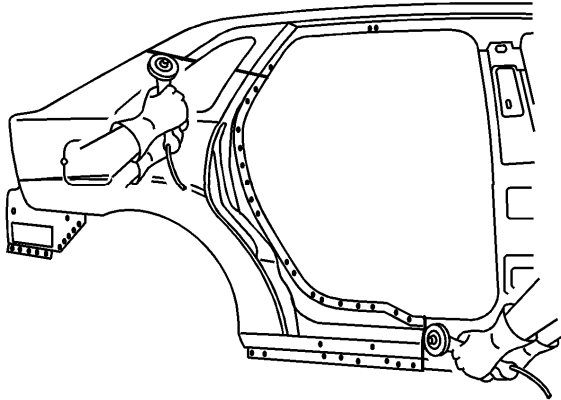

10. Cut the panel at the marked locations.

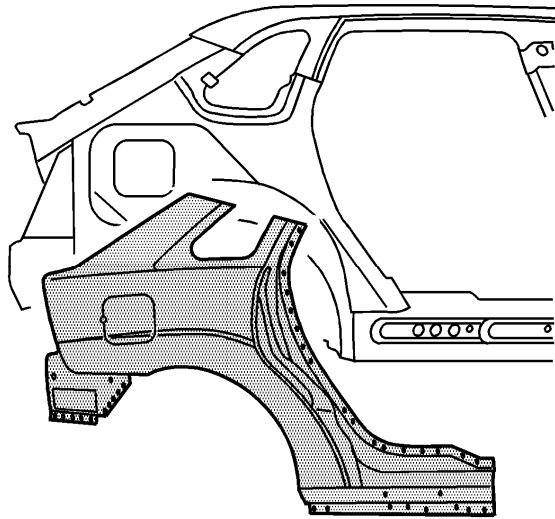

11. Remove the lower quarter panel.

Installation Procedure (Metal-Inert Gas (MIG) Welding)

Important: To allow proper layout and cutting of the service part, review the sectioning information in the removal procedure.

1. Locate the area on the service part where the sectioning will be performed.

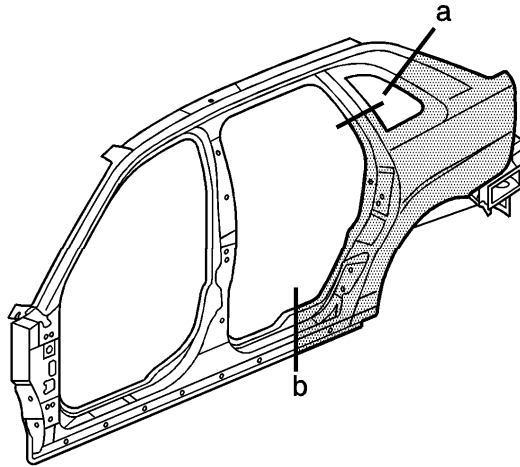

2. Measure and mark the cut line location on the service area.
3. Cut the service panel at the marked locations. Trim the sectioning butt joints to allow a gap equal to the metal thickness at the sectioning joint.
4. Create backing plates 50 mm (2 in) for the sail panel (a) and 100 mm (4 in) for the rocker panel (b). Create the backing plates from the unused portion of the service part.

5. Trim the backing plates as necessary to fit behind the panel at the sectioning joints.

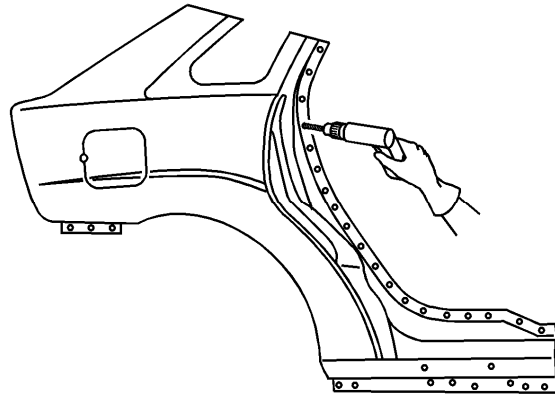

6. Drill 8 mm (5/16 in) plug weld holes as necessary in locations noted from the original quarter panel.

Important: If the location of the original plug weld holes can not be determined, or if structural weld-thru adhesive is present, space the plug weld holes every 40 mm (1 ½ in) apart.

7. Prepare all mating surfaces as necessary.
8. Apply 3M® Weld-Thru coating P/N 05916 or equivalent to all mating surfaces.
9. Perform the sectioning procedure. Refer to [Overlap/Backing Plate Sectioning](#) .

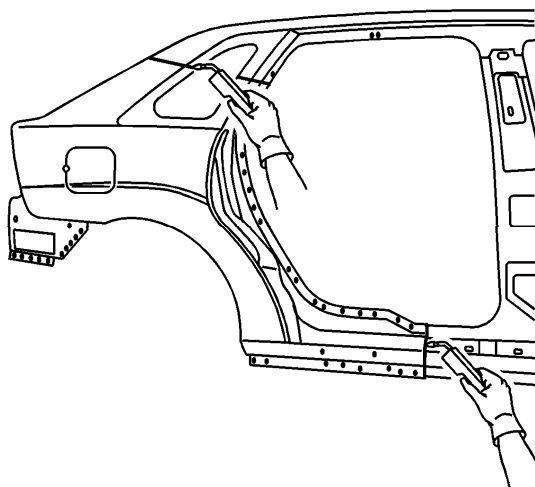

10. Plug weld accordingly.

11. Stitch weld the sail panel and rocker panel accordingly.
12. Clean and prepare all welded surfaces.
13. Apply the sealers and anti-corrosion materials to the repair area, as necessary.
Refer to [Anti-Corrosion Treatment and Repair](#) .
14. Paint the repair area. Refer to [Basecoat/Clearcoat Paint Systems](#) .
15. Install all related panels and components.
16. Enable the SIR system. Refer to [SIR Disabling and Enabling](#) .
17. Connect the negative battery cable. Refer to [Battery Negative Cable Disconnection and Connection](#) .

Installation Procedure (Adhesive Bonding)

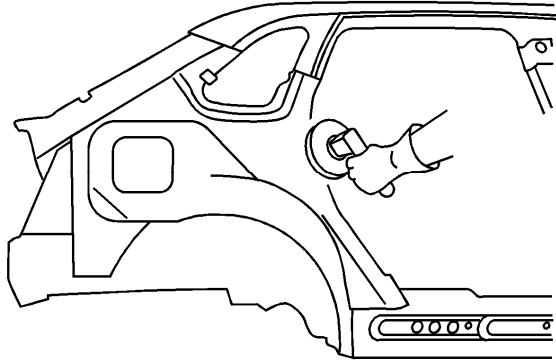

1. Grind the surface of the body mating flanges to bare steel.

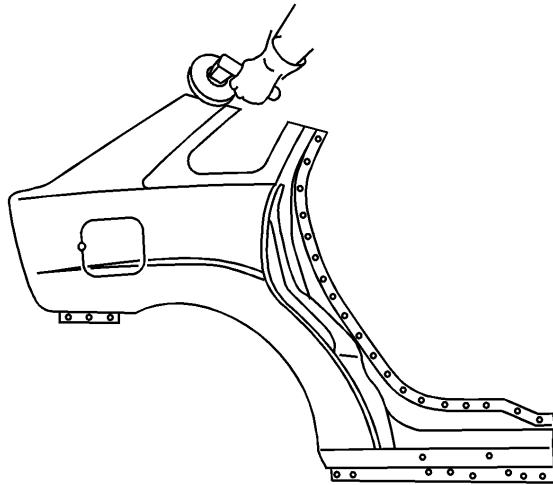

2. Grind the quarter panel mating flanges to remove the E-coating. Take care not to damage the corners or thin the metal during the grinding operation.
3. Clean the mating surfaces.

4. Perform the sectioning procedure. Refer to [Overlap/Backing Plate Sectioning](#) .

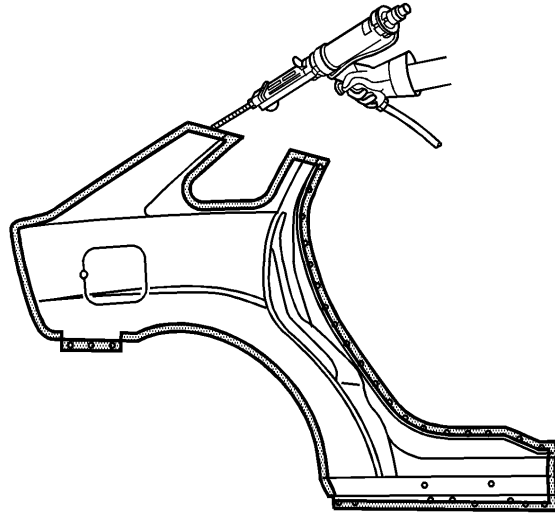

Important: The adhesive has a 40-50 minute working time. Do not allow the adhesive to totally cure off the vehicle, as proper alignment of the lower quarter panel to the body will be difficult.

5. Apply a 3-6 mm (1/8-1/4 in) bead of metal panel bonding adhesive GM P/N 12378566/7 (Canadian P/N 88901674/5) or equivalent, to both of the mating surfaces.
6. Using a small acid brush, spread a coat of adhesive to cover all the bare metal surfaces to ensure corrosion protection.

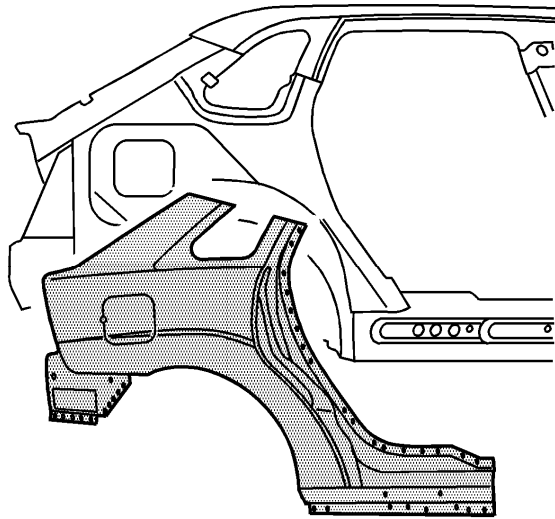

Important: DO NOT pull the panels apart after joined together. Slide the panels against each other to realign the panels.

7. Install the quarter panel to the body.

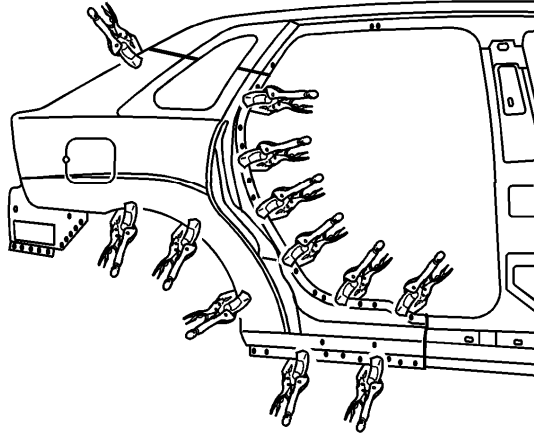

8. Clamp the quarter panel into position as required.
9. Using lacquer thinner remove the excess adhesive from the lower quarter panel area.
10. Apply the sealers and anti-corrosion materials to the repair area, as necessary. Refer to [Anti-Corrosion Treatment and Repair](#) .
11. Paint the repair area. Refer to [Basecoat/Clearcoat Paint Systems](#) .
12. Install all related panels and components.
13. Enable the SIR system. Refer to [SIR Disabling and Enabling](#) .
14. Connect the negative battery cable. Refer to [Battery Negative Cable Disconnection and Connection](#) .