

Rail Replacement Rear Side Underbody (Extended Sedan)

Removal Procedure

Caution: Refer to [Approved Equipment for Collision Repair Caution](#) in Cautions and Notices.

1. Disable the SIR system. Refer to [SIR Disabling and Enabling Zones](#) in SIR.
2. Disconnect the negative battery cable. Refer to [Battery Negative Cable Disconnect/Connect Procedure](#) in Engine Electrical.

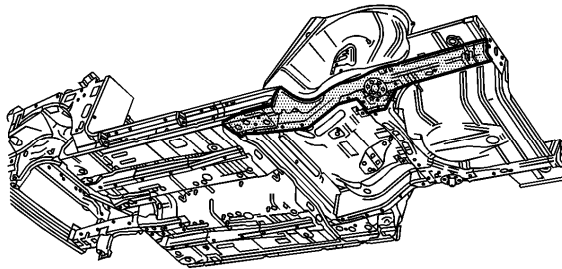

3. Remove all related panels and components.
4. Repair as much of the damaged area as possible. Refer to [Dimensions - Body](#) .
5. Remove the sealers and anti-corrosion materials from the repair area, as necessary. Refer to [Anti-Corrosion Treatment and Repair](#) in Paint and Coatings.
6. Remove the inner and outer quarter panel to access the welds from the rail to the inner rocker panel area. Refer to [Quarter Panel Sectioning - Outer](#) or to [Quarter Panel Replacement - Inner](#) .

7. Remove the filler rocker reinforcement inner panel.

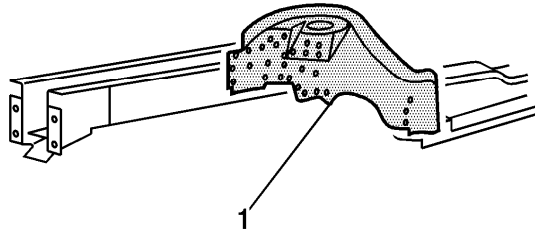

8. Remove the shock reinforcement wheel house extension (1).

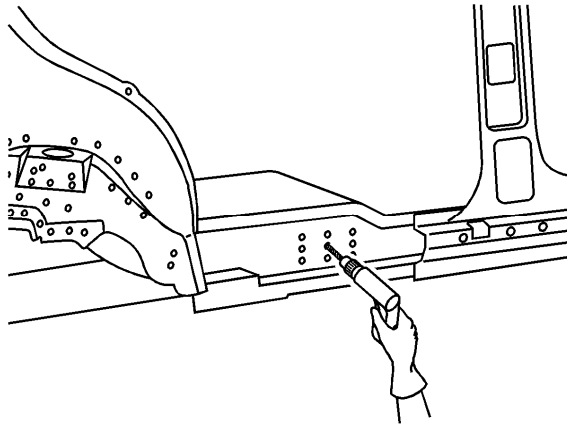

9. Locate and drill out all the necessary factory welds under the inner rocker reinforcement.

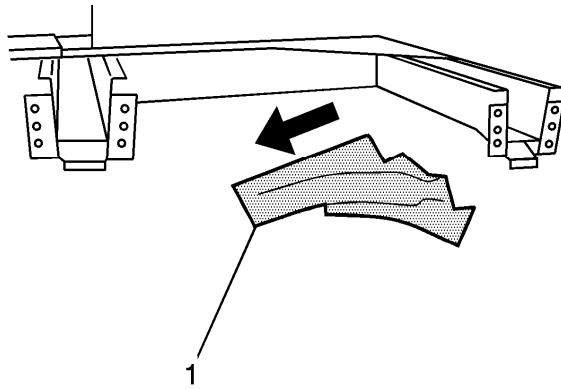

10. Locate and drill out all necessary factory welds to remove the five bar (1).

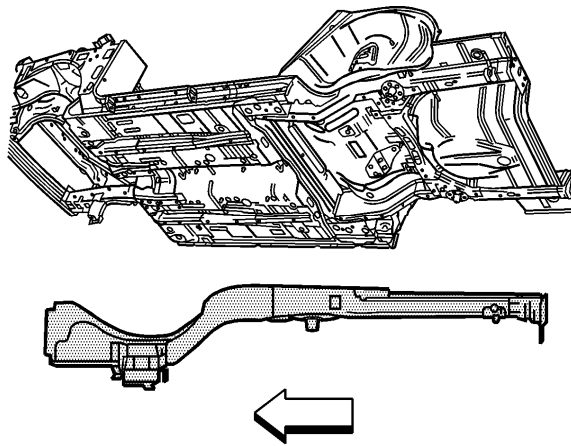

11. Remove the rear rail.

Installation Procedure

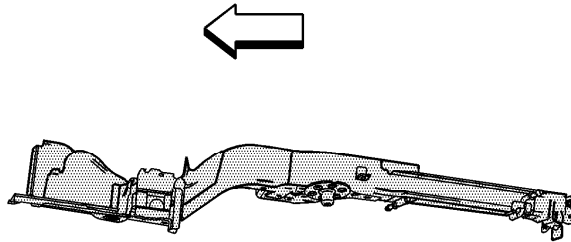

Important: If the location of the original plug weld holes can not be determined, space the plug weld holes every 40 mm (1½ in) apart.

1. Drill 8 mm (5/16 in) plug weld holes in the service part as necessary in the locations noted from the original panel.
2. Prepare all mating surfaces for welding as necessary.
3. Apply GM-approved Weld-Thru Coating or equivalent to all mating surfaces. Refer to [Anti-Corrosion Treatment and Repair](#).

Important: The service part includes a rear wheelhouse extension.

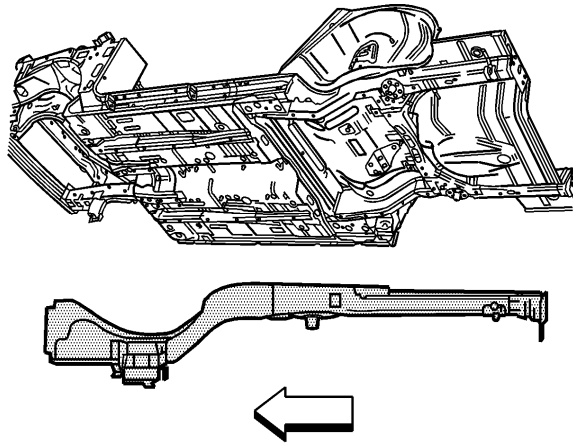

4. Position the rear rail to the vehicle using 3-dimensional measuring equipment. Clamp the rail in place.

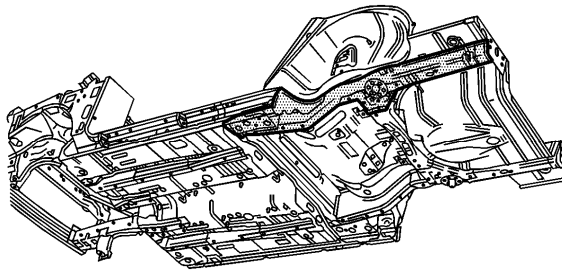

5. Plug weld accordingly.

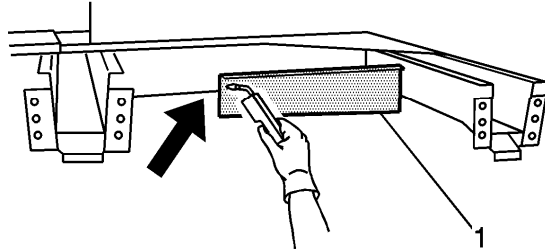

6. Install the five bar (1).

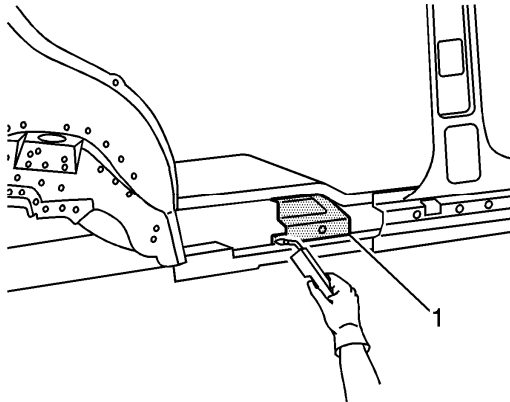

7. Install the rear rocker inner panel reinforcement (1).
8. Install the quarter panel.
9. Install the inner panel.
10. Install all of the related panels and components.
11. Apply the sealers and anti-corrosion materials to the repair area, as necessary. Refer to [Anti-Corrosion Treatment and Repair](#) in Paint and Coatings.
12. Paint the repaired area. Refer to [Basecoat/Clearcoat Paint Systems](#) in Paint and Coatings.
13. Connect the negative battery cable. Refer to [Battery Negative Cable Disconnect/Connect Procedure](#) in Engine Electrical.
14. Enable the SIR system. Refer to [SIR Disabling and Enabling Zones](#) in SIR.