

Rail Sectioning Rear Side Underbody (3/4 Rail)

Removal Procedure

Caution: Refer to [Approved Equipment for Collision Repair Caution](#) in Cautions and Notices.

1. Disable the SIR system. Refer to [SIR Disabling and Enabling Zones](#) in SIR.
2. Disconnect the negative battery cable. Refer to [Battery Negative Cable Disconnect/Connect Procedure](#) in Engine Electrical.

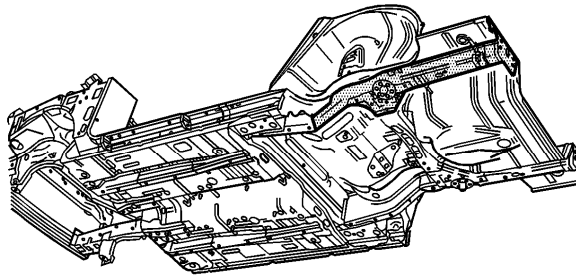

3. Remove all related panels and components.
4. Repair as much of the damaged area as possible. Refer to [Dimensions - Body](#) .
5. Remove the sealers and anti-corrosion materials from the repair area, as necessary. Refer to [Anti-Corrosion Treatment and Repair](#) in Paint and Coatings.

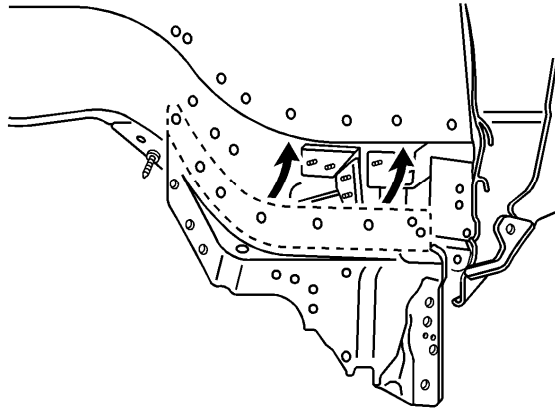

Important: There is a hidden weld under the wheelhouse.

6. Remove the rear wheelhouse extension.

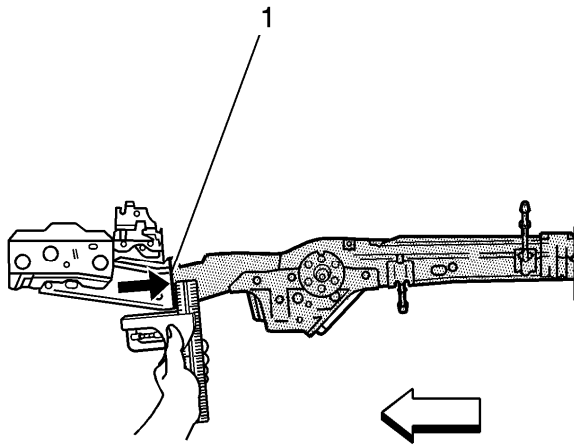

7. Measure from the rear edge of the control arm attaching hole rearward 30 mm (1.2 in) (1). Align a sliding square or similar tool to the measured point. Scribe a line across the rail at the measured point.

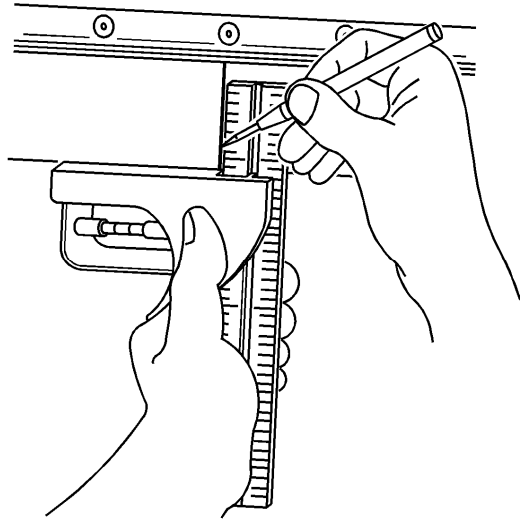

8. Use a sliding square to transfer the scribed line onto the sides and weld flanges of the rail.

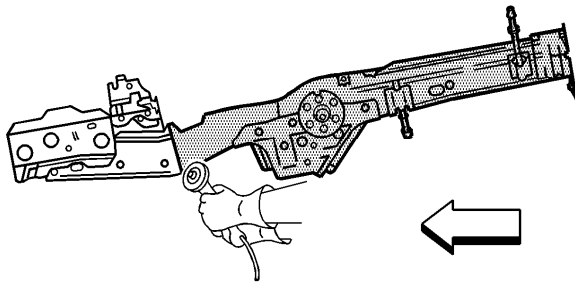

9. Cut the rail at the marked location.

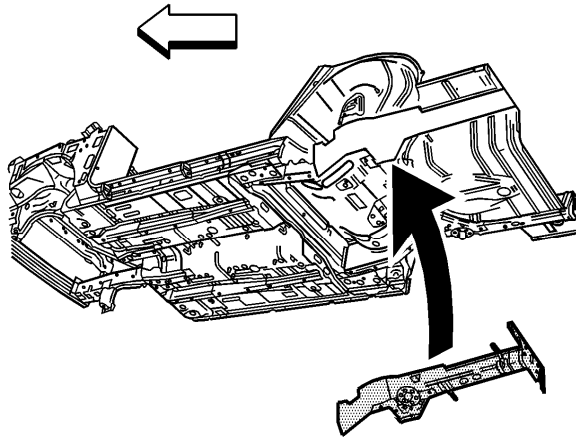

10. Remove the damaged rail from the vehicle.

Installation Procedure

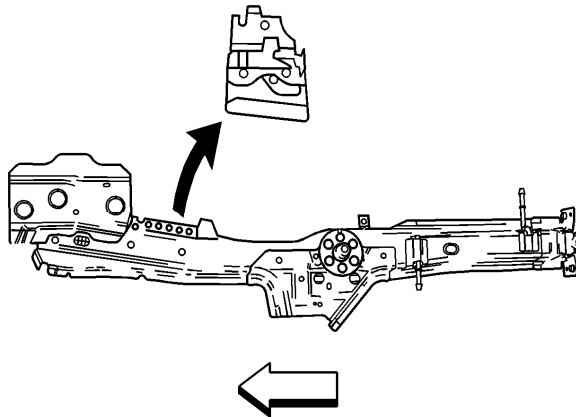

Important: The service part includes the rear wheelhouse extension and the filler rocker inner panel bracket for the rear axle control arm. You may not section the rear rail with the rear wheelhouse extension and the bracket for the rear axle control arm.

1. Remove the rear wheelhouse extension.
2. Remove the bracket for the rear axle control arm.
3. Drill out the spot welds.

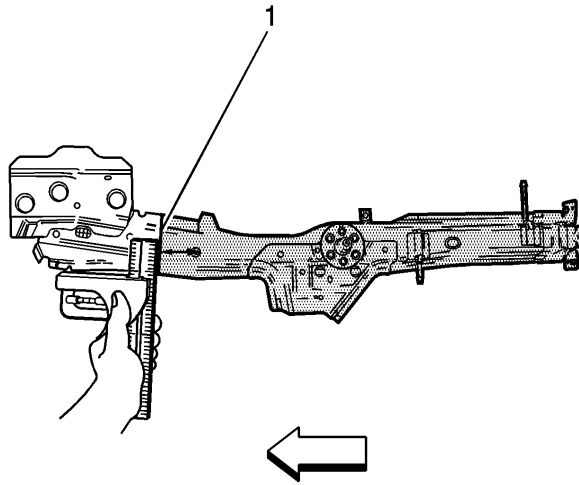

4. Measure from the rear edge of the control arm attaching hole forward (1) 90 mm (3.5 in) on the service part rear rail. Align a sliding square or similar tool to the measured point. Scribe a line across the rail at the measured point.

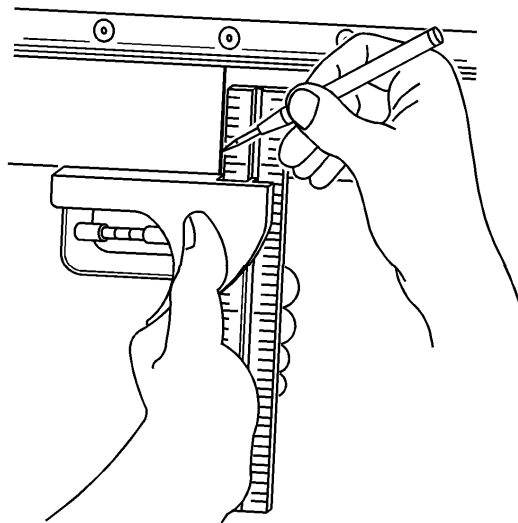

5. Use a sliding square to transfer the scribed line onto the sides and weld flanges of the rail.

6. Cut the rail at the scribed line.

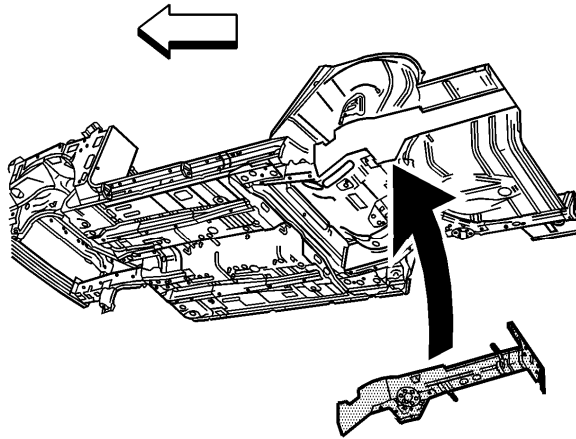

7. Remove the rear rail.

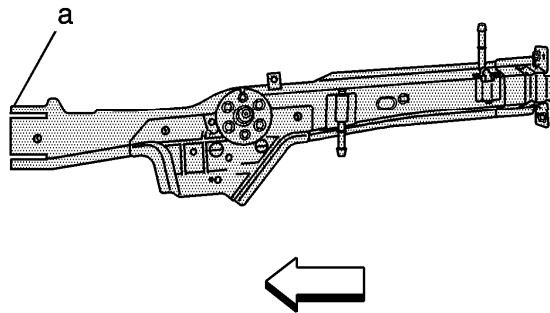

8. Measure from the cut edge of the service rail (a) 110 mm (4.3 in) toward the rear of the vehicle. Cut a slot in the upper outer edges of the service rail.

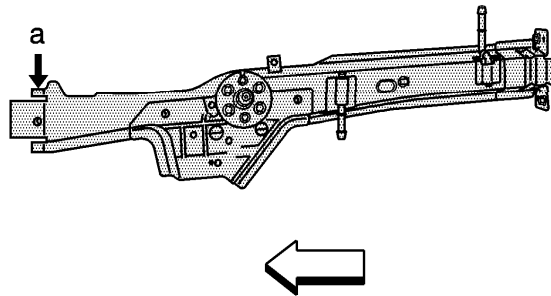

9. Measure from the cut edges of the rail (a) 70 mm (2.75 in). Cut the upper outer flanges of the rear rail service part. Remove the tabs.

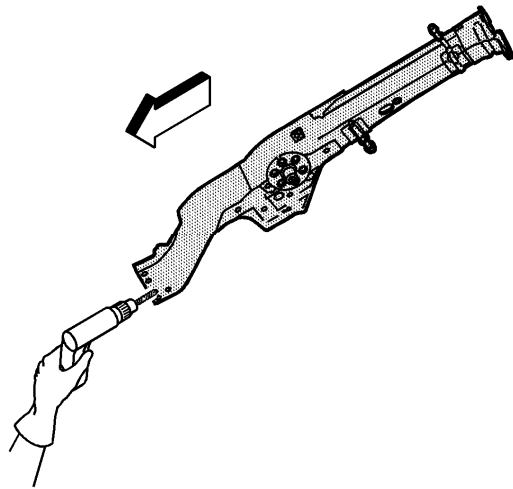

10. Drill two 8 mm (5/16 in) plug weld holes on each of the 3 sides of the rear rail. Position the center of the holes 10 mm (3/8 in) from the cut edge.
11. Prepare all mating surfaces for welding as necessary.
12. Apply GM-approved Weld-Thru Coating or equivalent to all mating surfaces. Refer to [Anti-Corrosion Treatment and Repair](#).

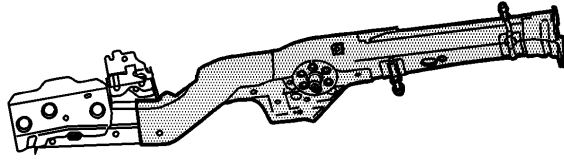

13. Position the rear rail section using 3-dimensional measuring equipment. The service rail will overlap the existing rail in the vehicle. Clamp the rail section in place.

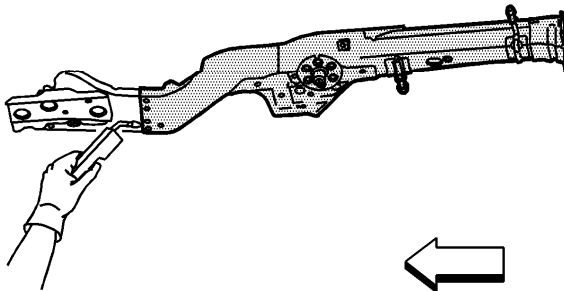

14. Tack weld the part into position.
15. Inspect the service rear rail for proper dimensions, using 3-dimensional measuring equipment.
16. Plug weld accordingly at each plug weld hole location.
17. Stitch weld along the entire sectioning joint. Make the welds along the seam with 25 mm (1 in) gaps between. Weld the gaps.

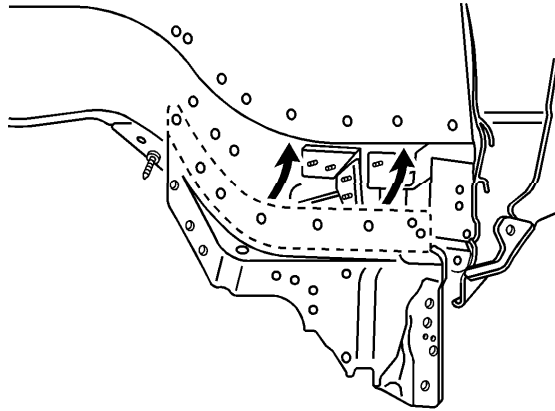

18. Install the rear wheelhouse extension.
19. Clean and prepare all of the welded surfaces.
20. Install all of the related panels and components.
21. Apply the sealers and anti-corrosion materials to the repair area, as necessary.
Refer to [Anti-Corrosion Treatment and Repair](#) in Paint and Coatings.
22. Paint the repaired area. Refer to [Basecoat/Clearcoat Paint Systems](#) in Paint and Coatings.
23. Enable the SIR system. Refer to [SIR Disabling and Enabling Zones](#) in SIR.
24. Connect the negative battery cable. Refer to [Battery Negative Cable Disconnect/Connect Procedure](#) in Engine Electrical.