

Lower Rail Replacement

Removal Procedure

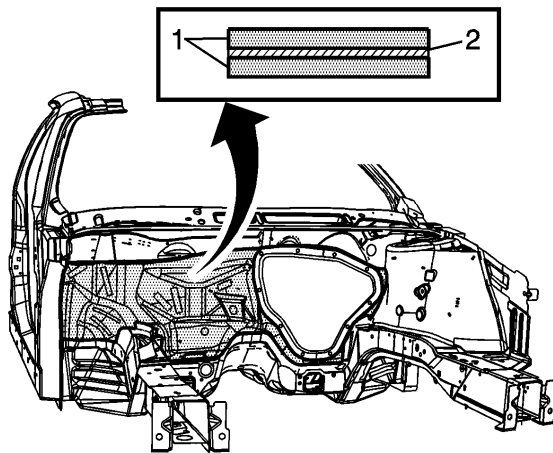

Caution: Refer to [Approved Equipment for Collision Repair Caution](#) in Cautions and Notices.

Caution: Refer to [Foam Sound Deadeners Caution](#) in Cautions and Notices.

Important:

- Model year 2004 and prior vehicles are not manufactured with laminated steel in front of the dashes. Therefore, the front lower rail can be metal inert gas (MIG) welded instead of the rivet and bonding process, as stated in these instructions.
- Failure to follow this procedure will compromise the structural integrity of the vehicle.

The front of the dash panel is formed from laminated steel. This steel is constructed by bonding 2 pieces of cold rolled steel (1) with a viscoelastic layer of adhesive (2). MIG welding laminated steel does not meet GM Corporate standards for structural integrity. As an alternative, all factory welds will be replaced by using the rivet and adhesive bond method described in the installation portion of this procedure. The

rivet and adhesive bond method must only be used in the areas as described in this procedure.

1. Disable the SIR system. Refer to [SIR Disabling and Enabling](#) in SIR.
2. Disconnect the negative battery cable. Refer to [Battery Negative Cable Disconnection and Connection](#) in Engine Electrical.

Caution: Refer to [Collision Sectioning Caution](#) in Cautions and Notices.

3. Remove all related panels and components.
4. Repair as much of the damage as possible.
5. Remove the sealers and the anti-corrosion materials from the repair area, as necessary. Refer to [Anti-Corrosion Treatment and Repair](#) in Paint/Coatings.

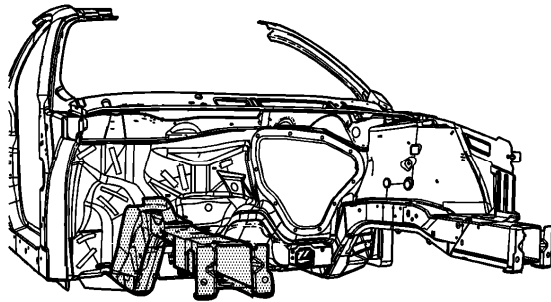

Important: Note the number and location of the factory welds for installation of the full rail service part.

6. Remove the front wheelhouse assembly. Refer to [Front Wheelhouse Replacement](#) .
7. Remove the radiator support assembly. Refer to [Upper Rail Replacement](#) .
8. Remove the front rail side extension. Refer to [Front Compartment Side Rail Rear Extension Replacement](#) .

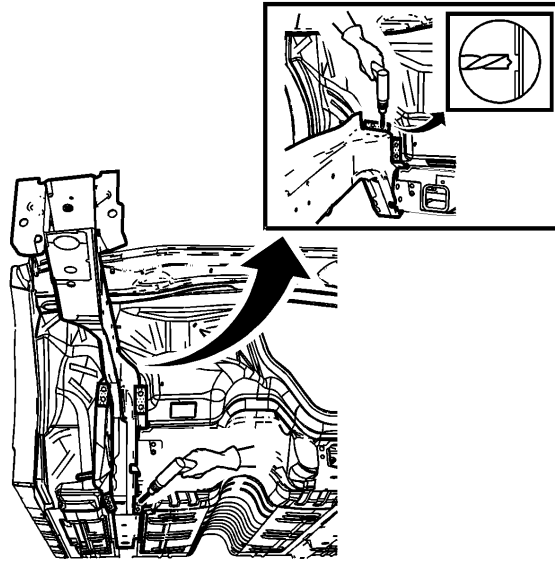

Important: Drill through the rail flange only. Do NOT drill into the dash panel or the inner reinforcements.

9. Using an 8-mm (5/16-in) spot weld remover, locate and drill out the factory welds on the weld flange connecting the lower rail to the dash panel.

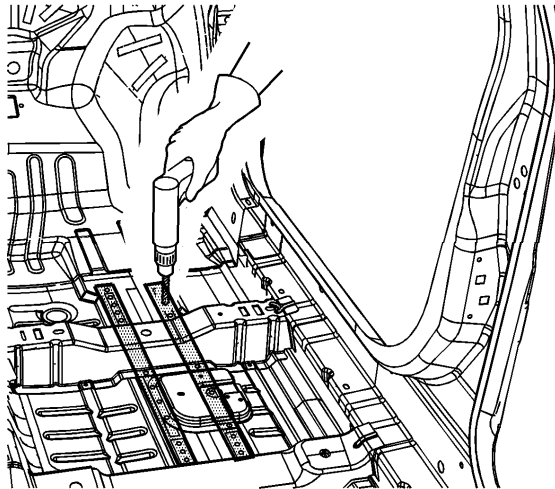

10. From the passenger compartment, locate and drill out the remaining factory weld.

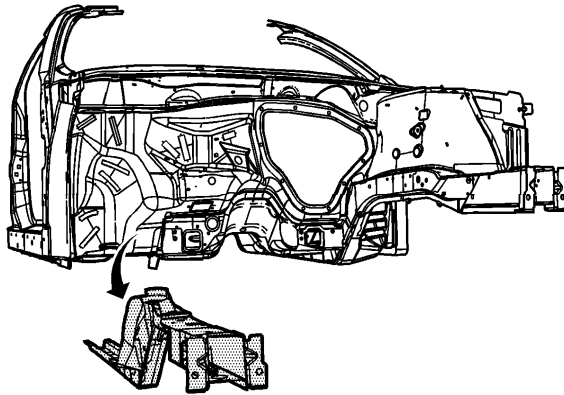

11. Remove the full rail.

Installation Procedure

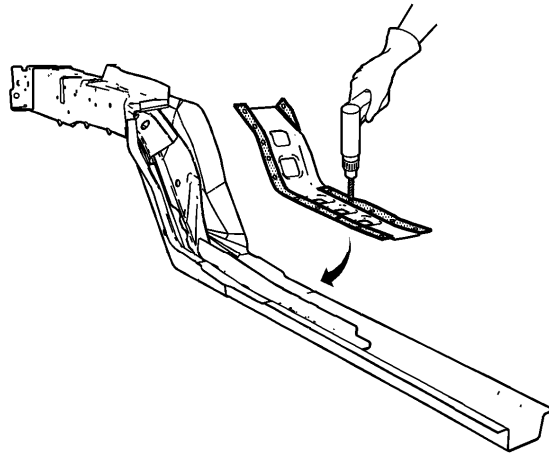

Important: Failure to install the front compartment lower rail reinforcement to the front compartment lower rail will compromise the structural integrity of the vehicle.

1. Drill 8-mm (5/16-in) plug weld holes in the service front lower rail reinforcement in the location noted from the original rail.
2. Prepare the plug weld mating surfaces, as necessary.
3. Apply GM-approved Weld-Thru Coating or equivalent to all mating surfaces.
Refer to [Anti-Corrosion Treatment and Repair](#).
4. Position the front lower rail reinforcement.

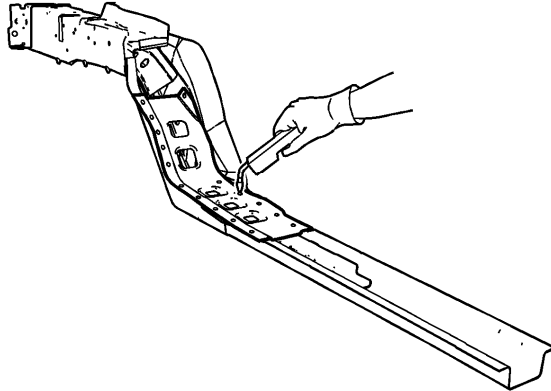

5. Plug weld the holes accordingly.

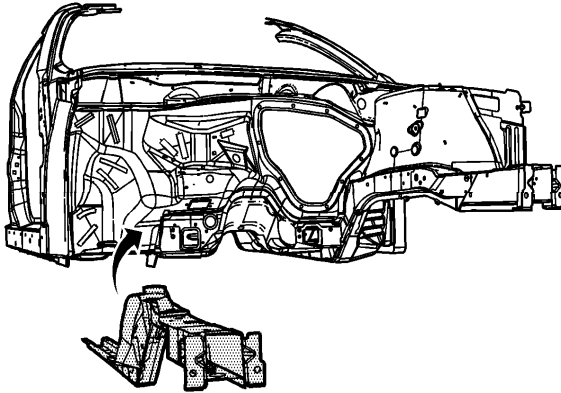

6. Position the service rail to the vehicle using 3-dimensional measuring equipment.

7. Clamp the rail in place.

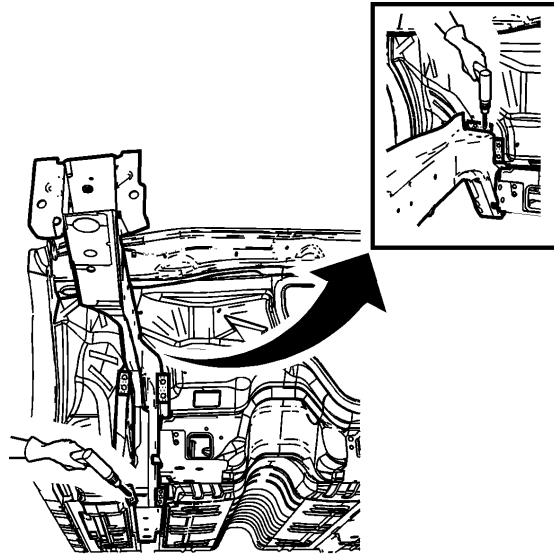

8. Using a 7-mm (17/64-in) bit, drill the rivet attachment holes through the service rail and the dash panel in the exact locations, as noted from the factory rail.

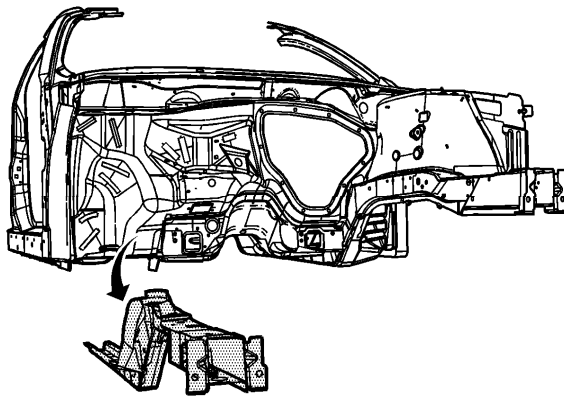

Important: If the location of the original plug weld holes cannot be determined, space the plug weld holes every 40 mm (1.5 in) apart.

9. Remove the service rail.
10. Prepare the plug weld mating surfaces, as necessary.
11. Apply 3M® Weld-Thru Coating P/N 05913 or equivalent to the plug weld mating surfaces.

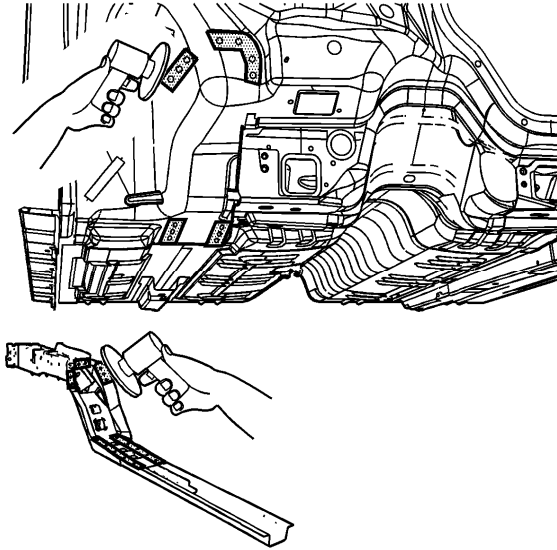

12. Prepare the bond mating areas by grinding the body mating and the service part flanges to bare steel. Do NOT damage the corners or thin the metal during the grinding process.

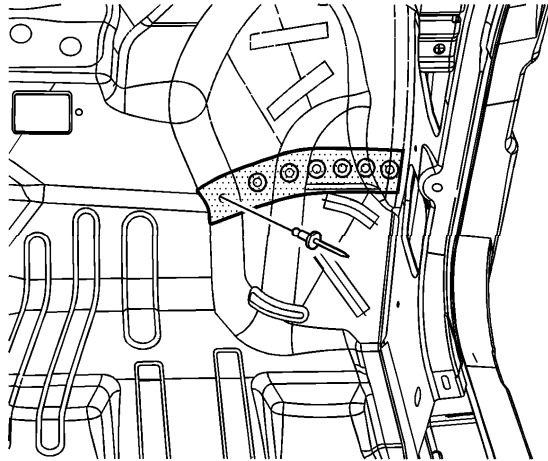

Important:

- Do NOT allow the adhesive to cure prior to installation of the front rail side extension. Refer to [Front Compartment Side Rail Rear Extension Replacement](#)
- Note the necessary location for installation of a 14-mm (17/32-in) long rivet.

13. Clean the mating surfaces.

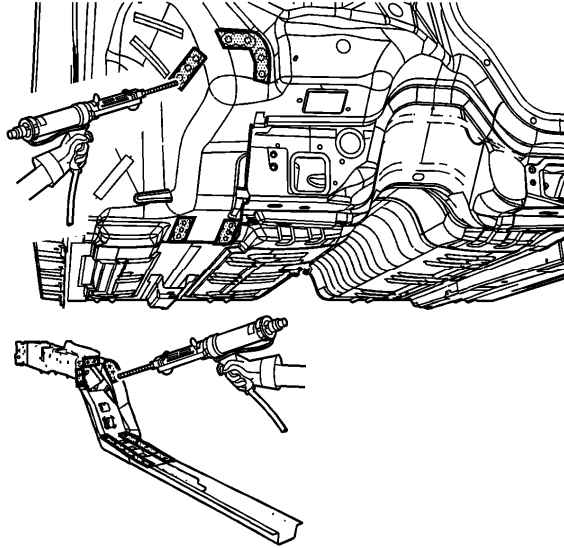

Important: The adhesive has a 40-50 minute working time. Do NOT allow the adhesive to cure prior to installing the service rail.

14. Apply a 3-6 mm (1/8 to 1/4 in) bead of metal panel bonding adhesive GM P/N 12378567 (Canadian P/N 88901675) or equivalent to both of the mating surfaces.

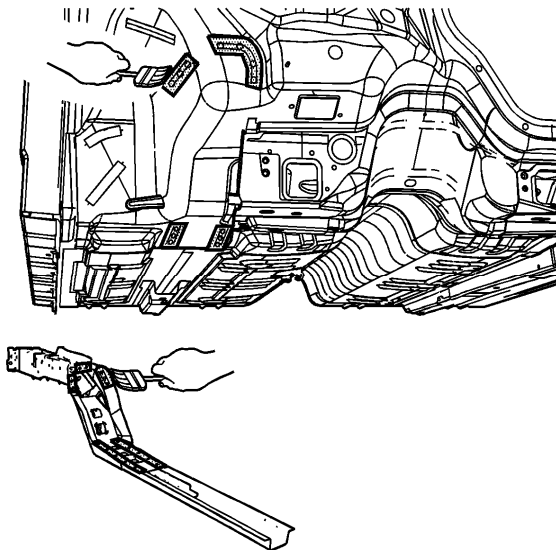

15. Using a small acid brush, spread a coat of adhesive to both of the mating surfaces. Cover all of the bare metal to ensure corrosion protection.

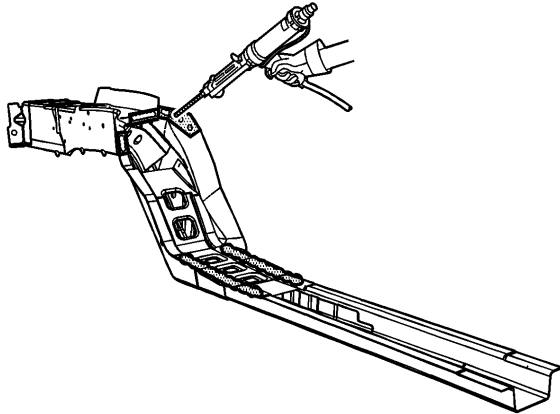

16. Apply a 3-6 mm (1/8 to 1/4 in) bead of metal panel bonding adhesive GM P/N 12378567 (Canadian P/N 88901675) or equivalent to the mating surface of the service rail.

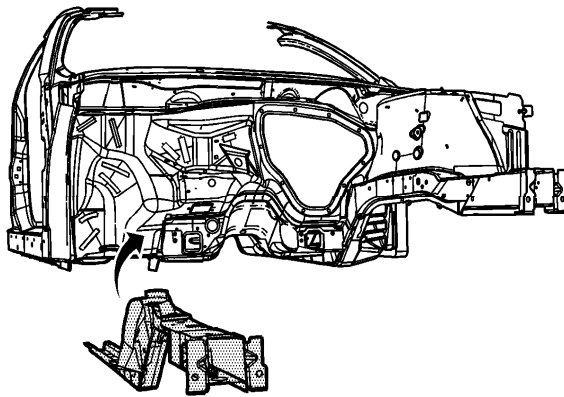

Important: Do NOT pull the rail off of the dash after adhesion. To align the parts, slide the rail against the front of the dash.

17. Position the service rail to the vehicle using 3-dimensional measuring equipment.

18. Clamp the rail in place.

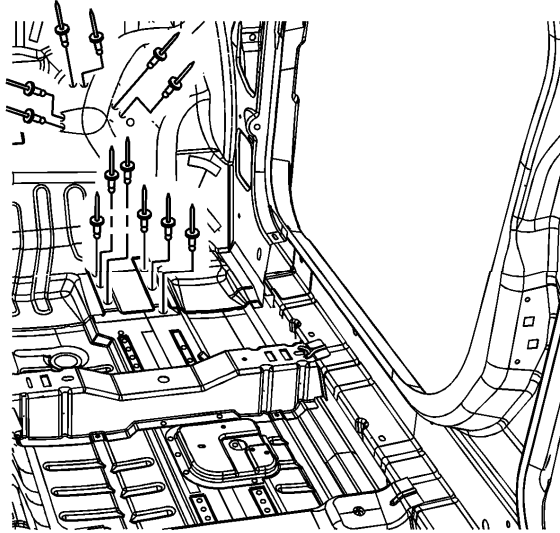

Important: Verify proper positioning of the service rail prior to riveting and welding.

19. Install the 9-mm (11/32-in) long rivets, so that the rivet head contacts the passenger compartment side of the dash.

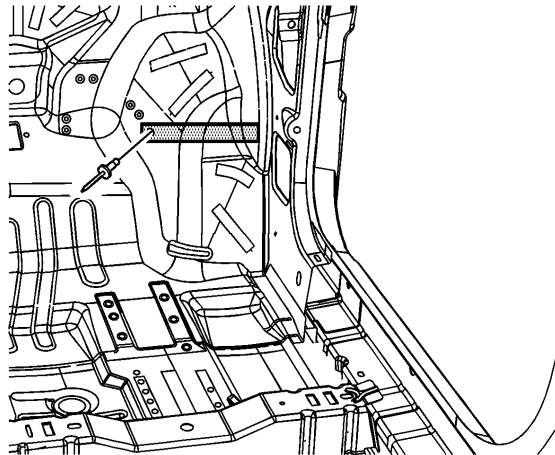

20. Install the 14-mm (17/32-in) long rivet, so that the rivet head contacts the passenger compartment side of the dash, extending through the front rail and through the rail side extension.

21. Remove the excess adhesive from the rail area.

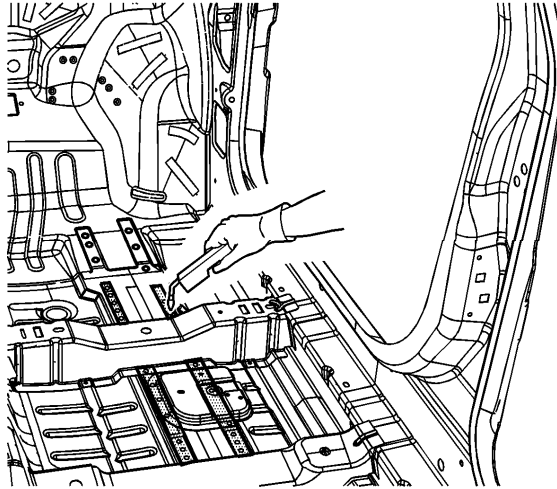

22. Plug weld the remaining holes, accordingly.
23. Clean and prepare all of the welded surfaces.
24. Install the front wheelhouse assembly. Refer to [Front Wheelhouse Replacement](#) .
25. Install the front rail side extension. Refer to [Front Compartment Side Rail Rear Extension Replacement](#) .
26. Install the radiator support assembly. Refer to [Upper Rail Replacement](#) .
27. Apply the sealers and anti-corrosion materials to the repaired area, as necessary. Refer to [Anti-Corrosion Treatment and Repair](#) in Paint/Coatings.
28. Paint the repaired area. Refer to [Basecoat/Clearcoat Paint Systems](#) in Paint/Coatings.
29. Install all of the related panels and components.
30. Connect the negative battery cable. Refer to [Battery Negative Cable Disconnection and Connection](#) in Engine Electrical.
31. Enable the SIR system. Refer to [SIR Disabling and Enabling](#) in SIR.